

01 PROPOSED CORNICE PROFILE - COV1

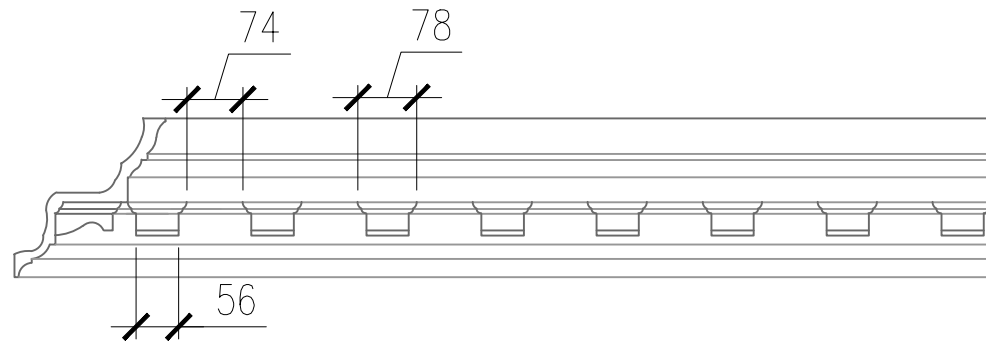

01 PROPOSED CORNICE ELEVATION - COV1
GROUND FLOOR
ENTRANCE LOBBY
FIRST FLOOR
STAIR LANDING

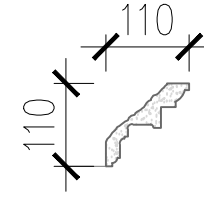

04 PROPOSED CORNICE PROFILE - COV4

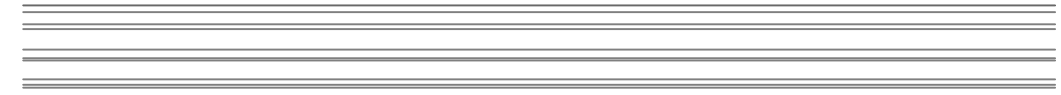

04 PROPOSED CORNICE ELEVATION - COV4
GROUND FLOOR
WC
SECOND FLOOR
MASTER BEDROOM
MASTER EN-SUITE
BOTH DRESSING ROOMS

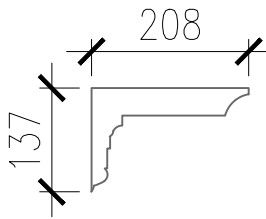

02 PROPOSED CORNICE PROFILE - COV2

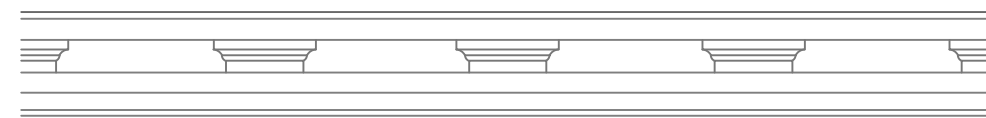

02 PROPOSED CORNICE ELEVATION - COV2
GROUND FLOOR
LIVING/DINING ROOM/KITCHEN

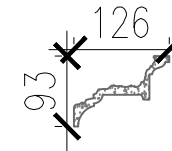

05 PROPOSED CORNICE PROFILE - COV5



05 PROPOSED CORNICE ELEVATION - COV5
THIRD FLOOR
THROUGHOUT THIRD FLOOR

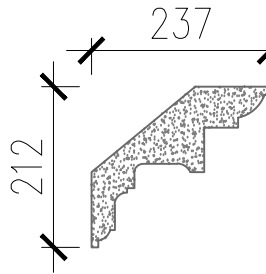

03 PROPOSED CORNICE PROFILE - COV3

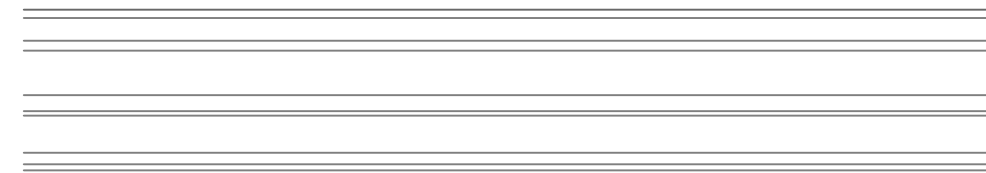

03 PROPOSED CORNICE ELEVATION - COV3
LOWER GROUND FLOOR
THROUGHOUT LOWER GROUND FLOOR

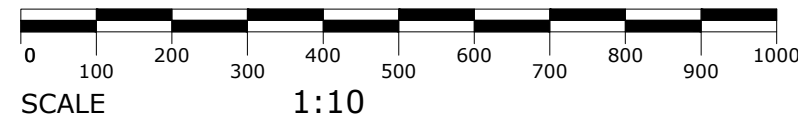

Planning & LBC

Rev	Notes	Date	By

Date	Scale	Drawn
Oct 22	1:10@A3	CS
drwg. no		Rev.
GHV-431		-