

Section through horizontal part

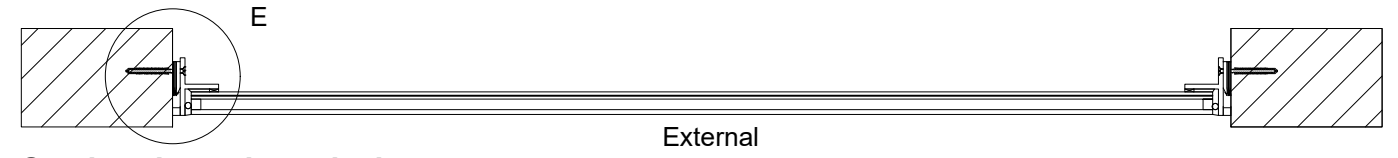

Section through vertical part

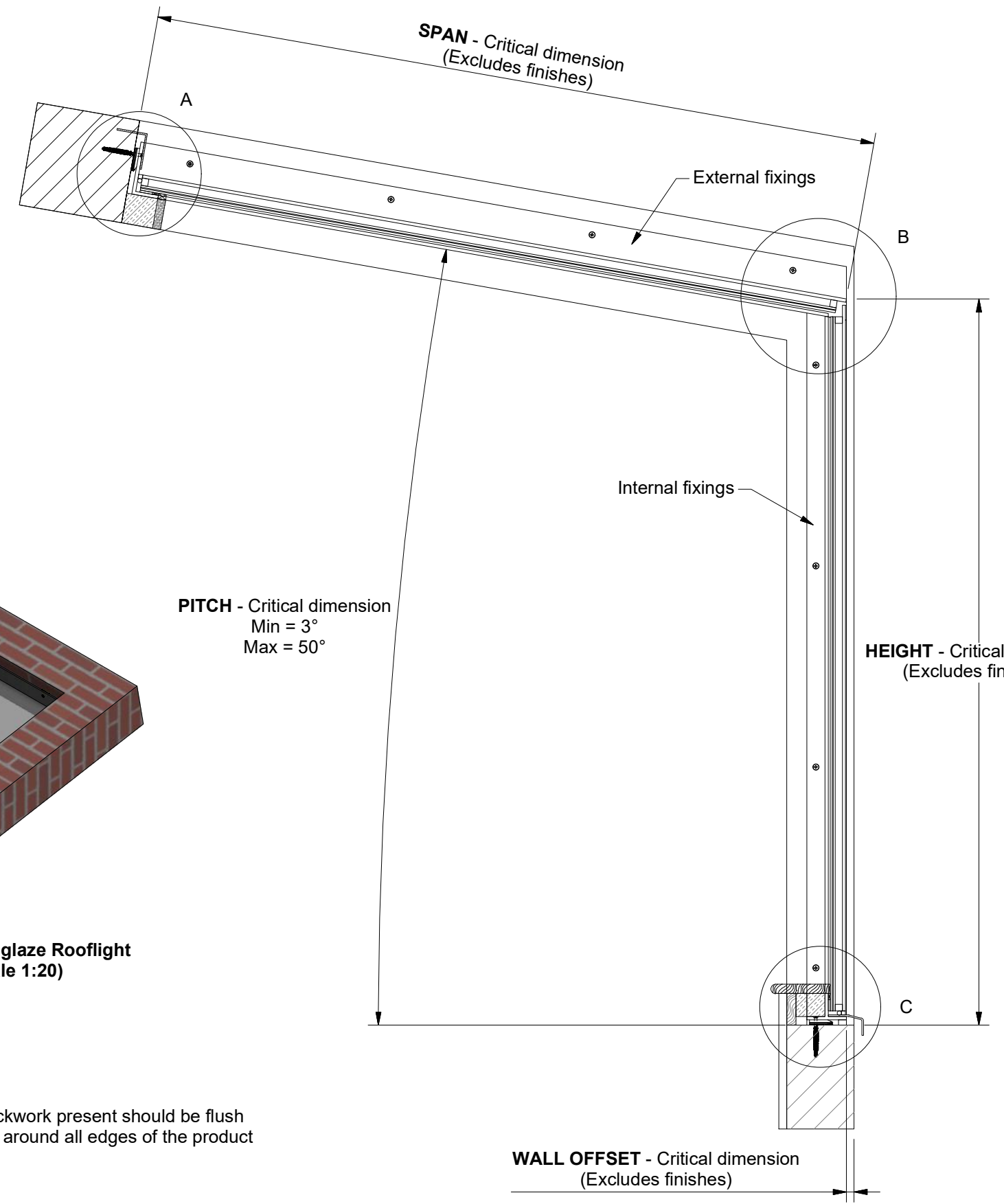
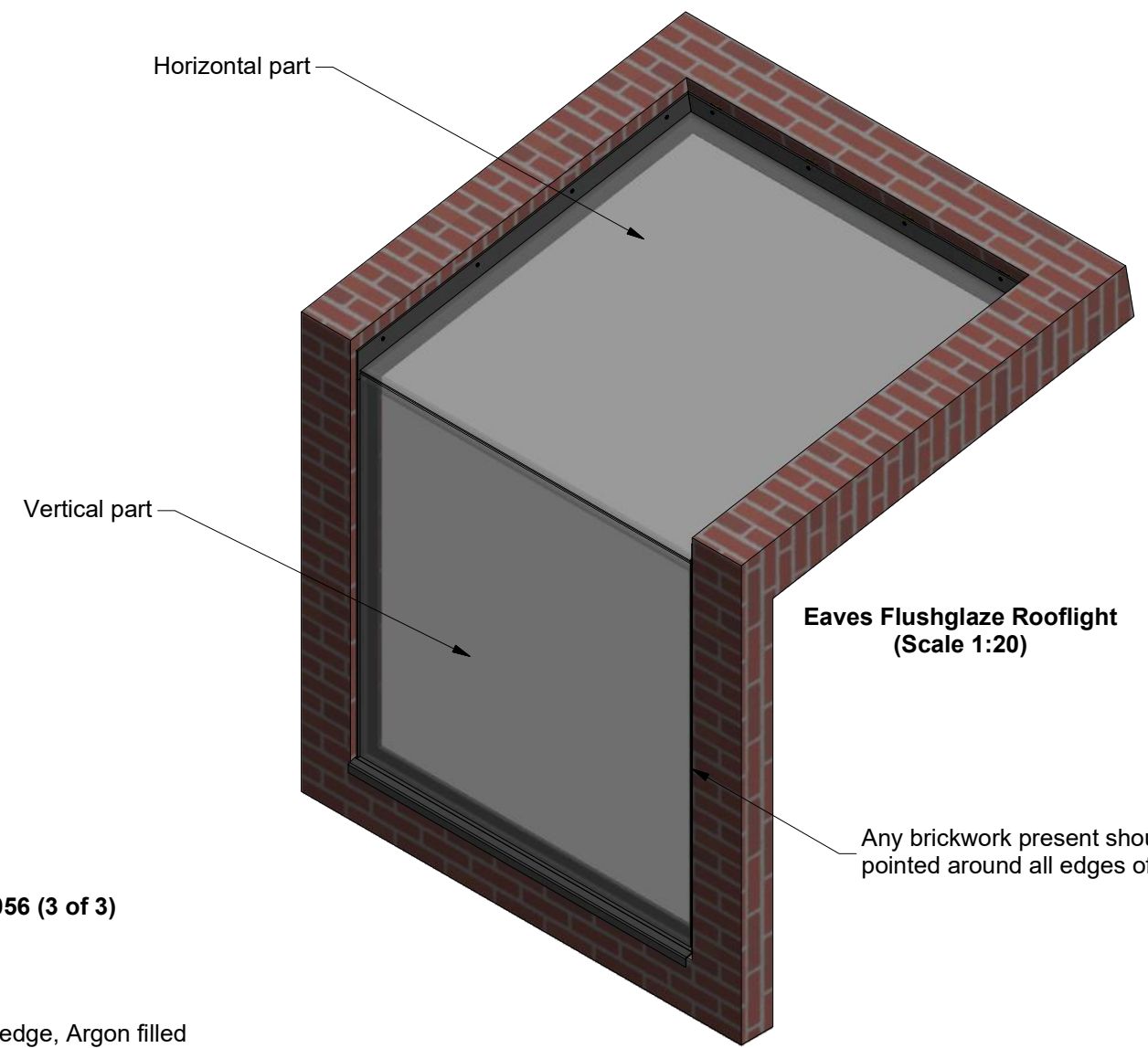

For detail views refer to drawings:
402-ASS-056 (2 of 3) and 402-ASS-056 (3 of 3)

Standard Glass Specification:

Outer: 6mm Clear HST Toughened
Spacer: 14mm Black, Silicone, Warm edge, Argon filled
Inner: 9.5mm Clear Soft Low E Heat Strengthened Laminated

GLAZING VISION
Saw Mills Road
Diss
Norfolk
IP22 4RG
Tel: +44 (0)333 8000 881
Fax: +44 (0)333 8000 882
Email: sales@glazingvision.co.uk
Website: www.glazingvision.co.uk

IT IS GLAZING VISION'S POLICY TO CONTINUOUSLY DEVELOP AND IMPROVE OUR PRODUCTS. WE THEREFORE RESERVE THE RIGHT TO MODIFY OR CHANGE THE DETAIL DESIGN AT OUR DISCRETION AND WITHOUT PRIOR NOTICE. THIS DRAWING IS COPYRIGHT AND THE SOLE PROPERTY OF GLAZING VISION LTD. THE DESIGNS/INFORMATION IT CONTAINS ARE PRIVATE AND CONFIDENTIAL. IT MUST NOT BE COPIED, EXHIBITED OR COMMUNICATED TO THIRD PARTIES FOR ANY PURPOSE OTHER THAN THAT FOR WHICH IT WAS ISSUED WITHOUT THE WRITTEN PERMISSION OF GLAZING VISION LTD.

Third angle projection unless otherwise noted.
Tolerances:
Whole numbers = ±1mm
One decimal place = ±0.5mm
Two decimal places = ±0.2mm
All angles 90±0.5 degrees unless specified
IF IN DOUBT - ASK! DO NOT SCALE
Supplier to deburr & remove sharp corners

Rev	Revision Description	Drawn/Date
H	Added note about Black obscured glass region	HTT 05.02.20
I	Corrected span dimension	HL 26.05.20

Product: 402 - GV Standard Eaves Flushglaze	Checked By: JSL
Description: Eaves Flushglaze	Check Date: 26.05.20
Materials: N/A	Drawn By: JWJ
Finish: N/A	Drawn Date: 25.01.17
Weight: 373.585 kg	Quantity: N/A
Quantity: N/A	Scale: 1:25 & 1:10
Drawing No: 402-ASS-056 (1 of 3)	

Detail A (Scale 1:2)

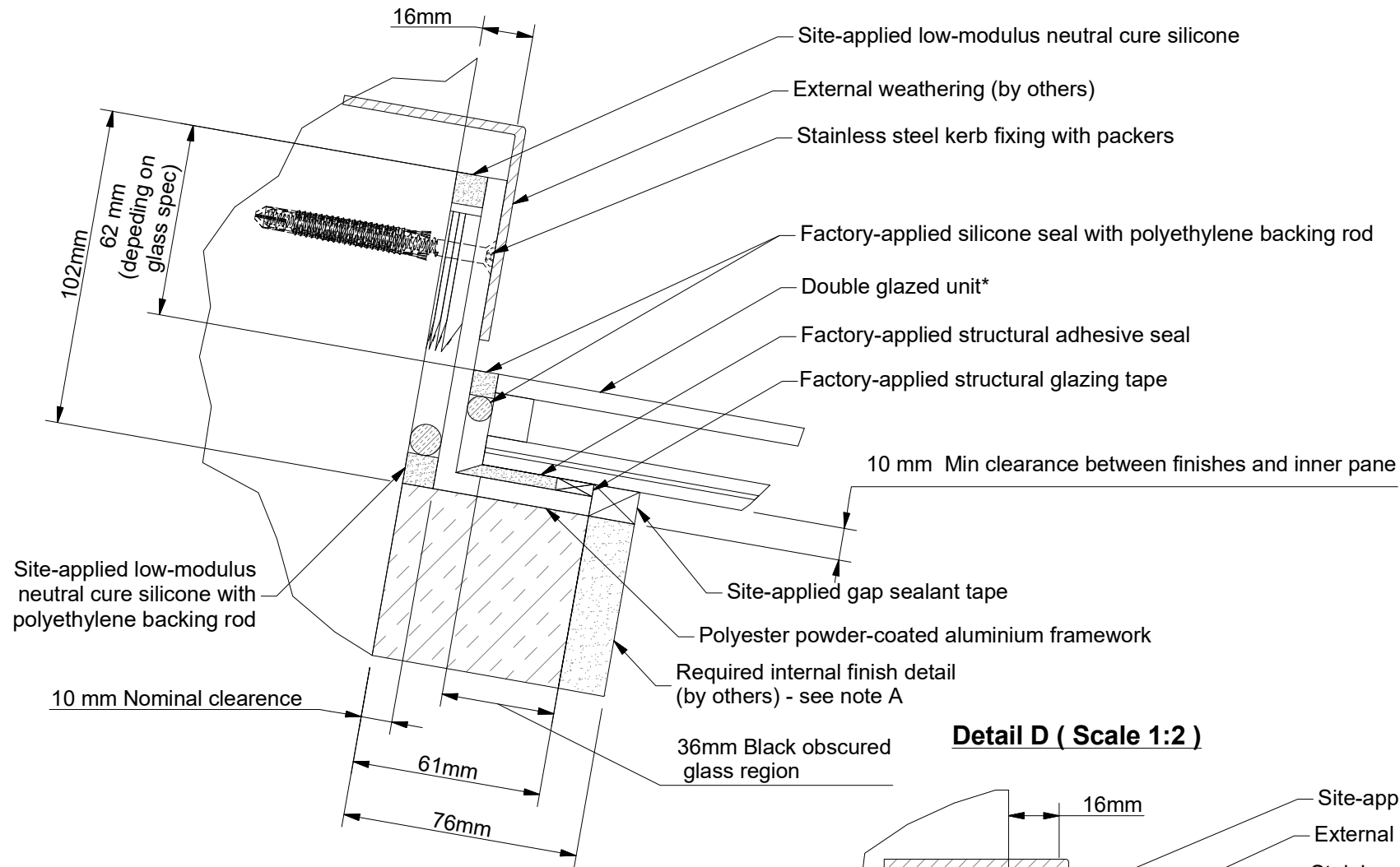

Detail B (Scale 1 : 2)
Glass to glass joint

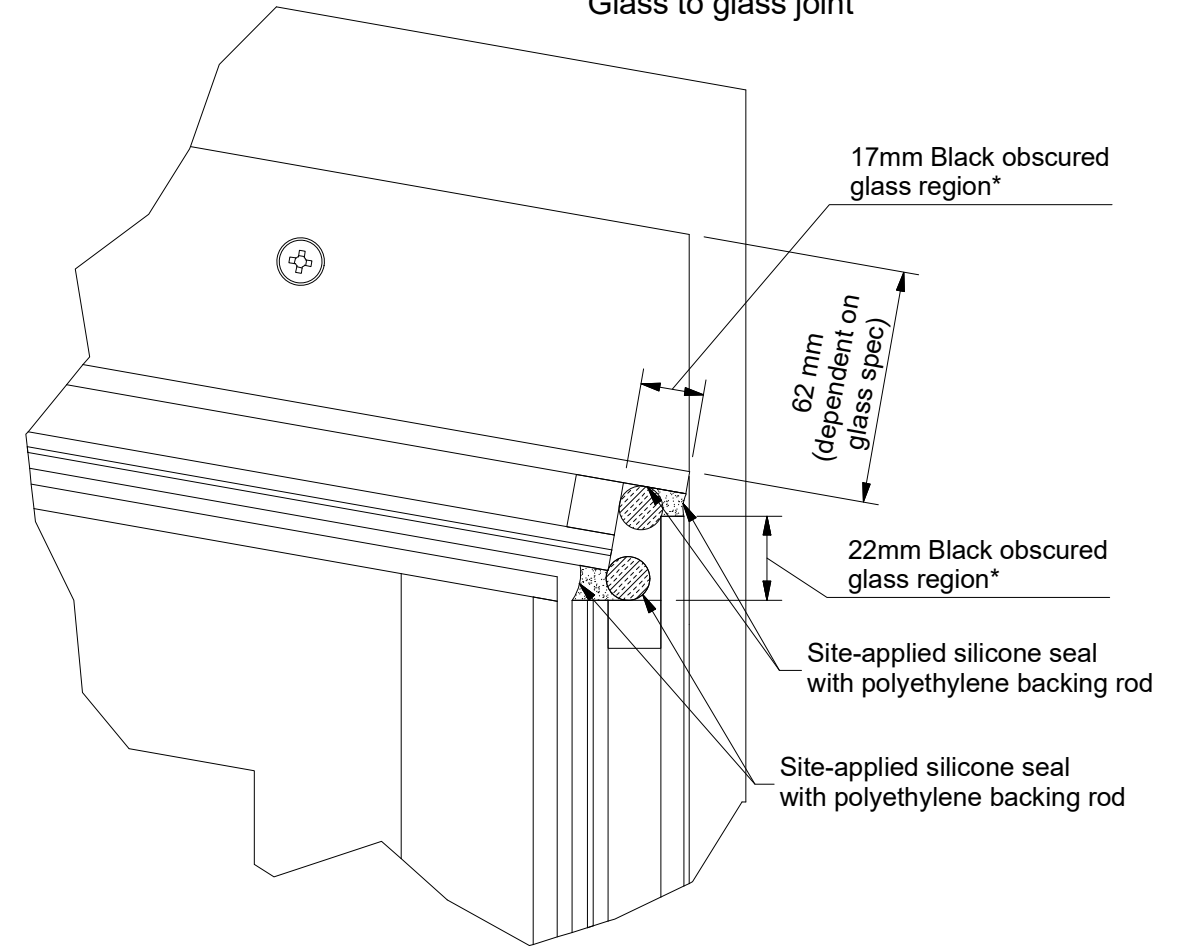

Detail D (Scale 1:2)

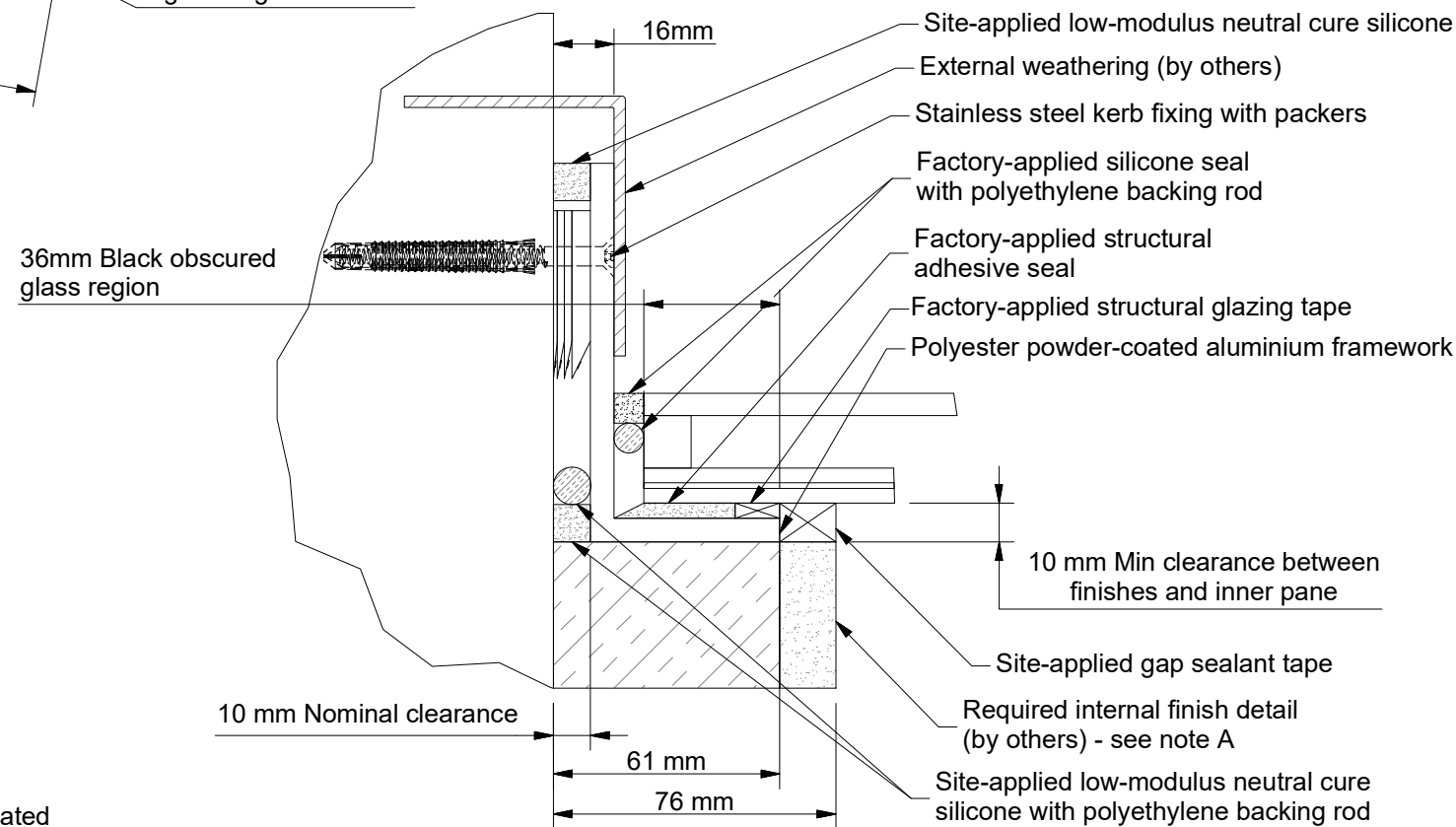

For cross-section locations refer to drawing: 402-ASS-056 (1 of 3)

Standard Glass Specification:

Outer: 6mm Clear HST Toughened
 Spacer: 14mm Black, Silicone, Warm edge, Argon filled
 Inner: 9.5mm Clear Soft Low E Heat Strengthened Laminated

* Varies depending on glass specification.

Note A:
 Internal finishes supported on battens with an insulated gap to mask exposed wall mount detail. To be constructed (by others) after rooflight installation.

Rev	Revision Description	Drawn/Date
H	Added note about Black obscured glass region	HTT 05.02.20
I	Corrected span dimension	HL 26.05.20

Product: 402 - GV Standard Eaves Flushglaze	Checked By: JSL
Description: Eaves Flushglaze	
Materials: N/A	Check Date: 26.05.20
Finish: N/A	Drawn By: JWJ
Weight: 373.585 kg	Drawn Date: 25.01.17
Quantity: N/A	Drawing No: 402-ASS-056 (2 of 3)
Scale: 1:2	

Detail C (Scale 1:2)

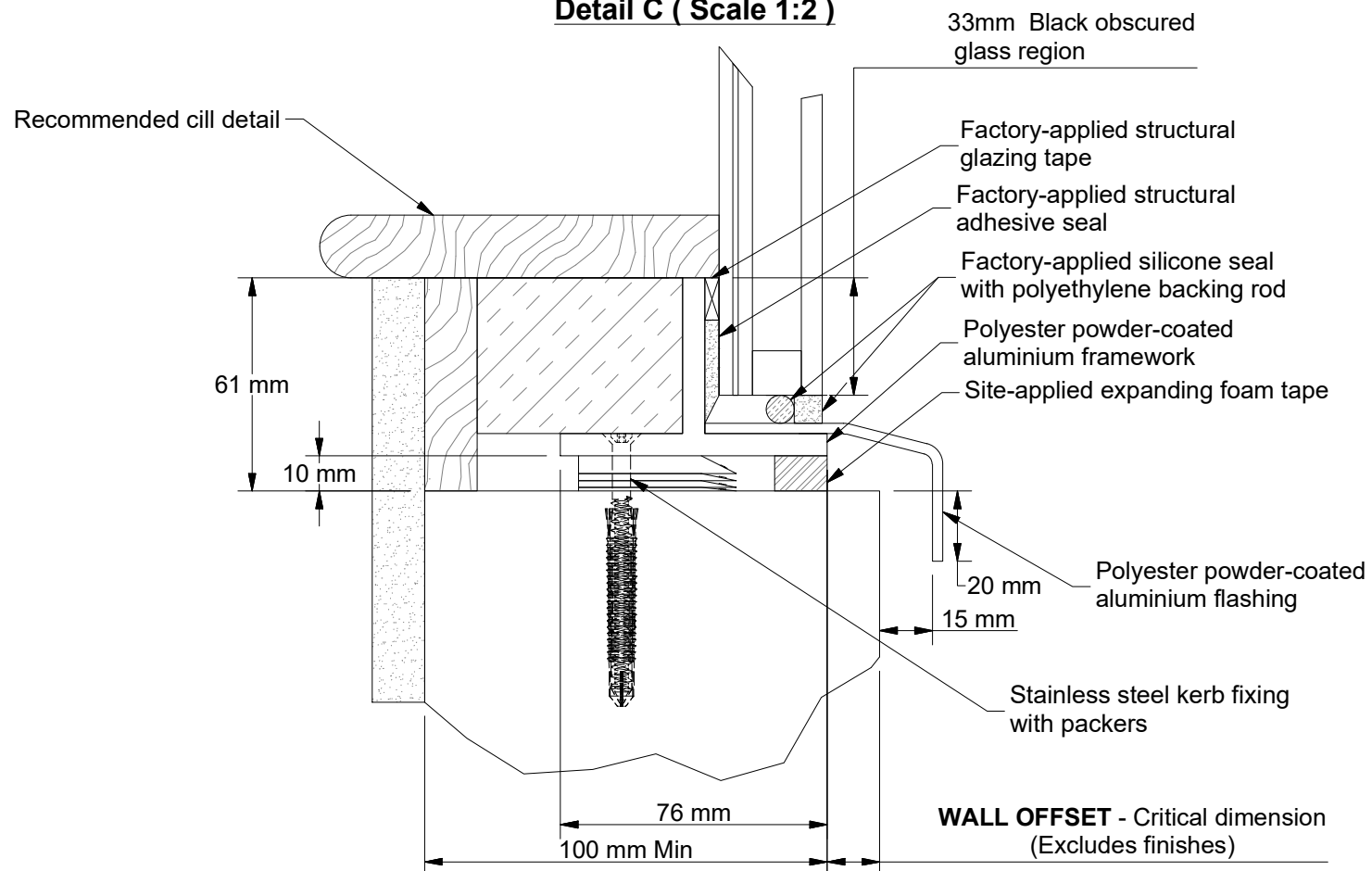

Detail E (Scale 1 : 2)

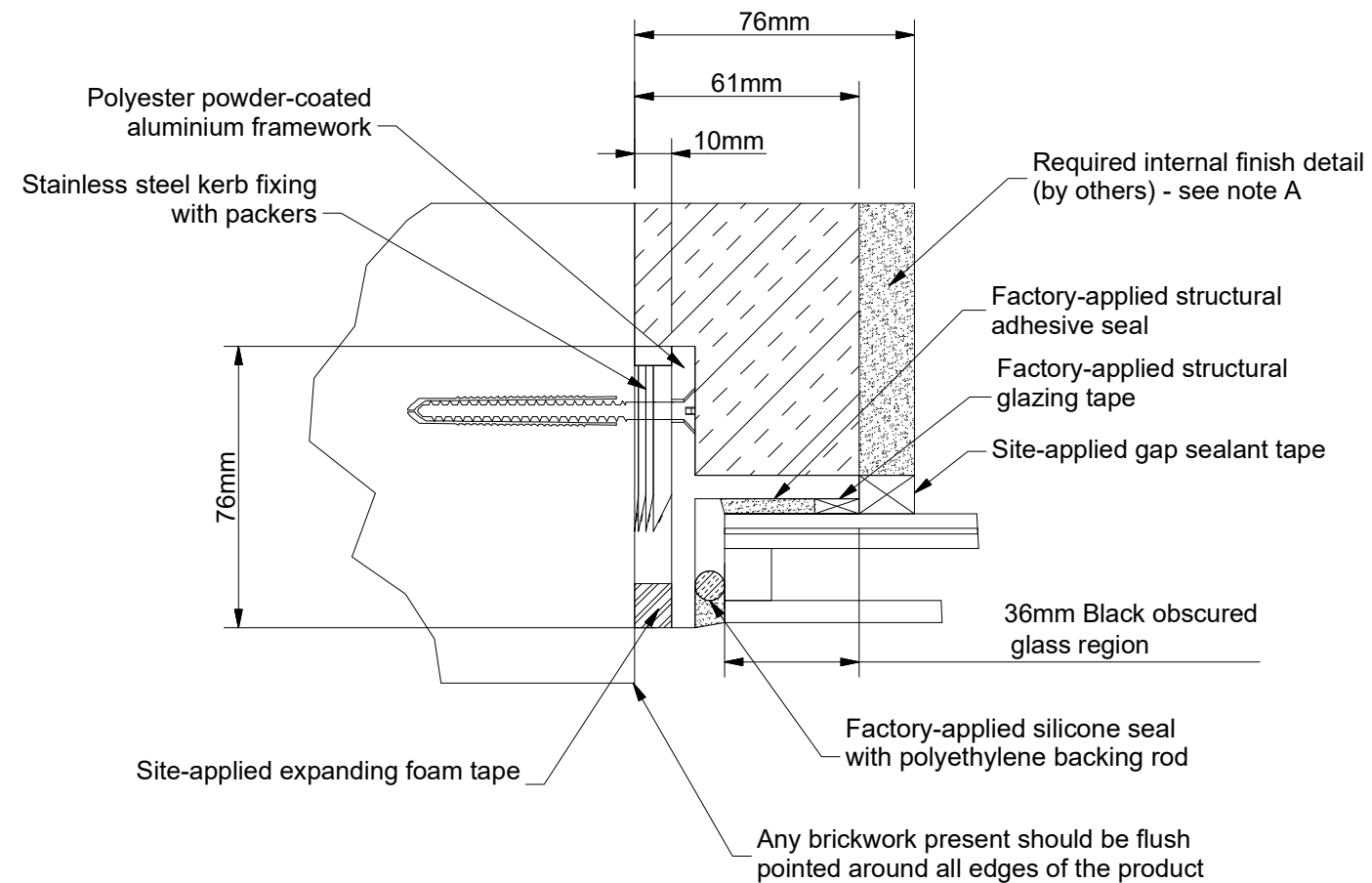

For cross-section locations refer to drawing: 402-ASS-056 (1 of 3)

Standard Glass Specification:

Outer: 6mm Clear HST Toughened
 Spacer: 14mm Black, Silicone, Warm edge, Argon filled
 Inner: 9.5mm Clear Soft Low E Heat Strengthened Laminated

Note A:
 Internal finishes supported on battens with an insulated gap to mask exposed wall mount detail.
 To be constructed (by others) after rooflight installation.

 Saw Mills Road Diss Norfolk IP22 4RG Tel: +44 (0)333 8000 881 Fax: +44 (0)333 8000 882 Email: sales@glazingvision.co.uk Website: www.glazingvision.co.uk	IT IS GLAZING VISION'S POLICY TO CONTINUOUSLY DEVELOP AND IMPROVE OUR PRODUCTS. WE THEREFORE RESERVE THE RIGHT TO MODIFY OR CHANGE THE DETAIL DESIGN AT OUR DISCRETION AND WITHOUT PRIOR NOTICE. THIS DRAWING IS COPYRIGHT AND THE SOLE PROPERTY OF GLAZING VISION LTD. THE DESIGNS/INFORMATION IT CONTAINS ARE PRIVATE AND CONFIDENTIAL. IT MUST NOT BE COPIED, EXHIBITED OR COMMUNICATED TO THIRD PARTIES FOR ANY PURPOSE OTHER THAN THAT FOR WHICH IT WAS ISSUED WITHOUT THE WRITTEN PERMISSION OF GLAZING VISION LTD.	Third angle projection unless otherwise noted. Tolerances: Whole numbers = ±1mm One decimal place = ±0.5mm Two decimal places = ±0.2mm All angles 90±0.5 degrees unless specified IF IN DOUBT - ASK! DO NOT SCALE Supplier to deburr & remove sharp corners	Rev	Revision Description	Drawn/Date	Product: 402 - GV Standard Eaves Flushglaze Description: Eaves Flushglaze	Checked By: JSL
			H	Added note about Black obscured glass region	HTT 05.02.20	Materials: N/A	Check Date: 26.05.20
			I	Corrected span dimension	HL 26.05.20	Finish: N/A Weight: 373.585 kg Quantity: N/A Scale: 1:2	
							Drawn By: JWJ Drawn Date: 25.01.17 Drawing No: 402-ASS-056 (3 of 3)