

The proposed dormer is less than half the height of the main roof slope and the same width as the dormer with permission to the neighbouring flat

Brick party wall

SVP

03 SECTION
005 AA LONG

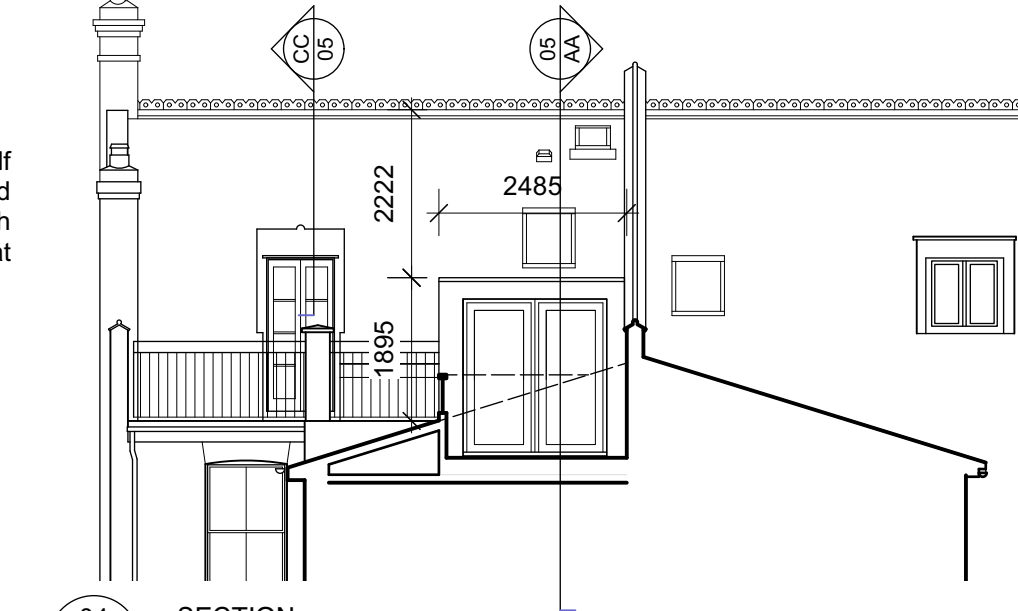

04 SECTION
005 BB SHORT

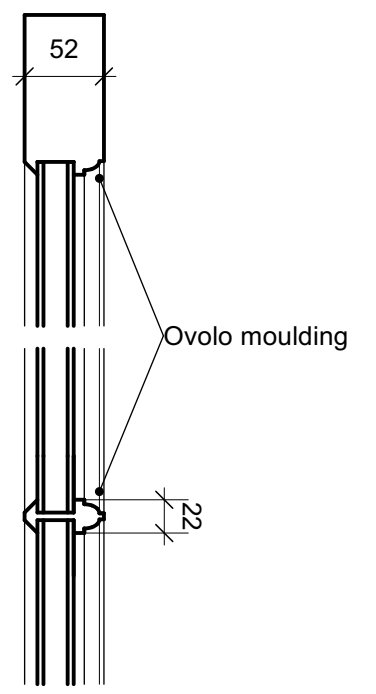

05 CC DOOR FRAME/MULLION 1:5
003 24mm DOUBLE GLAZED TIMBER FRENCH DOORS

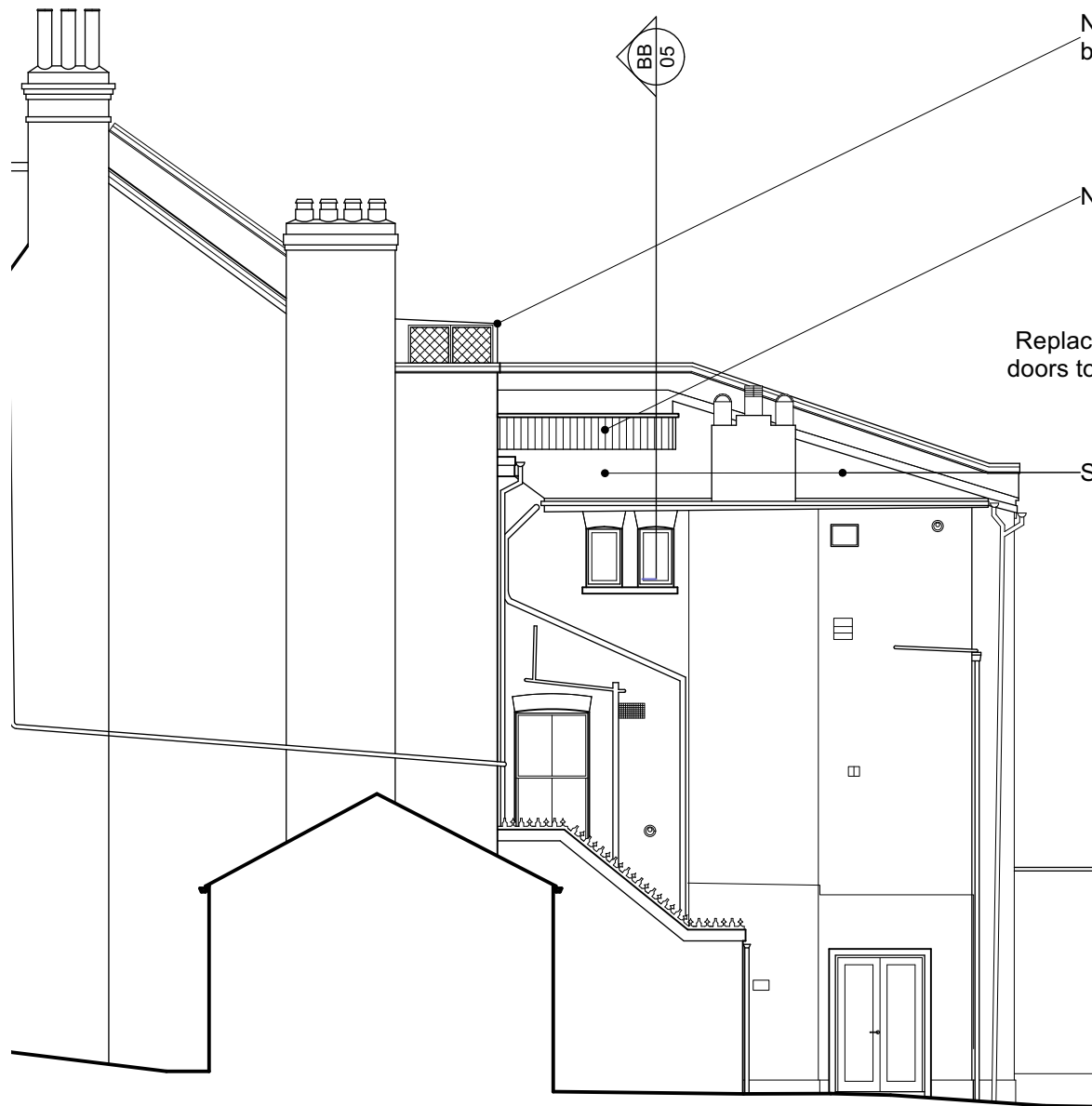

01 ELEVATION
005 SIDE

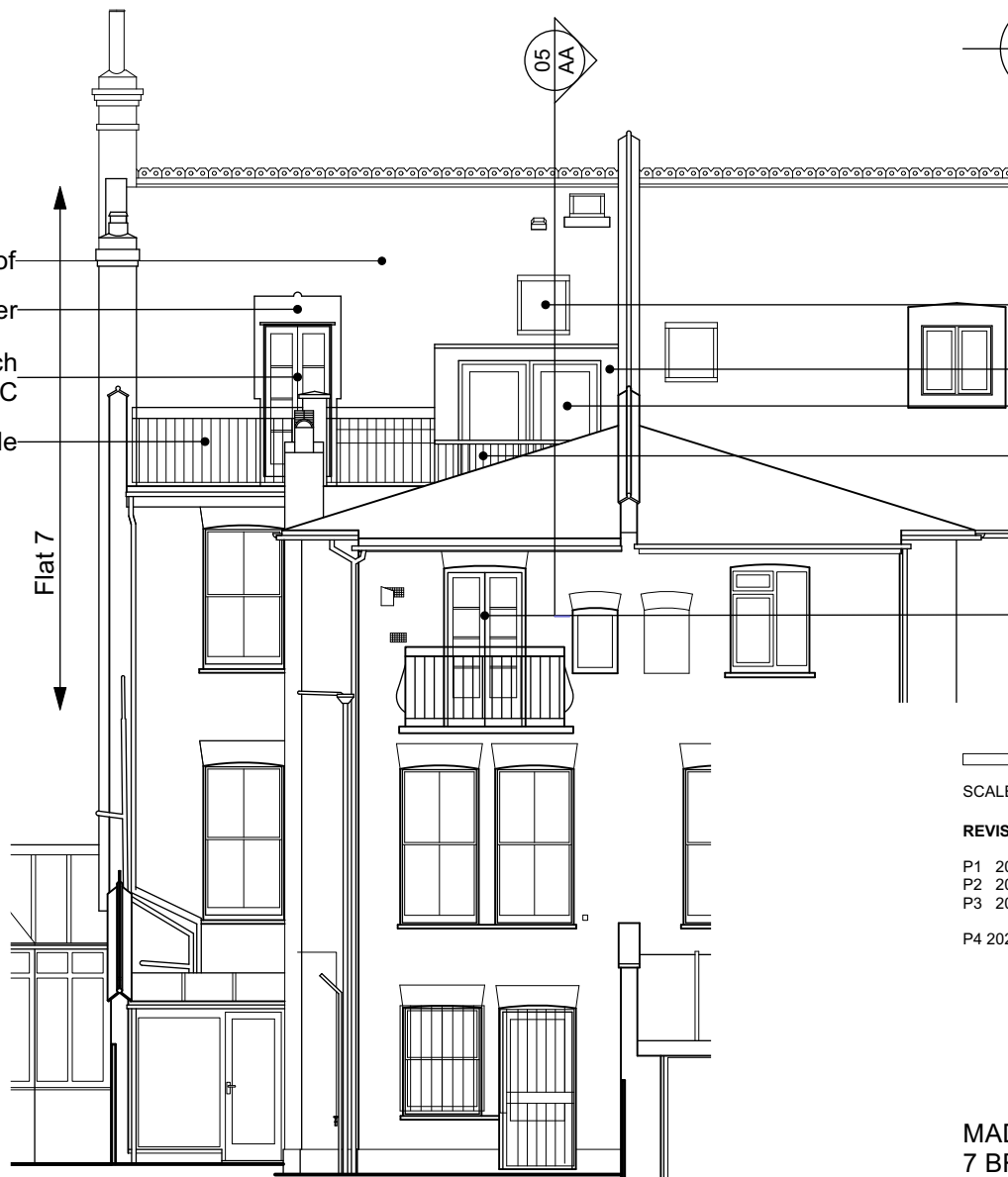

02 ELEVATION
005 REAR

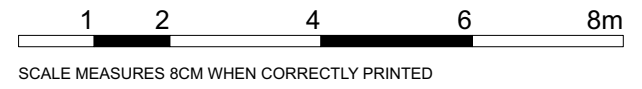

- REVISIONS**
- P1 20221012 ISSUE FOR PLANNING
 - P2 20221124 FRENCH DOORS REPLACED TO MATCH
 - P3 20230113 HEIGHT OF DORMER REDUCED AND WIDTH OF TERRACE REDUCED
 - P4 20230117 ELEVATION OF DORMER AND TERRACE WITH PERMISSION AT FLAT 6 REMOVED FROM DRAWING

MADONNA BAPTISTE
7 BRAMSHILL MANSIONS

ELEVATION 099-005
1:100 @ A3 DJ REV P4