

REMOVE TILED SURFACE, PATCH AND REPAIR WALL TO RECEIVE NEW FINISHES.

REMOVE EXISTING PLUMBING FIXTURES AND BATHTUB. ALL SERVICE CONNECTIONS TO BE DISCONNECTED AND RELOCATED. PREPARE WALLS FOR NEW FINISHES.

**1** 1:25@ A1  
EXISTING NORTH ELEVATION

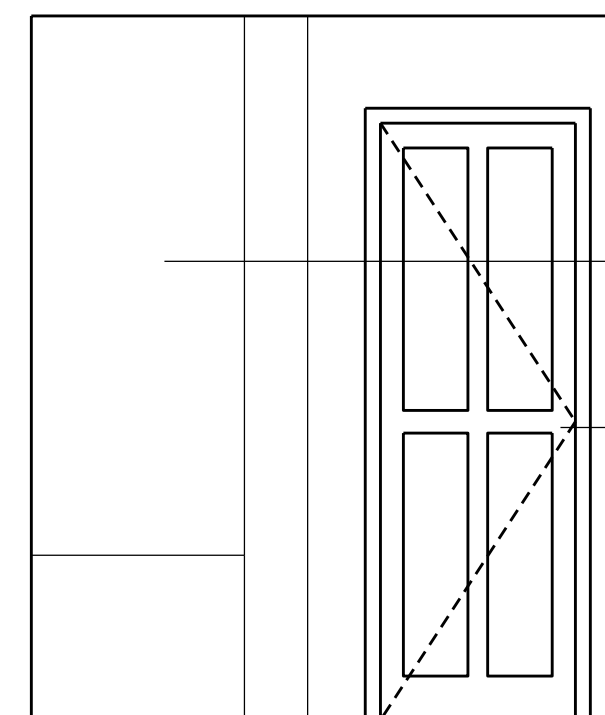

REMOVE TILED SURFACE, PATCH AND REPAIR WALL TO RECEIVE NEW FINISHES.

EXISTING ENSUITE PARTITION, DOOR, TRIM, FRAME AND HARDWARE TO BE REMOVED. PATCH AND REPAIR WALL AND FLOOR TO RECEIVE NEW FINISHES.

**2** 1:25@ A1  
EXISTING EAST ELEVATION

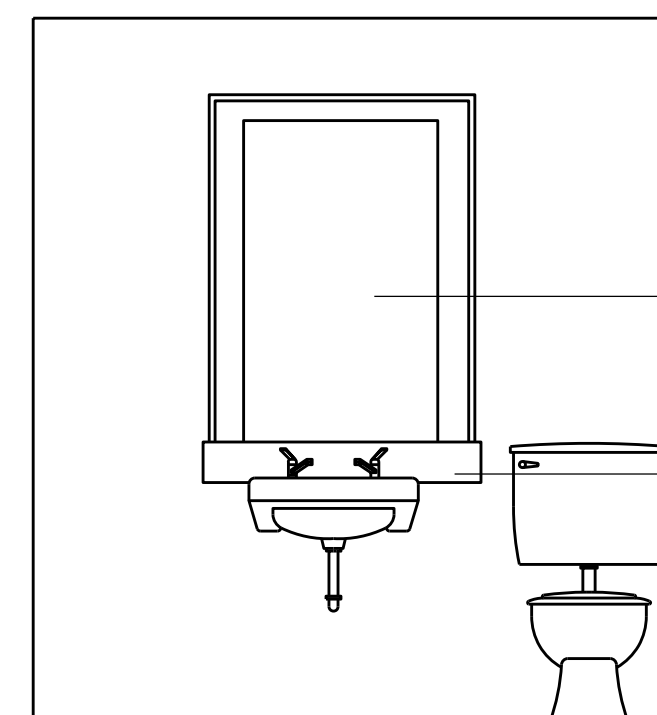

EXISTING WINDOW TO BE INFILLED. WALL FINISHES TO BE MADE GOOD ON BOTH SIDES.

PLUMBING FIXTURES, SANITARYWARE AND TOILET ACCESSORIES TO BE REMOVED. PATCH AND REPAIR WALL SURFACE FOR NEW FINISHES.

**3** 1:25@ A1  
EXISTING SOUTH ELEVATION

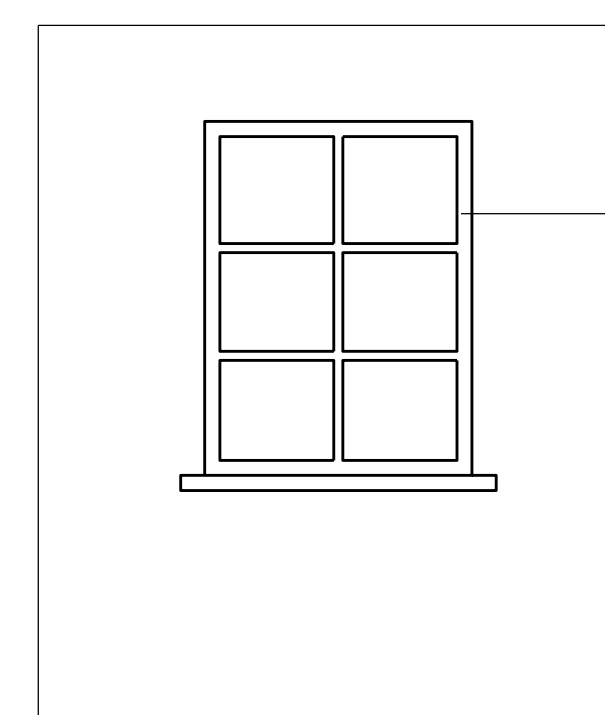

EXISTING WINDOW RETAINED AND REDECORATED.

**4** 1:25@ A1  
EXISTING WEST ELEVATION

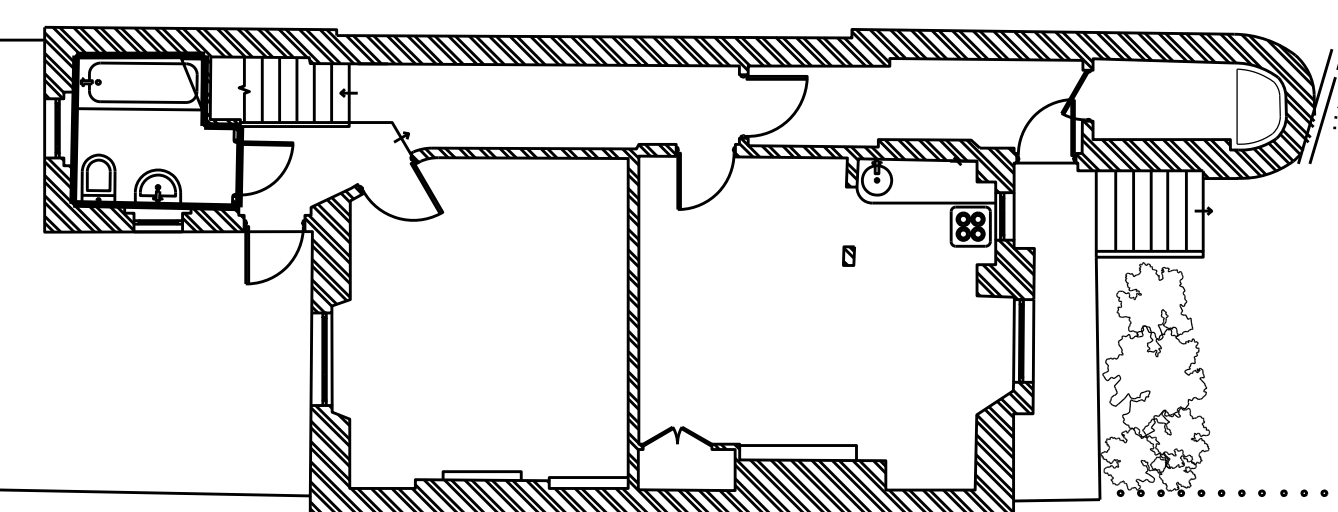

**KEY** 1:100 @ A1  
PLAN

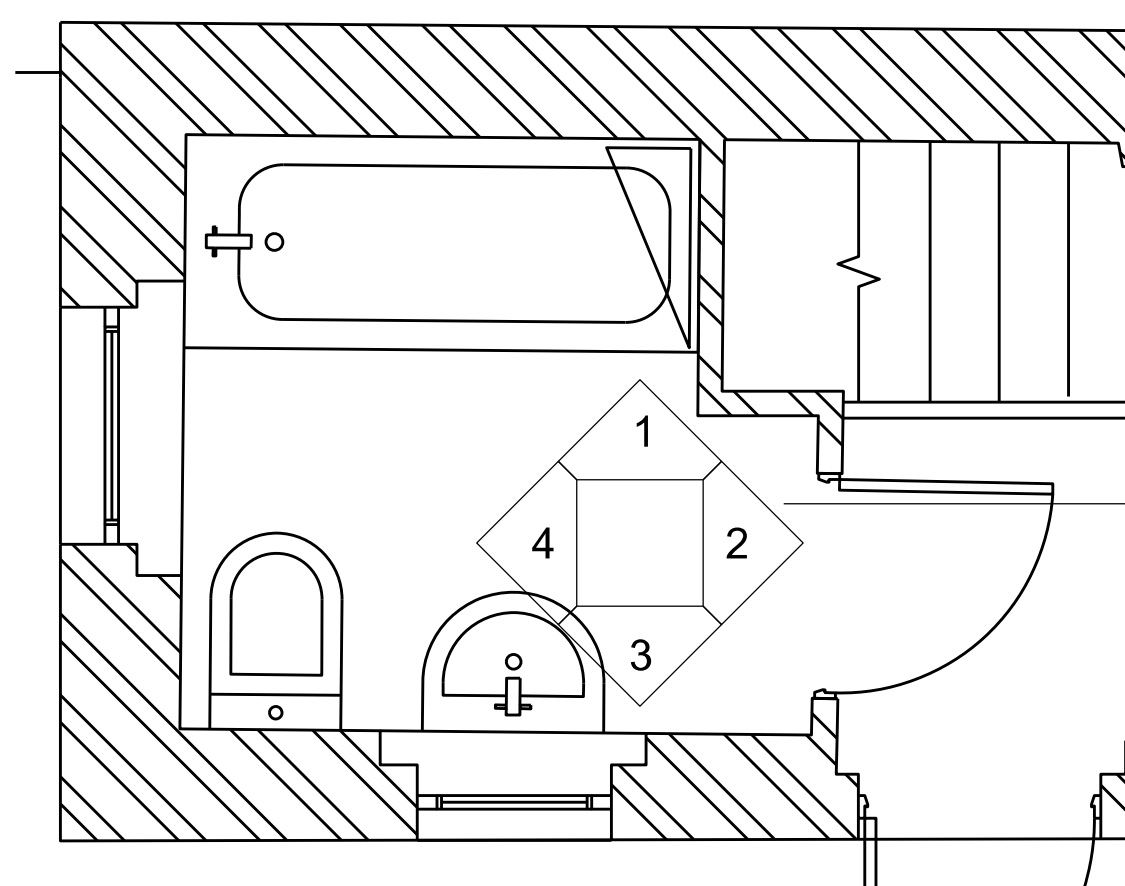

REMOVE FLOORING, REPAIR AND PREPARE FLOOR FOR SCHEDULED FINISHES. FINISHES TO BE DETERMINED.

**5** 1:25@ A1  
PROPOSED ROOM PLAN

0 1 2 3  
SCALE IN METRES @ 1:25

01	AUG 22	PLANNING APPLICATION ISSUE	SC
REV	DATE	NOTES	INT.
PROJECT			
91A BELSIZE LANE			
DRAWING TITLE			
EXISTING INTERNAL ELEVATION, LOWER GROUND WC			
STATUS			
PLANNING			
DATE	DRAWN	CHECK	SCALE @ A1 1:25
AUGUST 2022	SC	JC	SCALE @ A3 1:50
PROJECT NUMBER	BLOCK	CODE	TYPE & REVISION NUMBER LETTER
0484_A_			0120 T00

