

Notes
 Do not scale from this document, unless for the purposes of planning applications where a scale bar is provided. Refer to figured dimensions only. All dimensions to be verified on site prior to construction. Report all discrepancies or ambiguities to the Document Originator immediately. This document is to be read in conjunction with relevant documents, drawings and standards.

Details Legend

	VCL
	EPDM
	DPM
	DPC
	Breather Membrane
	Roof Waterproofing

Breather membrane position within the wall build-up TBC

CAVITY BARRIERS NOTE:

The cavity barriers indicated on this drawing are shown for strategy purposes ONLY. Exact locations of cavity barriers and arrangement with individual cladding systems to be developed in coordination with subcontractors, fire engineer and building control as part of Facade CDP responsibilities

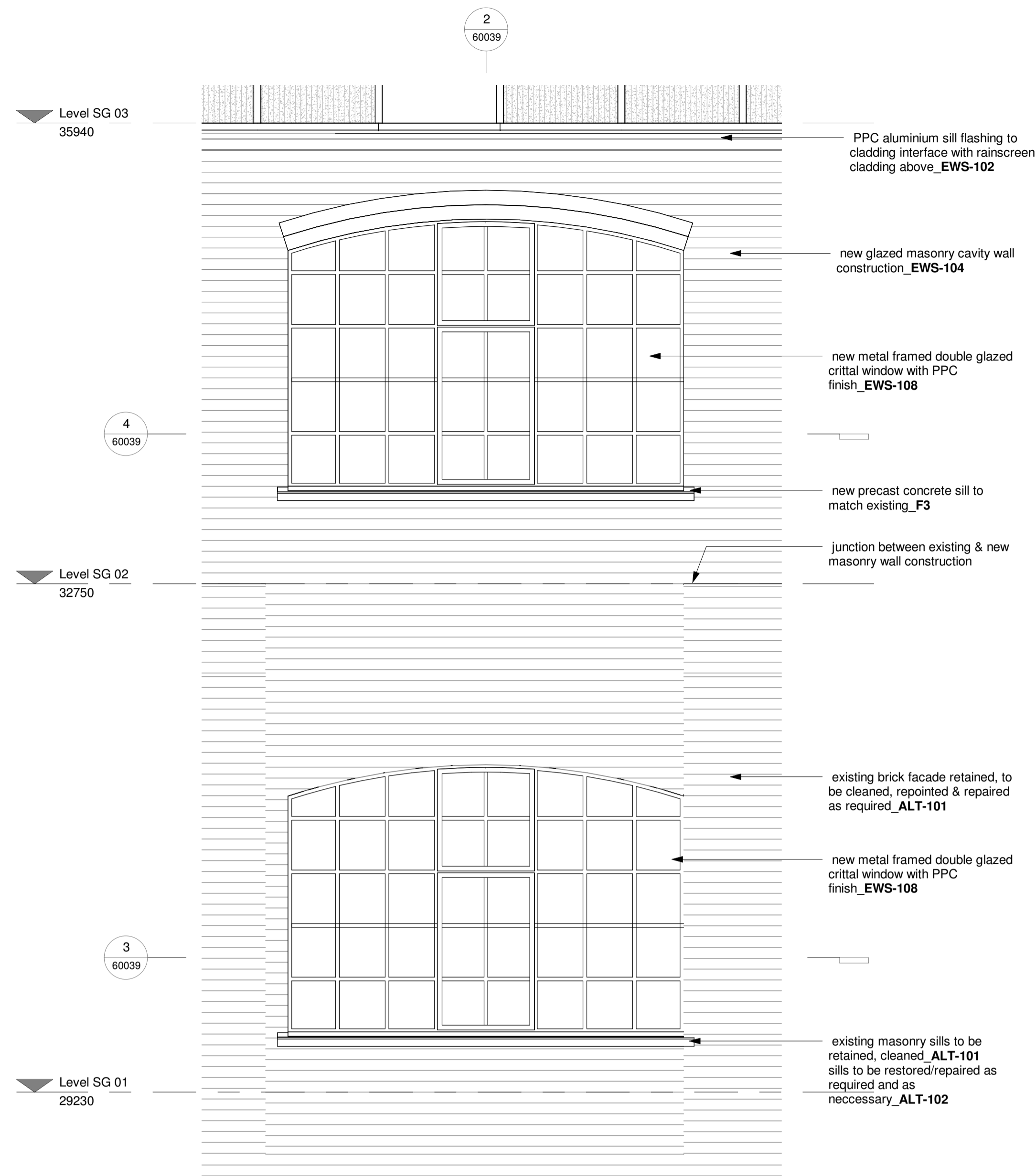

1 South Bay Elevation
1 : 25

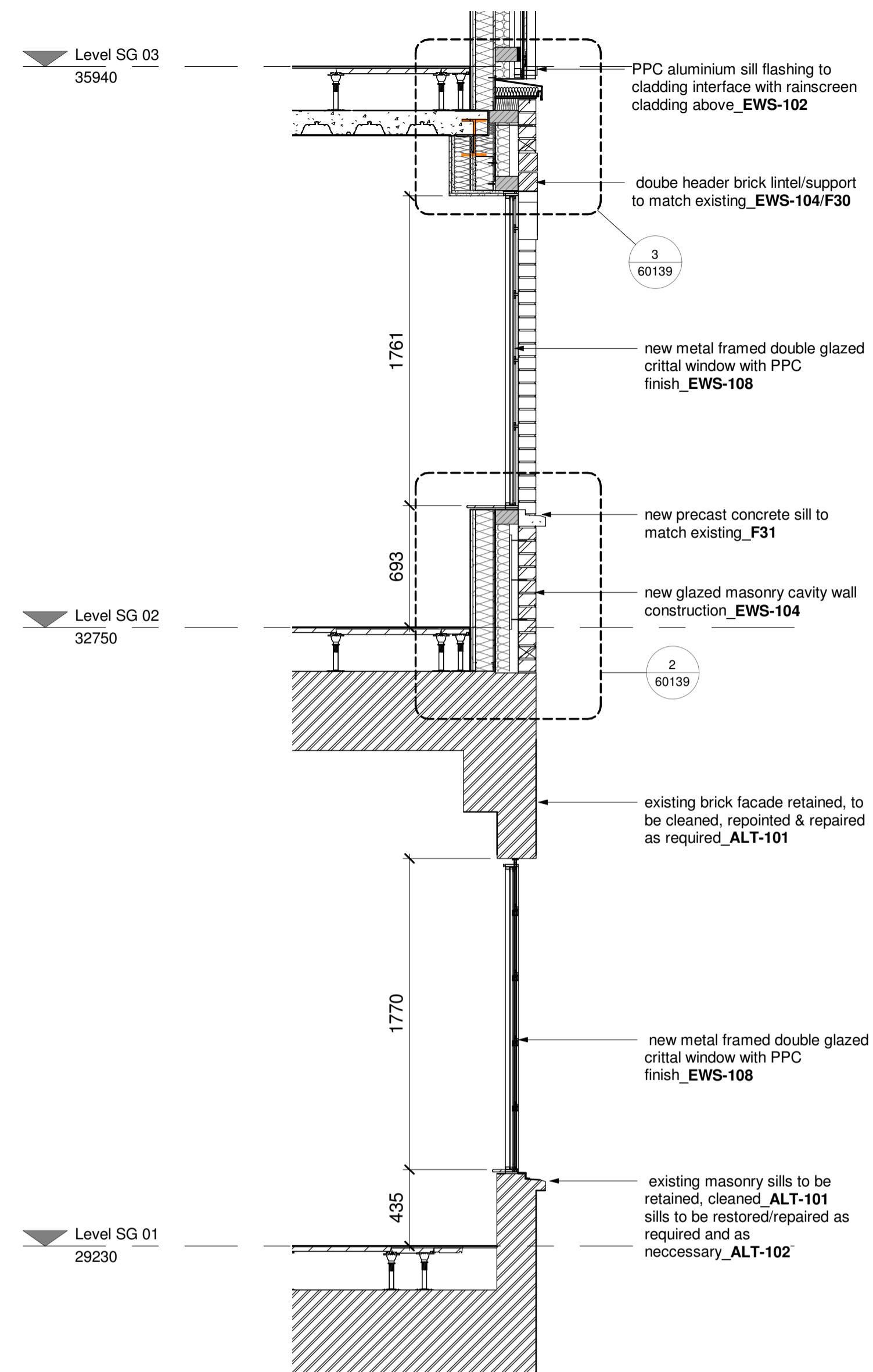

2 South Bay Section
1 : 25

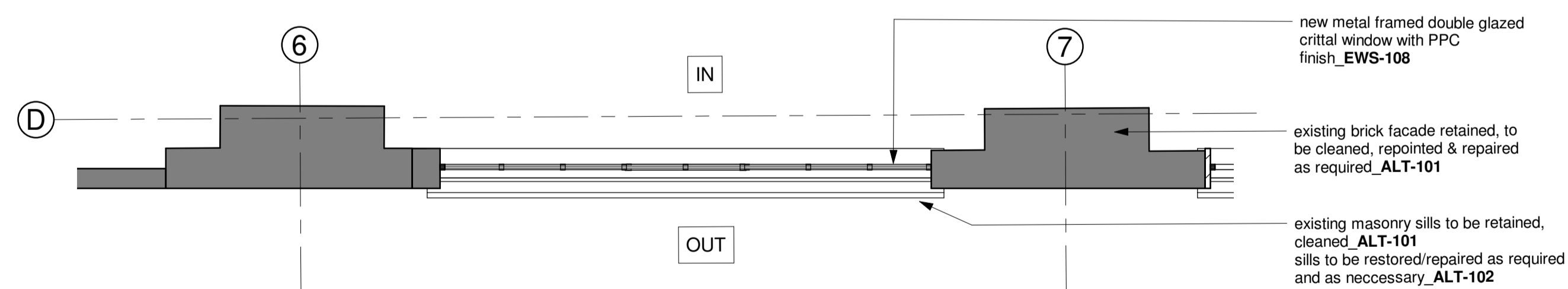

3 South Bay Plan - First Floor
1 : 25

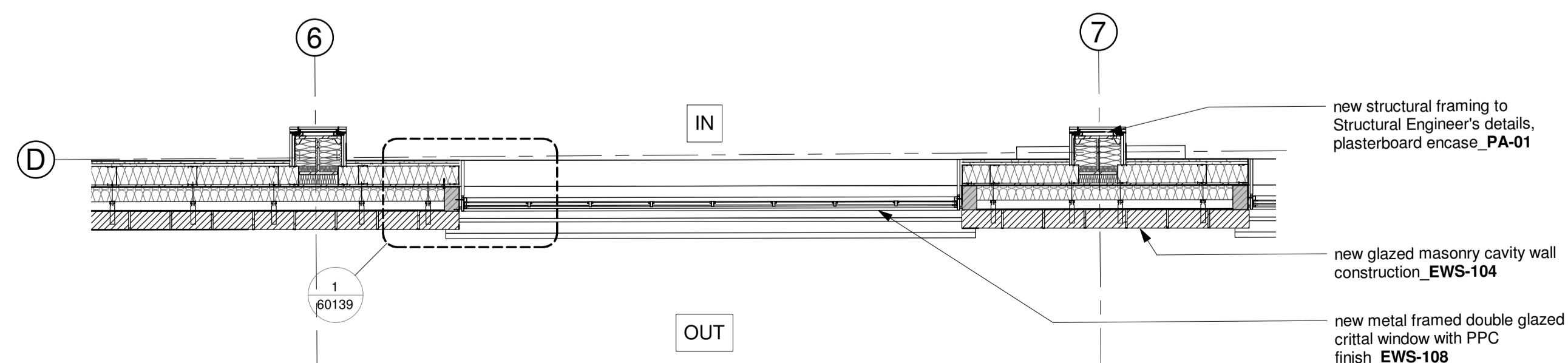

4 South Bay Plan - Second Floor
1 : 25

P03	05/08/22	General updates inc. project title	DJ	CJ
P02	01/04/22	General updates	JAP	DJ
P01	27/01/22	First Issue	GB	DJ

Rev	Date	Notes	Dm	Chk'd
-----	------	-------	----	-------

Document Originator

AWW

London 106 Weston Street, SE1 3GB 020 7160 6000
 Plymouth East Quay House, PL4 0HX 01752 261 262
 Bristol plot + mark, 48-52 Baldwin Street, BS1 1QB 0117 923 2535
 RIBA Chartered Practice www.aww-uk.com

Client
 SPAN GROUP

AWW Project Number 4498
 Project Stage Stage 4

Project Title
 60-70 Shorts Gardens & 14-16 Betterton Street
 London

Title
 EN-051 Building Envelope - SG South Elevation -
 Level 01 & 02

Scale @ A1 Document Status
 As S2 - Suitable for Information

Project	Origin	Volume	Level	Type	Role	Number	Rev
SHG	AWW	XX	XX	DR	A	60039	P03