



SITE PLAN

Scale 1:500

0 5m 10m
SCALE 1:500
 WHEN PRINTED ON A3 SIZE PAPER

SITE PLAN

Scale 1:500

0 5m 10m
SCALE 1:500
 WHEN PRINTED ON A3 SIZE PAPER

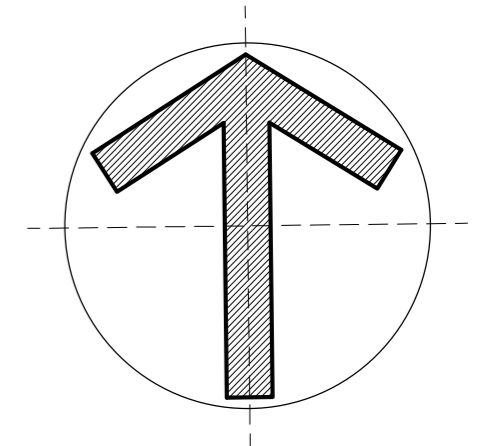

HOME AND OFFICE

CHARTERED ARCHITECTS - PLANNERS

STUDIO: 39 FORESTDALE, SOUTHGATE, LONDON N14 7DY
 T:07561 100080 F:020 8351 0026 Em: homearchitect@btinternet.com

ARCHITECT:

MICHAEL HAPESHIS
 BA(Hon's), DipArch(Hon's), RIBA, ARB, ETEK

STRUCTURAL ENGINEER

BUILDING SERVICES ENGINEER:

QUANTITY SURVEYOR:

DRAWING TITLE **BLOCK PLAN**

PROJECT TITLE / CLIENT
THE BENGAL LANCER
 RELOCATION OF ENTRANCE / SHOP FRONT
 253 KENTISH TOWN ROAD, LONDON NW5 2JT

CLIENT:
 AKRAM ALI, Esq

Job No:		DRAWING NO	
CI/SfB		SITE PLAN	
10=1		REVISION SUFFIX	
Scale		DRAWN	
1:500	DATE	MPH	CHECKED
	23.09.2022		M.HAPESHIS