

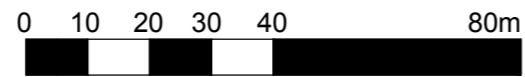

**ORDNANCE SURVEY PLAN**  
 scale 1:1250

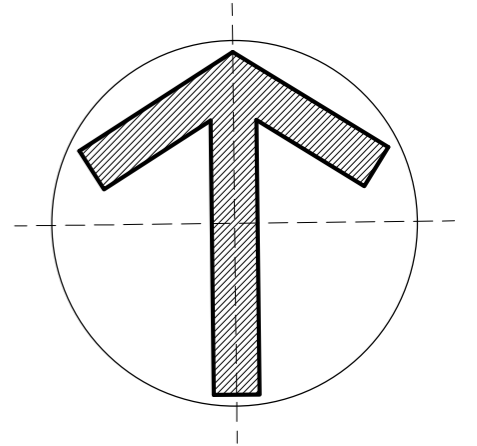

**SCALE 1:1250**  
 WHEN PRINTED ON A3 SIZE PAPER



**HOME AND OFFICE**  
 CHARTERED ARCHITECTS - PLANNERS

STUDIO: 39 FORESTDALE, SOUTHGATE, LONDON N14 7DY  
 T:07561 100080 F:020 8351 0026 Em: homearchitect@btinternet.com

ARCHITECT:  
**MICHAEL HAPESHIS**  
 BA(Hon's), DipArch(Hon's), RIBA, ARB, ETEK

STRUCTURAL ENGINEER

BUILDING SERVICES ENGINEER:

QUANTITY SURVEYOR:

DRAWING TITLE **LOCATION PLAN**

PROJECT TITLE / CLIENT  
**THE BENGAL LANCER**  
 RELOCATION OF ENTRANCE / SHOP FRONT  
 253 KENTISH TOWN ROAD, LONDON NW5 2JT

CLIENT:  
 AKRAM ALI, Esq

Job No:	DRAWING NO	<b>LOC PLAN</b>	
CI/SfB	10=1	REVISION SUFFIX	
Scale	DATE	DRAWN	
1:1250	23.09.2022	MPH	CHECKED
			M.HAPESHIS