

External Elevation

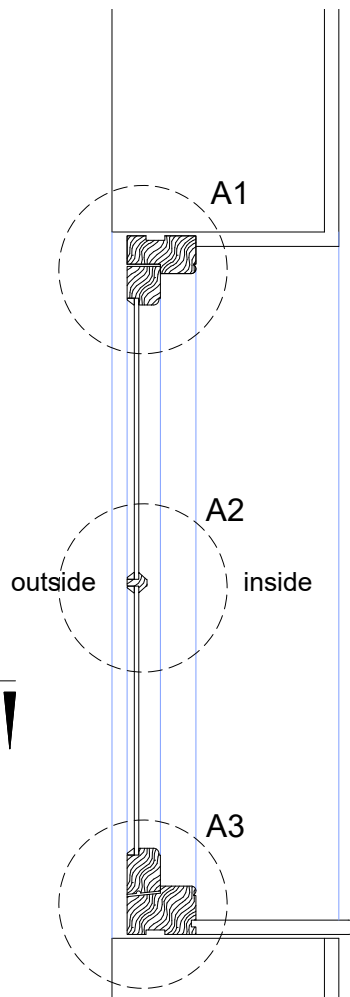

Section AA

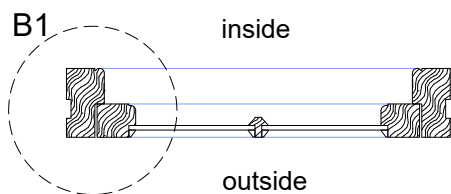

Section BB

Existing brick arch and stone sill retained and refurbished as necessary.

NOTES:

1. Glass to match the existing in weight and thickness.
2. Unless otherwise stated, joinery is to be in hardwood from a sustainable source.
3. All opening casements to be weatherstopped.
5. Please refer to dwg No 2105/BC/JJ/104 for large scale details
6. All dimensions to be checked on site prior to fabrication.
7. sills to have min 30mm overhang unless agreed otherwise.



P.H.D. ASSOCIATES BRAEMAR HOUSE WATER LANE STANSTED, ESSEX CM24 8BJ TEL: 01279 817342 FAX: 01279 647086 EMAIL: INFO@PHDASSOCIATES.CO.UK		Project	Oxford House Hostel Tavistock Place, London WC1H 9RE	Date	18-08-2022
		Drawing	Joinery Details - New casement window W1-09&10and W0-08&09	Drawn By	SHD/ADC/VM
				Scale	1-10at A4
				Drawing Number	2105/BC/JJ/004