

REVISION HISTORY			
REV	DESCRIPTION	DATE	APPROVED

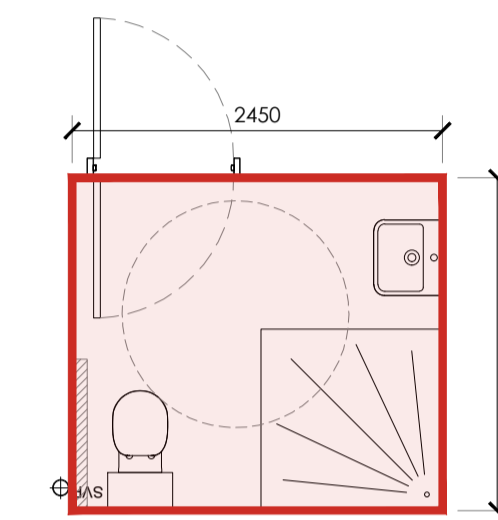

2 AD Part M4(3) Adaptable Bathroom
Diagram 3.16C Scale: 1:50

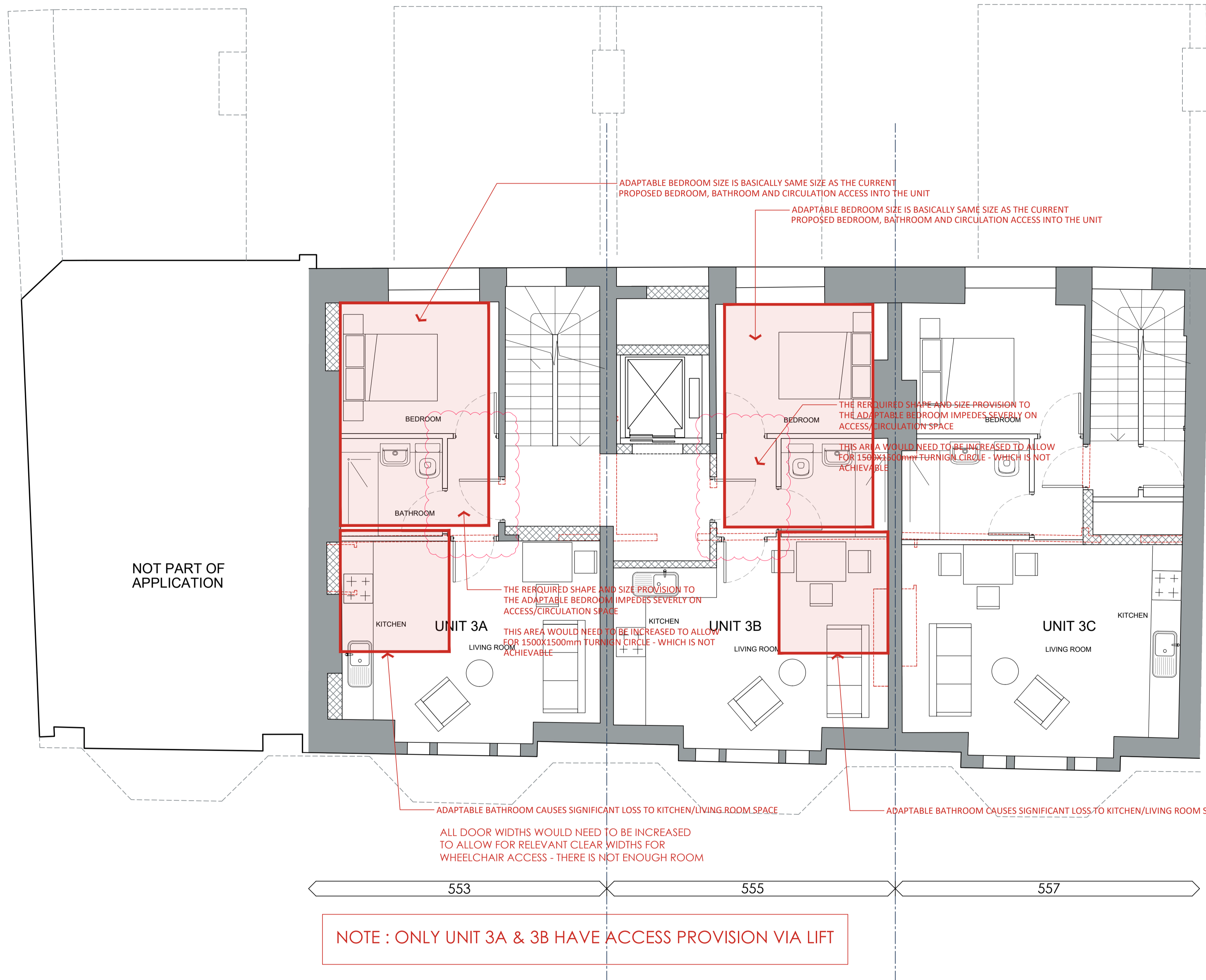
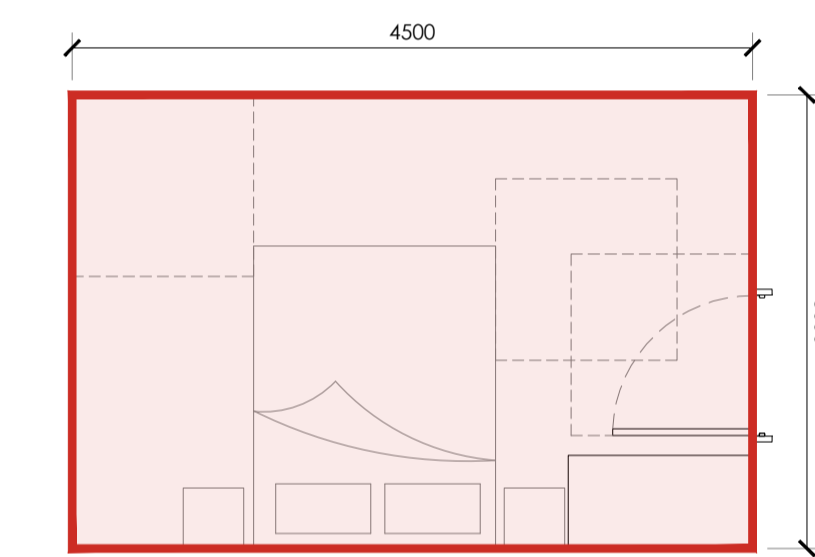

3 Adaptable Bedroom
Scale: 1:50

- LEGEND:
- EXTENT OF PROPOSED DEMOLITIONS
NOTE : Demolitions to be Reviewed by Structural Engineer.
 - EXTENT OF RETAINED EXISTING STRUCTURE
 - NEW PROPOSED (SOLID) INTERNAL WALLS
 - NEW PROPOSED (STUDWORK) INTERNAL WALLS

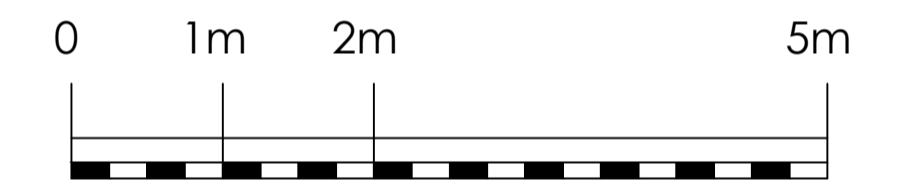

Scale Bar

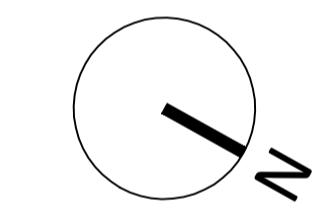

DO NOT SCALE THIS DRAWING - USE DIMENSIONS
The Contractor is to check and verify all dimensions on site before starting work and report any omissions or errors.

This drawing is to be read in conjunction with all relevant consultants and specialists drawings.

This drawing is copyright

This drawing is issued for the sole and exclusive use of the named recipient. Distribution to any third party is on the strict understanding that no liability is accepted by bcr-infinity architects for any discrepancies, errors or omissions that may be present, and no guarantee is offered as to the accuracy of information shown.

bcr-infinity architects

RIBA
Chartered Practice

Cambridge:
1 Wellington street
CB1 1HW
T 01223 366717

Bury St Edmunds:
8 Angel Hill
IP33 1UZ
T 01284 727710

www.bcr-infinityarchitects.co.uk
e: studio@bcr-infinityarchitects.co.uk

Client
GLENCAR CONSTRUCTION
Project
551-557 Finchley Road

Drawing Title:
PROPOSED - THIRD FLOOR GA
Drawing Status:
SK04_20220729

Project No: 22-055	Dwg No: SK04	Rev: -	Drawn: JH	Checked: MA	Scale @ A1: 1:50
CAD Reference: SK04-29072022				Date: 29/07/2022	Scale @ A3: 1:100

1 THIRD FLOOR - AS PROPOSED
Scale: 1:50

SK04_20220729 - Third Floor Overlay Showing Impact of Adaptable Layout

BCRi Architects