

P e l l F r i s c h m a n n

O2 Finchley Road

Basement Impact Assessment

This report is to be regarded as confidential to our Client and is intended for their use only and may not be assigned except in accordance with the contract. Consequently, and in accordance with current practice, any liability to any third party in respect of the whole or any part of its contents is hereby expressly excluded, except to the extent that the report has been assigned in accordance with the contract. Before the report or any part of it is reproduced or referred to in any document, circular or statement and before its contents or the contents of any part of it are disclosed orally to any third party, our written approval as to the form and context of such a publication or disclosure must be obtained.

Report Ref.	104878-PEF-ZZ-ZZ-RP-S-003013					
File Path	https://pellf.sharepoint.com/sites/104878/Shared Documents/General/01 - WIP/Documents/Structural Engineer/Reports/BIA/104878-PEF-ZZ-ZZ-RP-S-003013					
Rev	Suit	Description	Date	Originator	Checker	Approver
1	S4	For planning.	Jan-22	K Stone	A Gaftea	M Hitchens
2	S4	Post audit revision	July-22	K.Stone /J.Bret	K Stone	A Gaftea
Ref. reference. Rev revision. Suit suitability.						

Prepared for

LS (Finchley Road) Limited

100 Victoria Street
London
SW1E 5JL

Prepared by

Pell Frischmann

5th Floor, 85 Strand
London
WC2R 0DW

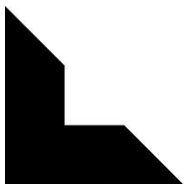

Landsec

Pell Frischmann

Contents

Executive summary

1	Introduction	1
1.1	Author's Qualifications	1
1.2	Scope	1
2	Proposed Development	2
2.1	Detailed Plots	4
2.2	Outline Plots	4
3	The Site	6
3.1	Location	6
3.2	Geotechnical features	6
3.3	Third Party Assets	7
4	Ground Conditions	9
4.1	Soil conditions	9
4.2	Groundwater and Hydrology	9
5	Outline Construction Methodology	10
5.1	No Site Constraints Methodology	10
5.2	Methodology With Site Constrains	11
6	Screening	13
6.1	Groundwater Flow	13
6.2	Ground Stability	13
6.3	Surface flow and flooding	14
7	Scoping and Potential Impacts	16
7.1	Groundwater Flow	16
7.2	Ground Stability	16
7.3	Surface flow and flooding	17
8	Basement Impact Assessment	18
8.1	Detailed Plots N4 and N5	18
8.2	Existing O2 Centre	19
8.3	Outline Plots	20
8.4	Other Considerations	21
9	Residual Risks	22
9.1	Groundwater Flow	22
9.2	Ground Stability	22
9.3	Surface flow and flooding	22
10	Conclusions and Recommendations	23
11	References	24

Figures

Figure 1	Plot Locations	3
Figure 2	Extent of Proposed Basements for Buildings N4 & N5	4
Figure 3	Existing O2 Basement Structure	5
Figure 4	Site Location	6
Figure 5	Adjacent infrastructure to plot S8	8

Figure 6 Published Geology9
Figure 7 Typical cross-section through proposed basements of N4 and N5 18
Figure 8 Cross-section through proposed scheme showing retained basement slab and walls 19
Figure 9 Support to existing basement walls during construction 20

Tables

Table 1 Proximity of railway assets7
Table 2 Summary of stratigraphical succession9
Table 3 Battered slopes excavation 10
Table 4 Bottom-Up Construction Method - Simplified 11

Appendices

Appendix A Existing O2 Centre Drawings

Non-Technical Summary

Site Name	The O2 Masterplan Site
Location	The Site is located in Finchley, within the London Borough of Camden (LBC). It is approximately 5.7 ha in size and currently comprises the O2 Centre, which is arranged over three floors and contains a cinema, a mix of retail units, restaurants and cafes, a health club, a community room and a Sainsbury's store; hard-standing, which is used as a car-park with space for 520 vehicles and a Homebase store, and to the western part of the Site are two purpose-built car showrooms and a builder's merchant.
Development proposal	<p>Two of the three buildings that form part of the detailed planning application, N4 and N5, will include localised basements within their proposed footprints. The proposed buildings will be of in-situ RC frame construction, with the basement areas constructed within an open excavation.</p> <p>One of the areas considered in the outline application is currently occupied by the existing O2 Centre. Within the building's footprint, there is an existing half basement with retaining walls on the north and eastern elevations. Consideration is being given to lowering the base slab by 1.0m. The current elevation of Finchley road is 55m AoD and the existing basement extends to 48m AoD. The proposed basement deepening would make the total depth of the basement 8m below the level of Finchley Road.</p>
Ground Conditions	The geology of the area consists of the bedrock of the London Clay Formation present over the whole site. An intrusive investigation has been completed by RSK Ltd. and a factual report has been issued. The borehole logs confirm the presence of the London Clay and record variable thickness of Made Ground across the site. Error! Reference source not found.
Screening & Scoping	<p>The screening process identified a number of potential issues which have been carried forward to the scoping stage.</p> <p>The scoping stage identified the potential impacts shown by the screening process to need further investigation. The potential impacts of each of the matters of concern identified in the screening are identified and addressed with appropriate mitigation measures being recommended.</p>
Basement Impact Assessment	<p>A Basement Impact Assessment has been undertaken using best practice methodology in accordance with Camden Planning Guidance: Basements (January 2021).</p> <p>The BIA concluded that the proposed works for the detailed plots N4 and N5 and the existing basement of the O2 Centre, will not result in any specific issues relating to land or slope instability, detrimental effect on the local hydrogeology and hydrology of the site, nor to have any adverse impact on neighbouring infrastructure. Building damage resulting from ground movements are qualitatively assessed as Category 0.</p> <p>It is however recommended that monitoring points are installed on the existing basement wall and /or levelling points on the adjacent roadways, to verify the anticipated negligible impact of the works on adjacent infrastructure. Similarly, for the construction of block N5 over the existing Thames Water sewer, a ground movement monitoring regime will be in place as part of the build-over agreement. It is noted that the impact of construction works on Thames Water infrastructure is the subject of a separate detailed assessment.</p> <p>With regards to outline plots N3, N6 and N7, these are of sufficient distance from existing infrastructure that open excavations are likely to be feasible with negligible impact but if required, supported excavations will be undertaken. For plot S8, rail infrastructure to the south and existing buildings to the west and north lie within the zone of influence of basement works.</p> <p>For S8 and all the proposed buildings forming part of the outline planning application, the BIA will be updated (or additional BIAs prepared) to reflect the final design proposals at the reserved matters stage.</p>

1 Introduction

This Basement Impact Assessment has been prepared and submitted by Pell Frischmann on behalf of LS (Finchley Road) Limited (the “Applicant”), to support an application made in part in detail and part in outline (the “Application”) for the demolition and redevelopment of land encompassing the O2 Centre and associated car park, Homebase store, car showrooms and a Builder’s Merchant (the “Site”) within the London Borough of Camden (“LBC”).

Development Plots N3-E, N4 and N5 and the associated landscaping, access roads and infrastructure form the detailed element of the Application which extends to 1.79ha and these proposals are referred to as the “Detailed Proposals”.

The remainder of the Application (comprising Development Plots N1, N2, N3, N6, N7, S1 and S8) is submitted in outline and these proposals are referred to as the “Outline Proposals”.

The Detailed Proposals and Outline Proposals together are referred to as the “Proposed Development”.

Full details and scope of the Applications is described in the submitted Planning Statement, prepared by Gerald Eve LLP.

This report sets out a Basement Impact Assessment (BIA) which is in accordance with the generic procedures found in Camden Planning Guidance (CPG): Basements to support the policies in the Camden Local Plan 2017.

The aim of the BIA process is to assess if the proposed basement works planned as part of the site development will have a detrimental impact on the surroundings with respect to groundwater, local and regional hydrogeology, land stability, and in particular to assess whether the basement development will affect the stability or integrity of adjacent infrastructure.

A desk study has been undertaken by Pell Frischmann (document reference 104878-PEF-ZZ-XX-RP-GG-600002, dated January 2022) and is referred to where relevant.

1.1 Author’s Qualifications

This report has been prepared by Kevin Stone who is a chartered Civil Engineer with over 30 years experience in geotechnical and geo-environmental engineering and Jerome Bret a Geotechnical Engineer with an MEng Degree in Civil Engineering.

1.2 Scope

The scope of this report is (i) to screen and scope the entire site in general accordance with the CPG basements Jan 2021 (ii) to provide a BIA relevant to the detailed planning application for the plots N4 & N5. It is noted that significant Thames Water infrastructure runs beneath these plots and a detailed assessment in consultation with Thames Water is currently being prepared (ref: 4602_001-PEF-ZZZ-XXX-RP-C-000001)

2 Proposed Development

The Application is for the following Proposed Development:

“Part full and part outline planning permission comprising the following:

Detailed planning permission for Development Plots N3-E, N4, and N5 including demolition of existing above ground structures and associated works, and for residential development (Class C3) and commercial, business and service (Class E) uses in Development Plot N3-E, residential development (Class C3) and local community (Class F2) and commercial, business and service (Class E) uses in Development Plot N4, and residential development (Use Class C3) and commercial, business and service uses (Class E) uses in Development Plot N5 together with all landscaping, public realm, cycle parking and disabled car parking, highway works and infrastructure within and associated with those Development Plots.

Outline planning permission for Development Plots N1, N2, N3, N6, N7, S1 and S8 including the demolition of all existing structures and redevelopment to include residential development (Class C3) commercial, business and service uses (Class E), sui generis leisure uses (including cinema and drinking establishments) together with all landscaping, public realm, cycle parking and disabled car parking, highway works and infrastructure within and associated with those Development Plots.”

The Application is submitted in hybrid form – this means that (part of the application is made in detail and part is made in outline).

The Application site has been subdivided into 10 Development Plots (N3-E, N4 and N5 N1, N2, N3, N6, N7, S1 and S8).

The first three Development Plots (N3-E, N4 and N5), located in the centre of the Site, are submitted in detail, and form the first phase – “Detailed Phases”.

Development Plots S8, N7 and N6 located in the west of the Site are submitted in Outline and form the Second Phase - “Outline Phases West”.

Development Plots N3, N2, N1 and S1 located in the east of the Site are submitted in Outline and form the third Phase – “Outline Phases East”.

The Application site has been subdivided into 10 Plots (N1, N2, N3, N3-E, N4, N5, N6, N7, S1 and S8). These are identified on Parameter Plan. 19066_X_(02)_102. The 10 plots sit within three indicative phases. Phase 1 covers the Detailed Proposals and is located at the centre of the Site. Phase 2 (also referred to as Outline Phases West) and Phase 3 (also referred to as Outline Phases East) form the Outline Proposals.

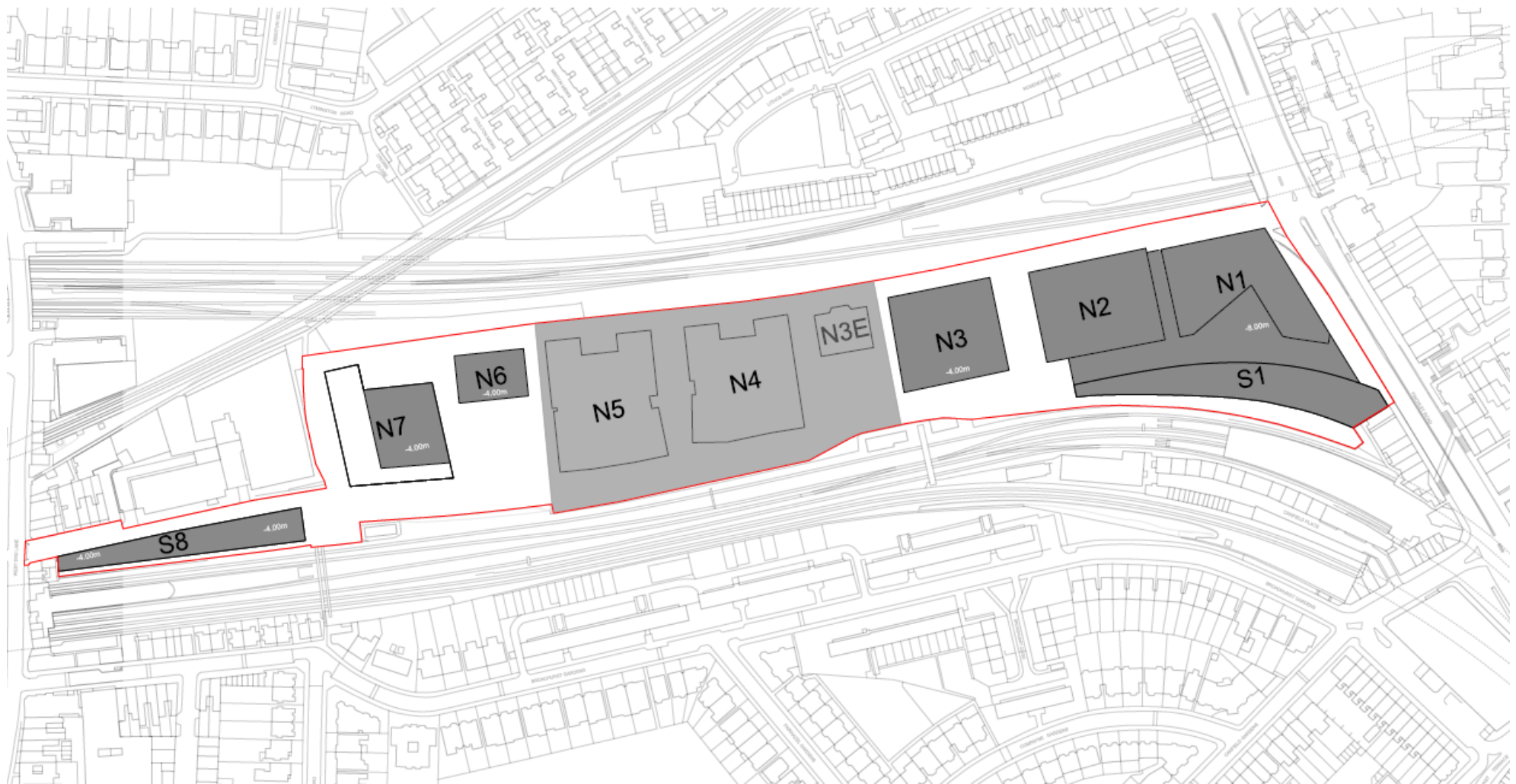

Figure 1 Plot Locations

2.1 Detailed Plots

Two of the three buildings that form part of the detailed planning application, specifically N4 and N5, will include localised basements within their proposed footprints, as shown in Figure 2. These are required in order to provide the space needed for the water tanks serving the two buildings. The proposed buildings will be of in-situ RC frame construction, with the basement areas constructed within an open excavation.



Figure 2 Extent of Proposed Basements for Buildings N4 & N5

2.2 Outline Plots

The basement proposals for the plots included in the outline application are presented in the parameter plan 19066_X_(02)_105-Proposed Basement Extents. This shows a maximum allowance that could be considered when the design of these plots will be developed in more detail.

One of the areas considered in the outline application is currently occupied by the existing O2 Centre. This is an existing 2-storey shopping centre located on Finchley Road. It was completed and opened in 1998. Within the building's footprint, there is also an existing half basement with retaining walls on the north and eastern elevations. There is also a full sided basement, however this only covers a small, localised area of the building's footprint (see Figure 3). At the time of writing this report, the proposal was for the internal half basement structure to be demolished, but leaving the perimeter retaining walls, parts of the base slab and the smaller localised basement intact. Consideration is also being given to lowering the base slab by 1.0m to provide additional headroom for delivery vehicles. This would only be required in the proposed car parking area and therefore has no impact on the existing perimeter retaining walls. The current elevation of Finchley road is 55m AoD and the existing basement extends to 48m AoD (see Figure 3). The proposed basement extents would make the total depth of the basement 8m below the level of Finchley Road.



Figure 3 Existing O2 Basement Structure

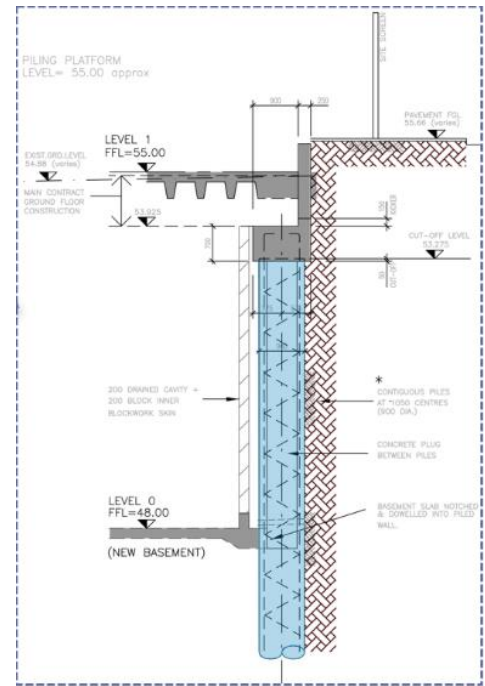

3 The Site

3.1 Location

The Site is located in Finchley, within the London Borough of Camden (LBC). It is bounded by Blackburn Road, which envelops the Site along its southern and northern edge, also extending to the west. Finchley Road (A41) bounds the Site to the east, with Billy Fury Way to the west. The Thameslink Bedford-Brighton railway line runs along the northern edge of the Site, and the London Underground Jubilee and Metropolitan lines run above ground along the southern edge of the Site.

The Site is approximately 5.7 ha in size and currently comprises the O2 Centre, which is arranged over three floors and contains a cinema, a mix of retail units, restaurants and cafes, a health club, a community room and a Sainsbury's store; hard-standing, which is used as a car-park with space for 520 vehicles and a Homebase store, and to the western part of the Site are two purpose-built car showrooms and a builder's merchant.

The land contained within the red line plan comprises the following:

- O2 Centre;
- Associated O2 Centre car park;
- Homebase store;
- Car showrooms; and
- Builder's merchant.

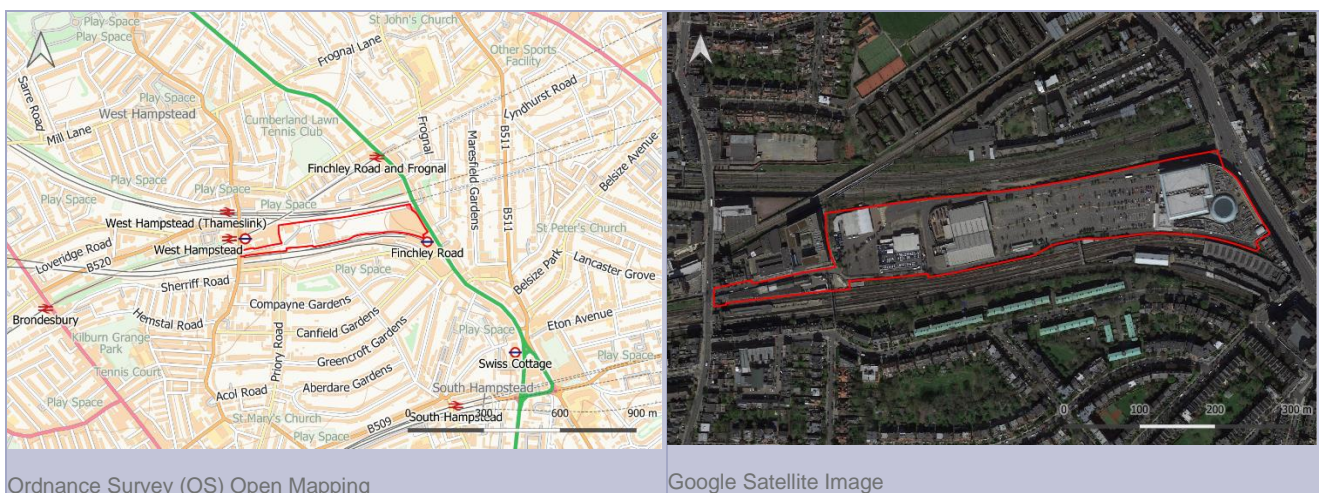

Figure 4 Site Location

3.2 Geotechnical features

3.2.1 Within the site boundary

The following structures and features lie within the site boundary of the O2 Finchley Road scheme:

- Existing O2 Finchley shopping centre with associated foundations and basement
- Thames Water storm drain and associated buried sewage tunnel at 18m depth (see figure 1 for location)
- Three existing buildings to the west of the site, currently occupies by Homebase, Volkswagen and Audi.
- Builder's depot in the southwestern section of the site

3.2.2 Outside the site boundary

- Thameslink railway land to the north
- Metropolitan and Jubilee lines to the south

- Retaining wall structure lining the boundary between Blackburn Road and the Thameslink railway, reaching up to 5m retained height at the intersection with Finchley Road (A41)
- Bridge structure to the northeast of the site allowing Finchley Road to span over the Thameslink railway lines.
- Bridge structure to the northwest of the site featuring a footbridge and overground train line passing over the Thameslink railway lines.
- 9 storey residential building adjacent to the western site boundary

3.3 Third Party Assets

This section will discuss the third party assets within close proximity to the site boundary which may be affected by the installation of basements on the site.

3.3.1 Railway Assets

The land to the north and to the south of the site is currently occupied by railway infrastructure. For that reason, the distance of the proposed basement to the railway infrastructure has been determined and is presented in Table 1

Table 1 Proximity of railway assets

Plot	Distance from railway (m)	Closest railway (north/south)
N1 (outline plot)	20	North
N2 (outline plot)	19	North
N3 (outline plot)	21	North
N4 (detailed plot)	26	North
N5 (detailed plot)	25	North
N6 (outline plot)	27	North
N7 (outline plot)	38	South
S1 (outline plot)	11	South
S8 (outline plot)	7	South

3.3.2 Buildings

From the proposed site layout the only potential impact on surrounding buildings is associated with outline plot S8 (see Figure 5). At this location, the proposed basement could extend up to the boundary of the site which is adjacent to small commercial units immediately adjacent to the west, railway tracks 7m to the south and a building 12m to the north. As a consequence, all this infrastructure lies within the potential zone of influence of basement excavation works.

As part of the S8 plot development a detailed basement impact assessment shall therefore be undertaken. With an appropriate construction methodology as discussed in section 5, building damage will be restricted to category 1 or less.



Figure 5 Adjacent infrastructure to plot S8

4 Ground Conditions

4.1 Soil conditions

The published geology of the area is shown on the geological map for North London (Sheet 256), scale 1:50,000), published by the British Geological Survey (BGS), see **Error! Reference source not found.** Derivatives of the BGS mapping are included in the Geology Report (Landmark) presented in the Pell Frischmann desk study, and further geological information has also been obtained from the BGS website. This mapping does not record any superficial deposits over the site and indicates the bedrock of the London Clay Formation present over the whole site area.

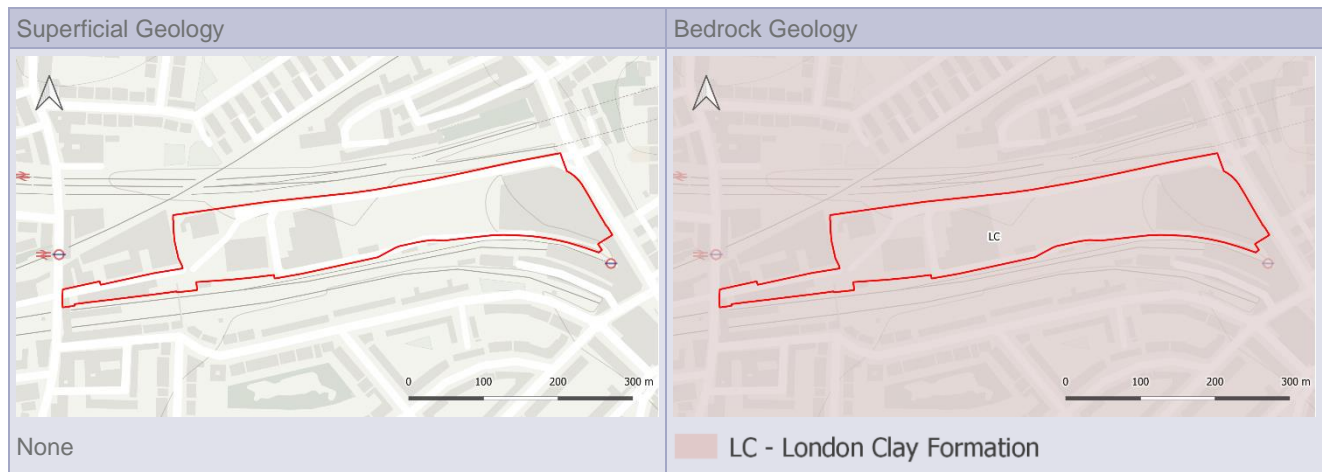

Figure 6 Published Geology

An intrusive investigation has been completed by RSK Ltd. and a factual report has been issued. The borehole logs confirm the presence of the London Clay and record variable thickness of Made Ground across the site. **Error! Reference source not found.** below presents a summary of the ground encountered at the site.

Table 2 Summary of stratigraphical succession

Stratum	Thickness (m)	Description
Made Ground	0.5 – 2.0	Dark greyish brown locally black silty sandy. Sand is fine to coarse. Gravel is angular to sub-rounded fine to coarse of concrete, flint, brick and mortar with occasional fragments of ceramic pottery.
London Clay	> 60m	Grey CLAY with fine selenite crystals, occasional claystone / mudstone and sand bands. Becoming sandier towards the base of the strata.

The closest borehole (BH05) to the O2 Centre located at the western end of the carpark area recorded a thickness of Made Ground of 0.8m.

4.2 Groundwater and Hydrology

There are no surface water features within 1 km of the site. A former 'lost river' of London, assumed to be a tributary of the Westbourne stream may cross the site in the vicinity of the O2 Centre, although it is understood that this is likely is now a sewer.

No groundwater was recorded in the borehole records from the recent RSK investigation. The London Clay present at shallow depth below the Made Ground is an impermeable unproductive stratum defined as having negligible significance for water supply or baseflow to rivers, lakes and wetlands. Consequently, the only ground water that is likely to be present on site will be that associated with pockets of locally perched water within the Made Ground.

5 Outline Construction Methodology

Two different methodologies will be discussed in this section for the construction of new basements both with and without site constraints at the perimeter of the excavation. It should be noted that a detailed construction method statement will be produced in due course by the Contractor.

5.1 No Site Constraints Methodology

In areas where the site layout allows for the basement excavation works to be undertaken with battered slopes, the following methodology is appropriate for single storey basement installation:

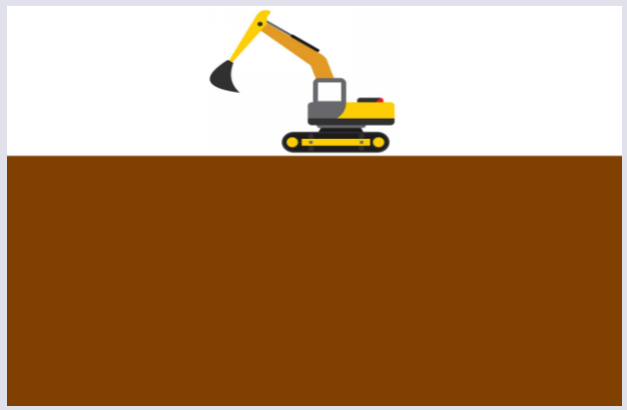
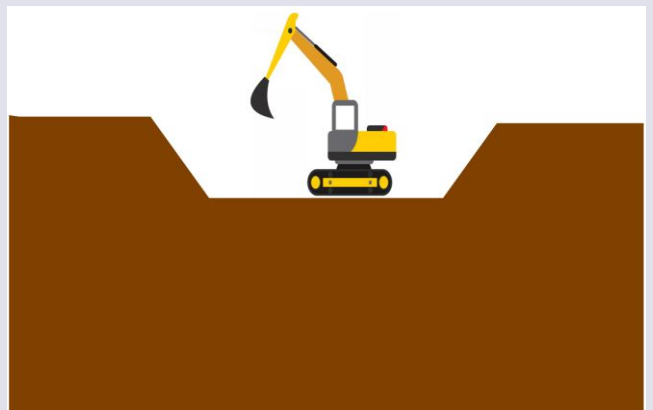
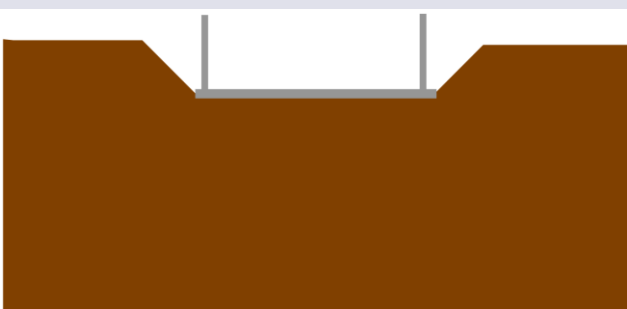
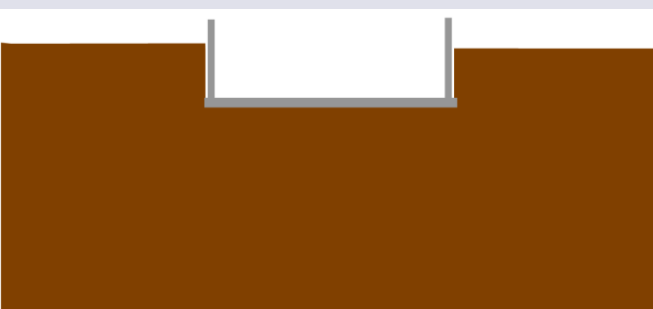
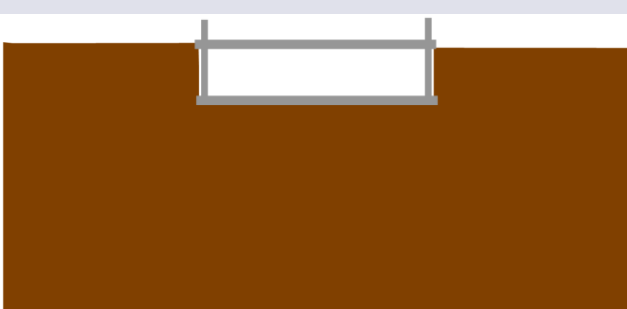
Table 3 Battered slopes excavation	
	
1- Initial conditions	2- Battered excavation of basement (1V:2H slopes)
	
3- Construction of basement slab and basement walls	4- Backfilling of excavation to ground level behind walls
	<p>Note: Stage 4 (backfilling) can be undertaken with the walls supported by raking props or by the casting the ground floor prior to backfilling. In this case the walls would be designed as propped cantilevers.</p>
5- Construction of ground floor slab	

5.2 Methodology With Site Constrains

Some proposed basement locations do not offer the possibility of excavating using battered slopes due to adjacent infrastructure or services, therefore a bottom-up sequencing of works can be considered as shown below. It should be noted that for the single storey basements currently proposed an intermediate temporary prop would not be required.

Table 4 Bottom-Up Construction Method - Simplified

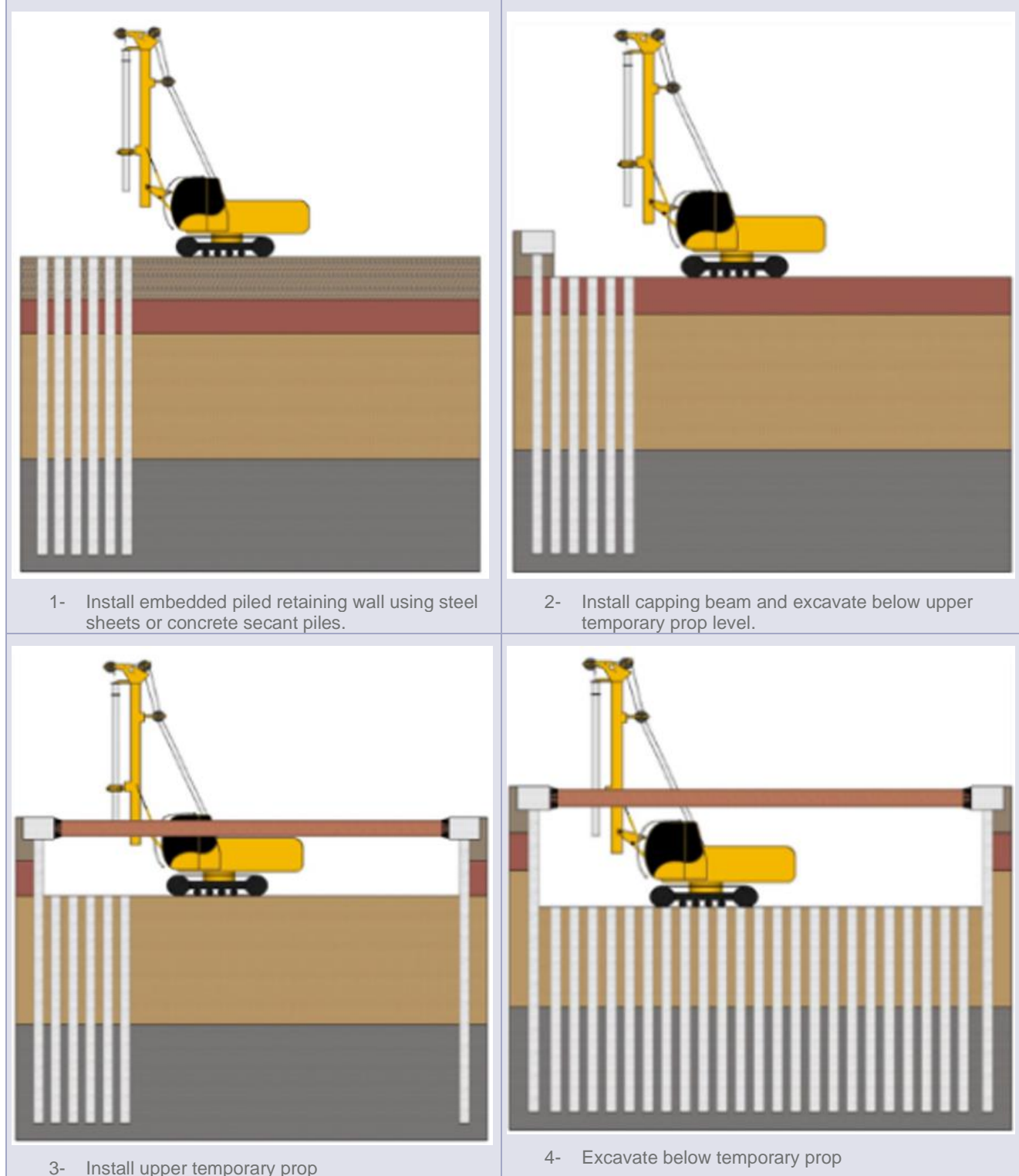

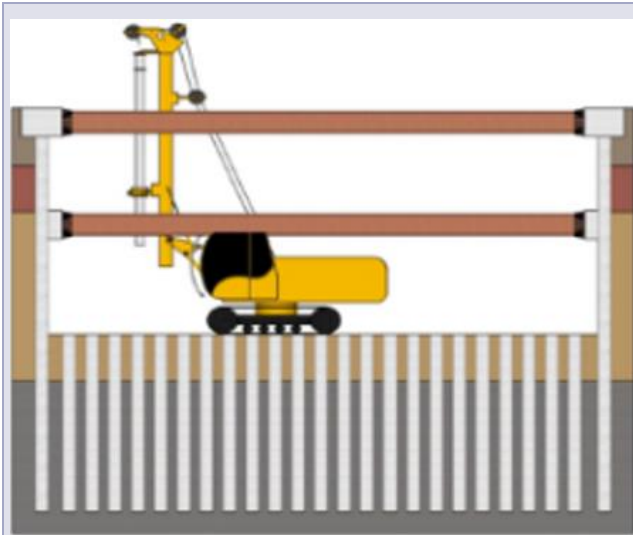

5- Install additional props if required.



6- Install base slab followed by intermediate floor followed by removal of intermediate temporary prop.

6 Screening

In order to establish the key elements of the BIA that are required, a screening process has been carried out on the proposed development. This process consists of posing a series of questions within a screening flowchart covering the following areas; groundwater flow; land stability; and surface water flow. The questions used below are derived from the flow charts presented in the Camden Planning Guidance: Basements, and are presented in tabular form in the following sections.

6.1 Groundwater Flow

Question	Site specific response
1a. Is the site located directly above an aquifer?	No. The site is underlain by London Clay, an unproductive stratum.
1b. Will the proposed basement extend beneath the water table surface?	Yes. During site investigations, a perched groundwater table was generally present. No deep water table (within the London Clay to the depth of the BHs) was encountered. Refer to RSK site investigation Nov 2021.
2. Is the site within 100m of a watercourse, well (used/disused) or potential spring line?	Yes. It is possible that a 'lost river' associated with the Westbourne stream is within 100m of the basement.
3. Will the proposed basement development result in a change in the proportion of hard surfaced / paved areas?	No. The current area of hardstanding is approximately the same as the proposed area of hardstanding. It is noted that new structures are to be constructed within the current hard-standing car parking area. Any increase in impermeable area and drainage requirements shall be considered in the drainage strategy (ref: 104878-PEF-ZZ-ZZ-RP-D-100017).
4. As part of the site drainage, will more surface water (e.g. rainfall and run-off) than present be discharged to the ground (e.g. via soakaways and / or SUDS)?	See above.
5. Is the lowest point of the excavation (allowing for any drainage and foundation space under the basement floor) close to or lower than, the mean water level in any local pond or spring line?	No

6.2 Ground Stability

Question	Site specific response
1. Does the site include slopes, natural or manmade greater than 7° degrees?	No
2. Will the proposed re-profiling and landscaping at the site change slopes at the property boundary to more than 7°?	No

3. Does the development neighbour land, including railway cuttings and the like, contain slopes greater than 7°?	Yes, there is a 5m retaining structure to the northeast of the site, outside the site boundary.
4. Is the site within a wider hillside setting in which the general slope is greater than 7°?	No
5. Is the London Clay the shallowest strata at the site?	No. The London Clay is overlain by made ground of varying thickness between 1-1.5m, locally up to 3.m thick.
6. Will any trees be felled as part of the proposed development and / or are any works proposed within any tree protection zones where trees are to be retained?	Yes, small trees are present on site as landscaping features.
7. Is there a history of seasonal shrink-swell subsidence in local area and / or evidence of such effects at the site?	No
8. Is the site within 100 m of a watercourse or potential spring line?	Yes
9. Is the site within an area of previously worked ground?	Yes, there is made ground overlying the London Clay which is approx. 1-1.5m thick, locally up to 3.m thick.
10. Is the site within an aquifer?	No
11. Is the site within 5m of a highway or pedestrian right of way?	Yes
12. Will the proposed basement significantly increase the differential depth of foundations relative to neighbouring properties?	No
13. Is the site over (or within the exclusion zone of) any tunnels, e.g. railway lines?	Yes.

6.3 Surface flow and flooding

Question	Site specific response
1. Is the site within the catchment of the pond chains on Hampstead Heath	No
2. As part of the proposed site drainage, will surface water flows (e.g. volume of rainfall and peak run-off) be materially changed from the existing route.	No
3. Will the proposed basement development result in a change in the proportion of hard surfaced / paved external areas.	No. The current area of hardstanding is approximately the same as the proposed area of hardstanding, see 6.1, item 3.
4. Will the proposed basement development result in changes to the profile of the inflows (instantaneous and long term) of surface water being received by adjacent properties or downstream watercourses.	No
5. Will the proposed basement result in changes to the quantity of surface water being received by adjacent properties or downstream watercourses.	No

<p>6. Is the site in an area identified to have surface water flood risk according to either the Local Flood Risk Management Strategy or the Strategic Flood Risk Assessment or is it at risk of flooding, for example because the proposed basement is below the static water level of a nearby surface water feature.</p>	<p>Yes. It is within an area known to be at risk of surface water flooding. See FRA for detailed assessment (ref: 104878-PEF-ZZ-ZZ-RP-D-100009)</p>
---	---

7 Scoping and Potential Impacts

The scoping stage identifies the potential impacts of the proposed scheme that have been shown by the screening process to need further investigation. The potential impacts of each of the matters of concern identified in the screening are identified. The conceptual ground model presented earlier in section **Error! Reference source not found.** together with the Desk Study is considered a suitable basis on which to assess the potential impacts.

The following potential impacts have been identified and will be further assessed in the following basement impact assessment.

7.1 Groundwater Flow

Potential Impact	Possible Consequence
2.The site is within 100 m of a watercourse or potential spring line.	A historic lost river/tributary of the Westbourne stream is likely to run as a culverted sewer within 100m of the site. Since the basement is already constructed there will not be any impact on the existing sewer.

7.2 Ground Stability

Potential Impact	Possible Consequence
3.The development neighbour land, including railway cuttings and the like, contains slopes greater than 7°	The existing retaining structure outside the site boundary is adjacent to the existing O2 Centre which already features appropriate measures. The works will not impact this existing boundary.
6.Trees will be felled as part of the proposed development	Removal of the small landscaping trees will have no impact on ground stability
8. The site is within 100 m of a watercourse or potential spring line	A historic lost river/tributary of the Westbourne stream is likely to run as a culverted sewer within 100m of the site. Since the basement is already constructed there will not be any impact on the existing sewer.
9.The site is within an area of previously worked ground	Some infilled shallow basements might be present but are of no significance to ground stability.
11.The site within 5 m of a highway or pedestrian right of way.	Damage and settlement to adjacent infrastructure may occur as the result of ground movements associated with construction activities.
13.The site is over (or within the exclusion zone of) tunnels and railway lines.	The site is adjacent to NR rail track with some minor incursion of the existing basement into the exclusion zone. It is noted that the local basement area under block N5 overlies an existing deep storm water relief sewer.

7.3 Surface flow and flooding

Potential Impact	Possible Consequence
6.The site is within an area known to be at risk of surface water flooding.	Potential flooding of the basement.

8 Basement Impact Assessment

8.1 Detailed Plots N4 and N5

As noted in section 2.1, the form of construction for the N4 and N5 blocks will be an in-situ concrete frame. A typical cross-section through the basement areas is shown in Figure 7, which shows a concrete box construction, formed of RC retaining walls and a suspended base slab supported on piled foundations. The basement box will be constructed monolithically with the rest of the ground floor slab and therefore act and move as a single frame.

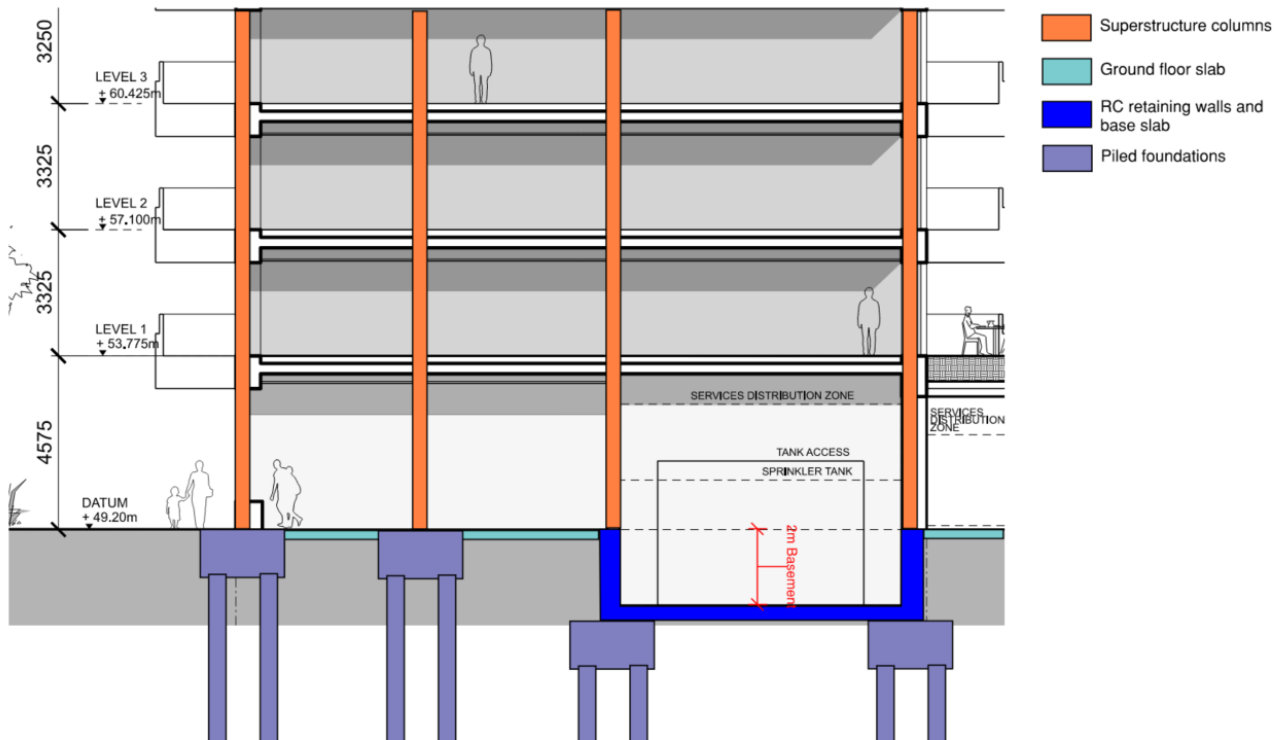

Figure 7 Typical cross-section through proposed basements of N4 and N5

Since the extent of the two proposed basements is relatively small in comparison with the footprints of the two buildings, it has been assumed that a simple open excavation will be possible. At the same time, the position of both basements is quite central in relation to the northern and southern boundaries and as a result the impact of the excavation on the adjacent Network Rail and TFL infrastructure assets will be minimal.

Underneath the proposed footprint of block N5, there is a storm relief sewer flowing from north to south, Thames Water reference 8704, running approximately 18m below the ground level, as shown in Figure 2. A formal application for a build-over agreement has been made with Thames Water and the proposed design has been approved in principle. Furthermore, an initial ground movement assessment was carried out for both the construction phase and the permanent condition of the development. This showed that the induced pressures and strains from the new development are within acceptable limits for the underling sewer. The formal sign-off from Thames Water of the build-over agreement is subject to the detailed design and final ground movement assessment.

8.2 Existing O2 Centre

It should be noted that this impact assessment refers to works being carried out to an existing basement rather than the excavation and construction of a new basement. As a consequence, ground movements due to excavation and construction of the original basement will have ceased and are not of concern. The proposed works will involve the demolition of the superstructure, the ground floor slab and internal basement walls, leaving the perimeter walls, base slab and bearing piles in place, refer to Figure 8.

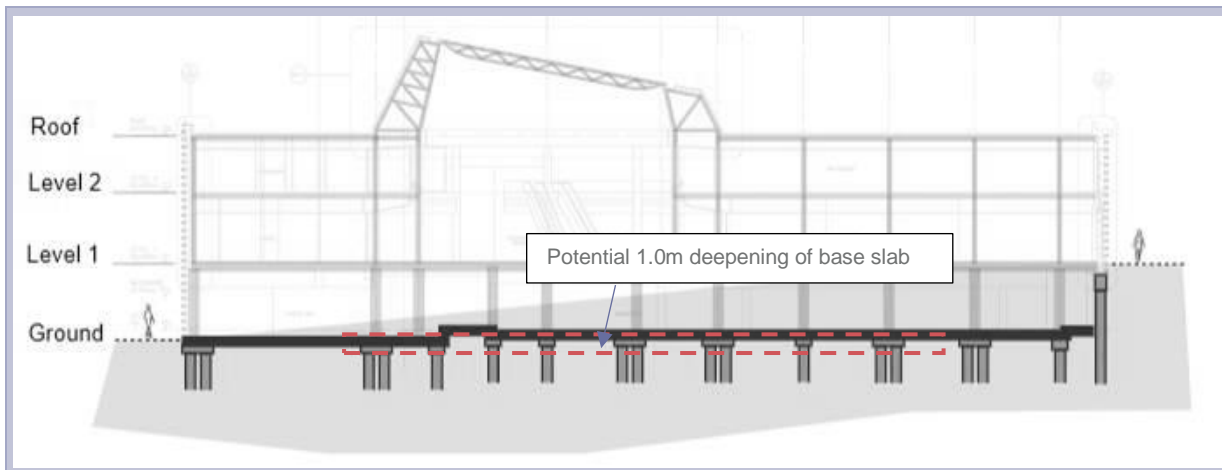

Figure 8 Cross-section through proposed scheme showing retained basement slab and walls

Based on the proposed works the following issues and their potential impact on adjacent infrastructure are addressed;

- Ground movement associated with demolition
- Loss of support to basement perimeter walls
- Ground movement from construction

8.2.1 Impact from demolition

The existing structure is supported on bearing piles extending from the basement level into the underlying London Clay. Demolition of the superstructure will result in unloading of the piles with some associated upward movement of the piles. This upward movement would be less than that associated with the original pile settlement under the action of the structural loads since the unloading response of the ground and pile is stiffer than the original loading response. Typically working settlements of 10-15 mm can be assumed for the original design, and an unloading response of 5-10mm (upwards) might be conservatively expected. Movement of this magnitude will have negligible impact on ground movement outside the basement footprint with no impact on adjacent infrastructure.

8.2.2 Loss of support to basement slab

The ground floor slab currently provides support to the basement walls in the permanent case. The 'for construction enabling works' drawings state "*Piling contractor to design contiguous pile walls to be free standing cantilever walls - above 47.60 and to accommodate cantilever retaining wall above*". Consequently, it can be assumed that, at least in the original temporary construction case, the contiguous piled wall which forms the existing basement would provide ground support. The proposed works may introduce a temporary undrained response of the soil, and consequently the existing basement wall would continue to provide adequate support. However, the removal of the ground floor slab may nevertheless lead to some inward deflection of the wall. It is thus proposed that temporary raking props are provided to brace the existing basement wall to the base slab prior to demolition of the exiting ground floor, and these props remain in place until completion of the new ground floor. This consecution sequence is illustrated in Figure 9 below which will mitigate any potential deflection of the existing basement wall resulting in negligible impact with respect to ground movements and adjacent infrastructure.

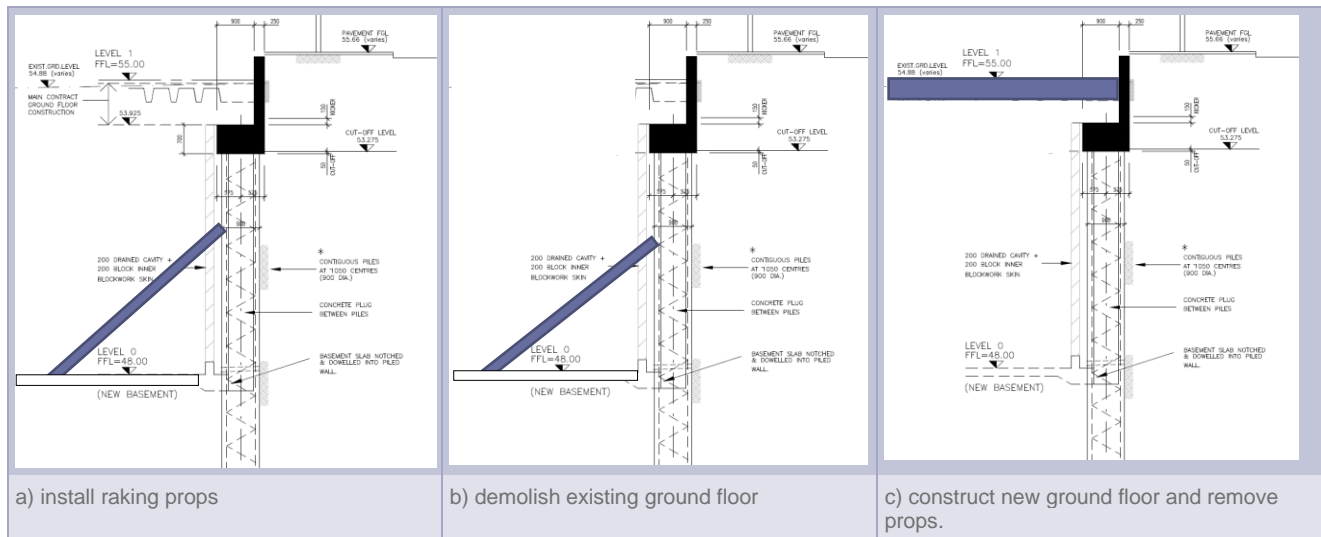

Figure 9 Support to existing basement walls during construction

8.2.3 Impact from construction

The loads imposed by the new structure shall be carried by existing bearing piles extending below the basement slab. As a consequence, the construction works will only introduce a degree of unloading and reloading of the basement piles and its integral slab, which as previously discussed will be small and will not result in any associated ground movement or impact on adjacent infrastructure.

8.3 Outline Plots

The proposed design for the rest of the plots within the outline application has not been developed in enough detail to determine the full extent of any new proposed basements. For the purpose of this application, a maximum allowance is shown on the parameter plan 19066_X_(02)_105-Proposed Basement Extents. In the first instance the potential impact of the development of these basement areas can be quantitatively evaluated through the application of the CIRIA C760 (2017) report entitled 'Guidance on embedded retaining wall design'. This document allows the prediction of ground movements resulting from the construction of basements utilising an embedded retaining wall to be evaluated through the use of empirical relationships. The ground movements can be estimated for the installation of the wall and the subsequent excavation. For the proposed maximum excavation depth of 4m, maximum horizontal and vertical ground movements occur immediately behind the wall and are estimated at 3.2 and 2.0mm respectively assuming a secant/sheet piled wall is used to retain the sides of the excavation. These ground movements reduce linearly to zero at a distance equal to 1.5 and 2 times the wall depth for the horizontal and vertical ground movements. Typically, this would be some 10 to 12m from the wall. It is noted that installation effects using a sheet pile wall can be ignored.

Ground movements associated with excavation can be derived from CIRIA C760 through plots of ground movement and distance from the wall normalised to the excavation depth. Assuming a well-supported wall (high stiffness) the maximum horizontal movement occurs immediately behind the wall and is estimated at 6mm, reducing linearly to zero at about 16m from the excavation. For the vertical ground movement, the maximum settlement occurs at a distance approximately half the excavation depth (2 m), and is estimated at 3.0 mm, reducing to zero some 14m from the wall. Consequently, maximum horizontal and vertical ground movements of 9 and 5mm respectively are estimated.

Based on the above it is apparent that any basement construction associated with the proposed buildings N3, N6 and N7 are likely to have a negligible impact on any adjacent NR or TFL infrastructure due to the distance to the excavation. For example, the distance to the nearest rail track from N6 and N3 is estimated at 27 to 21m which is greater than 4 times the excavation depth and hence beyond the influence of the excavation.

The proposed basement area for Building S8 is approximately 7m from the adjacent rail track, and as such the track lies within the potential influence zone of the excavation. However, conservatively assuming that ground movements would be approximately 50% of the maximum horizontal and vertical values estimated above, then these respective movements of 4.5 and 2.5mm are unlikely to have any significant impact on the railway infrastructure.

However, it should be noted that BIA will be updated for each individual plot to reflect the final design proposals at the reserved matters stage, and where required a detailed ground movement assessment shall be undertaken.

8.4 Other Considerations

8.4.1 Building Damage

As presented in the previous section the proposed basement works are considered to have a negligible effect with regard to any induced ground movement on adjacent infrastructure. Consequently, in terms of a damage classification the proposed works can be considered to induce Category 0 damage in accordance with the Burland Scale as presented in CPG: Basements (Figure 11).

8.4.2 Groundwater and Hydrology

As presented earlier in section **Error! Reference source not found., Error! Reference source not found.**, groundwater may only be present as perched water within Made Ground overlying the London Clay. As such it is not considered a flowing aquifer and would not be affected by the presence of a basement. Furthermore, the depth and extent of the existing basement of the O2 Centre is not changing and hence there will be no impact on the existing groundwater and hydrological conditions.

8.4.3 Surface Water and Flooding

The site is known to be at risk from flooding and reference to an evaluation of the flood risk associated with the site should be obtained from the Flood Risk Assessment Report (104878-PEF-ZZ-ZZ-RP-D-100009). Notwithstanding this, the proposed works to the existing and new basement areas will result in no change to the current site hydrogeology and hydrology and hence no change to the current flood risk.

Since the site is identified as one at risk from surface water flooding, then any basement will be at risk from the ingress of surface flood water and appropriate design and access requirements should be considered.

9 Residual Risks

With reference to the scoping of risks in section 7 and the BIA presented above, the residual risks are summarised in this section

9.1 Groundwater Flow

Potential Impact	Remaining Risk After Assessment
2.The site is within 100 m of a watercourse or potential spring line.	Very low to negligible

9.2 Ground Stability

Potential Impact	Remaining Risk After Assessment
3.The development neighbour land, including railway cuttings and the like, contains slopes greater than 7°	Very low to negligible
6.Trees will be felled as part of the proposed development	Very low to negligible
8. The site is within 100 m of a watercourse or potential spring line	Very low to negligible
9.The site is within an area of previously worked ground	Very low to negligible
11.The site within 5 m of a highway or pedestrian right of way.	Low The installation of basement structures on site will need to incorporate protection measures to minimise ground movement where highways or pedestrian rights of way are within the zone of influence of the works.
13.The site is over (or within the exclusion zone of) tunnels and railway lines.	Low Basement construction will incorporate measures to minimise ground movement on vulnerable assets.

9.3 Surface flow and flooding

Potential Impact	Remaining Risk After Assessment
6.The site is within an area known to be at risk of surface water flooding.	Potential flooding of the basement. Refer to flood risk assessment for further information (doc reference: 104878-PEF-ZZ-ZZ-RP-D-100009)

10 Conclusions and Recommendations

A Basement Impact Assessment has been undertaken using best practice methodology in accordance with Camden Planning Guidance: Basements (January 2021). An initial screening and scoping process was carried out to identify potential areas that may be impacted by the proposed basements within the redevelopment of the site, and these areas were then investigated to present an assessment of the impact of the works.

It is concluded that the proposed works for the detailed plots N4 and N5 and the existing basement of the O2 Centre, will not result in any specific issues relating to land or slope instability, detrimental effect on the local hydrogeology and hydrology of the site, nor to have any adverse impact on neighbouring infrastructure. Building damage resulting from ground movements are qualitatively assessed as Category 0.

It is however recommended that monitoring points are installed on the existing basement wall and /or levelling points on the adjacent roadways, to verify the anticipated negligible impact of the works on adjacent infrastructure. Similarly, for the construction of block N5 over the existing Thames Water sewer, a ground movement monitoring regime will be in place as part of the build-over agreement. It is noted that the impact of construction works on Thames Water infrastructure is the subject of a separate detailed assessment.

With regards to outline plots N3, N6 and N7, these are of sufficient distance from existing infrastructure that open excavations are likely to be feasible with negligible impact but if required, supported excavations will be undertaken. For plot S8, rail infrastructure to the south and existing buildings to the west and north lie within the zone of influence of basement works and a detailed ground movement and building damage assessment shall be undertaken as appropriate.

11 References

Pell Frischmann, Flood Risk Assessment, document reference 104878-PEF-ZZ-ZZ-RP-D-100009, dated January 2022.

Pell Frischmann, Land Contamination Desk Study, Preliminary Risk Assessment, document reference 104878-PEF-ZZ-XX-RP-GG-600002, dated January 2022.

CIRIA C580. Embedded Retaining Walls – Guidance for Economic Design. London, 2003.

London Borough of Camden. Camden Planning Guidance: Basements.

Arup. Guidance for Subterranean Development. 2010

Ball R, Langdon N, and M Creighton. "Prediction of party wall movements using CIRIA report C580". Ground Engineering, Sept 2014.

Appendix A Existing O2 Centre Drawings

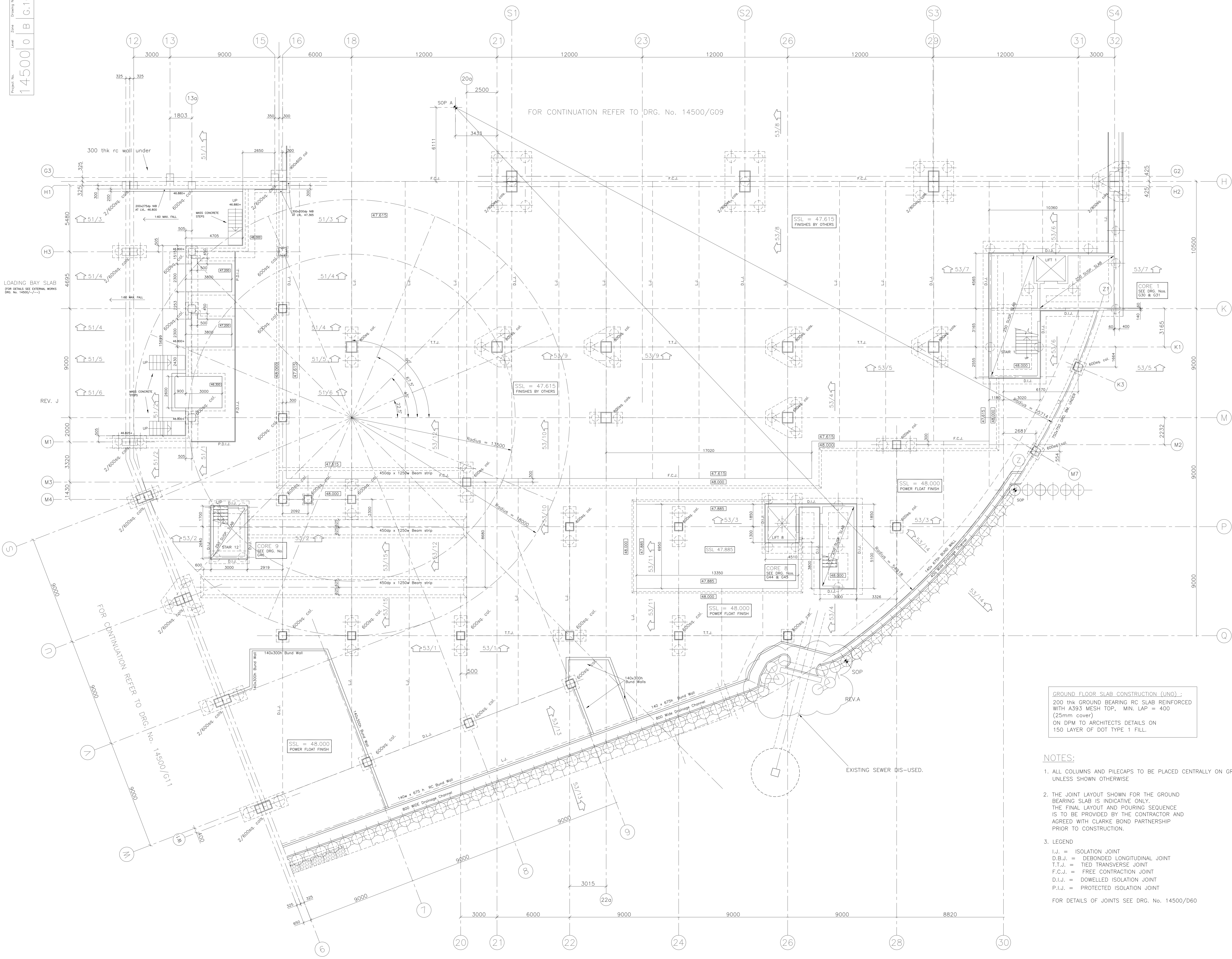

- Notes:
- Do not scale this drawing.
 - Contractor to check all dimensions and report all errors and omissions to the Engineer in writing.
 - Concrete mix to be given which shall conform in all respects with the requirements of the specifications.
 - Design loadings:-

KL/PL	KL/PL
KL/PL	KL/PL
KL/PL	KL/PL
 - Ground bearing resistance:- 100 KL/PL
 - Cover to reinforcement shall be:-
 - FOR CONCRETE MIXES SEE SPECIFICATION E10 : Clauses 132B, 133B & 135 (for columns)

Cost in situ:
 Mainwork to be tied to the concrete frame via cast in channels by HALFEN-UNISTRUT Type 53/7/8, 21, 133/1. Channels to be Brick and blockwork to be fixed to cast in channels with HALFEN-UNISTRUT HBT channel ties.
RC walls:
 For RC walls to be clad in masonry, (eg. core walls externally), provide stainless steel cast in channels of 450 vertically and 900 horizontal centres.
RC columns in external walls:
 Above stainless steel channels in one face and galvanized mild steel in two faces. All channels at 225 vertical centres.
RC columns within internal walls:
 Where on internal wall is built up to an RC column provide mild steel cast in channels of 225 vertical centres in the column faces.

Reinforcement schedules nos.

Scales: 1:100

Ref.	Detail.	By	Date.
A	GENERALLY UPDATED	BC	2.10.96
B	FURTHER DETAILS ADDED	BC	23.10.96
C	FURTHER DETAILS ADDED	BC	
D	PILE DIAMETERS AND PILE CAPS REVISSED	BC	31.12.96
E	SLAB JOINTS, LEVELS, SLAB STEPS - ADDED, CORE 8 REVISSED	BC	15.10.96
F	REVISIONS MARKED THIS	BC	19.12.96
G	COLUMNS ON GRID LINE W MOVED, RC BEAM WALLS ADDED, OTHER REVISIONS SHOWN CLOUDED	BC	14.1.97
H	SLAB STRENGTHENING STRIPS ADDED, RC BEAM OTHER WORK REVISIONS ISSUED AS WORKING DRAWING	BC	18.1.97
J	CORE SETTING OUT AMENDED, REVISIONS SHOWN CLOUDED	BC	18.1.97
K	COLUMNS ON GRID W/7 & 8 MOVED, LOADING DOCK AREA, DOCK LEVELLERS REVISSED	BC	15.5.97
L	MINOR AMENDMENTS	BC	18.5.97
M	MINOR AMENDMENTS	BC	

Revisions

Ref.	Detail.	By	Date.
A	GENERALLY UPDATED	BC	2.10.96
B	FURTHER DETAILS ADDED	BC	23.10.96
C	FURTHER DETAILS ADDED	BC	
D	PILE DIAMETERS AND PILE CAPS REVISSED	BC	31.12.96
E	SLAB JOINTS, LEVELS, SLAB STEPS - ADDED, CORE 8 REVISSED	BC	15.10.96
F	REVISIONS MARKED THIS	BC	19.12.96
G	COLUMNS ON GRID LINE W MOVED, RC BEAM WALLS ADDED, OTHER REVISIONS SHOWN CLOUDED	BC	14.1.97
H	SLAB STRENGTHENING STRIPS ADDED, RC BEAM OTHER WORK REVISIONS ISSUED AS WORKING DRAWING	BC	18.1.97
J	CORE SETTING OUT AMENDED, REVISIONS SHOWN CLOUDED	BC	18.1.97
K	COLUMNS ON GRID W/7 & 8 MOVED, LOADING DOCK AREA, DOCK LEVELLERS REVISSED	BC	15.5.97
L	MINOR AMENDMENTS	BC	18.5.97
M	MINOR AMENDMENTS	BC	

Client: BURFORD GROUP PLC
 Project: LONDON: FINCHLEY ROAD DEVELOPMENT
 Description: LEVEL 0 GROUND FLOOR C.A. ZONE B

WORKING DRAWING

CONSULTING ENGINEERS
 BIRMINGHAM 0121 414 1989
 BRISTOL 0117 929 2244
 CARDIFF 01222 810785
 EXETER 01392 831861
 LONDON 0171 255 1998
 MANCHESTER 0161 962 2974
 WAKEFIELD 01924 823773

CLARKE BOND PARTNERSHIP

GROUND FLOOR SLAB CONSTRUCTION (UNO) :
 200 thk GROUND BEARING RC SLAB REINFORCED WITH A393 MESH TOP, MIN. LAP = 400 (25mm cover) ON DPM TO ARCHITECTS DETAILS ON 150 LAYER OF DOT TYPE 1 FILL.

- NOTES:**
- ALL COLUMNS AND PILECAPS TO BE PLACED CENTRALLY ON GRIDS UNLESS SHOWN OTHERWISE
 - THE JOINT LAYOUT SHOWN FOR THE GROUND BEARING SLAB IS INDICATIVE ONLY. THE FINAL LAYOUT AND POURING SEQUENCE IS TO BE PROVIDED BY THE CONTRACTOR AND AGREED WITH CLARKE BOND PARTNERSHIP PRIOR TO CONSTRUCTION.
 - LEGEND
 I.J. = ISOLATION JOINT
 D.B.J. = DEBONDED LONGITUDINAL JOINT
 T.T.J. = TIED TRANSVERSE JOINT
 F.C.J. = FREE CONTRACTION JOINT
 D.J. = DOWELED ISOLATION JOINT
 P.I.J. = PROTECTED ISOLATION JOINT
- FOR DETAILS OF JOINTS SEE DRG. No. 14500/D60

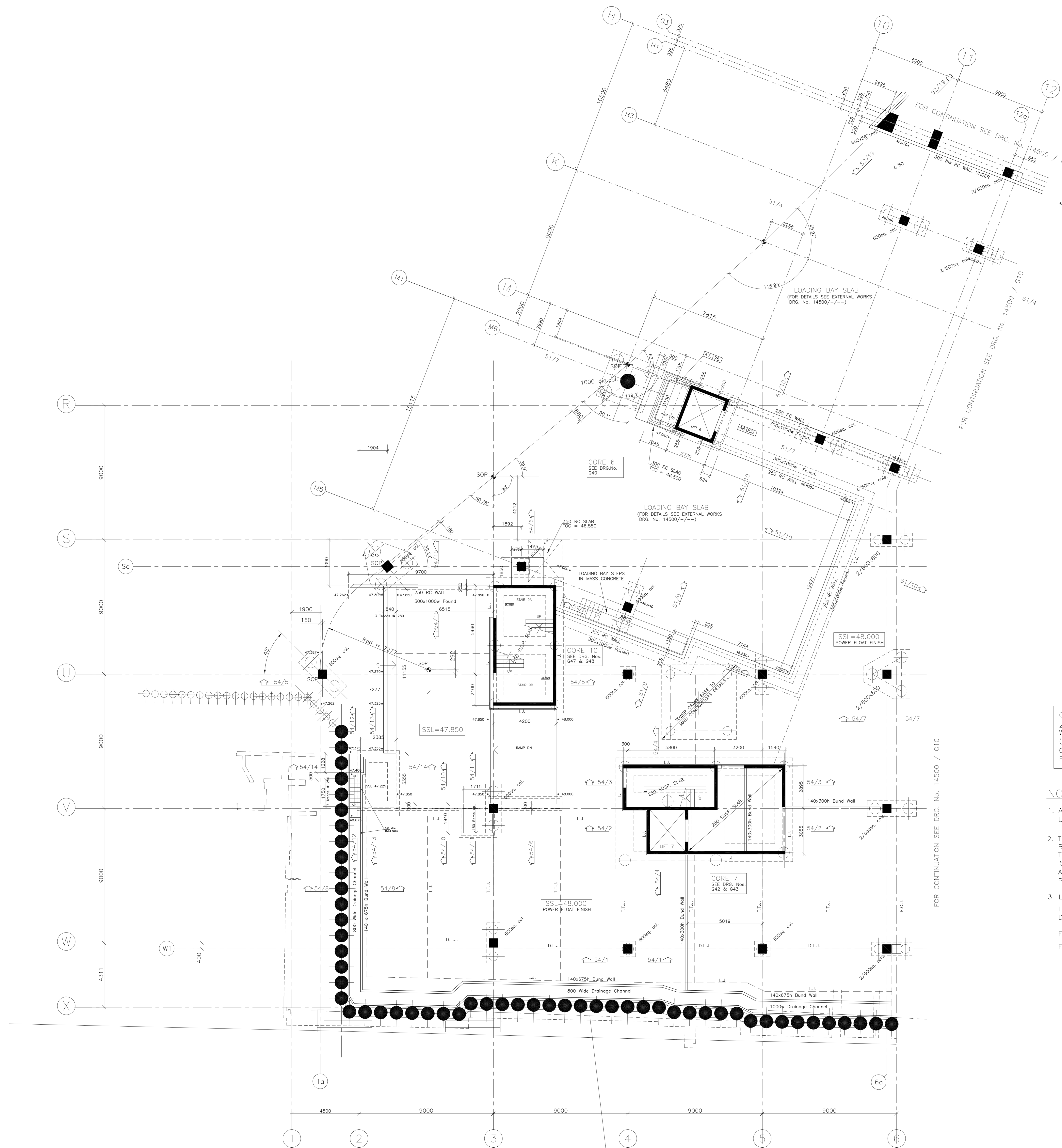

GROUND FLOOR SLAB CONSTRUCTION (UNO) :
 200 THK GROUND BEARING SLAB REINFORCED
 WITH A393 MESH TOP, MIN. LAP = 400
 (25mm cover)
 ON DPM TO ARCHITECTS DETAILS ON SAND
 BLINDING ON 150 LAYER OF DOT TYPE 1 FILL.

NOTES:

- ALL COLUMNS AND PILECAPS TO BE PLACED CENTRALLY ON GRIDS UNLESS SHOWN OTHERWISE
- THE JOINT LAYOUT SHOWN FOR THE GROUND BEARING SLAB IS INDICATIVE ONLY. THE FINAL LAYOUT AND POURING SEQUENCE IS TO BE PROVIDED BY THE CONTRACTOR AND AGREED WITH CLARKE BOND PARTNERSHIP PRIOR TO CONSTRUCTION.
- LEGEND
 I.J. = ISOLATION JOINT
 D.B.J. = DEBONDED LONGITUDINAL JOINT
 T.T.J. = TIED TRANSVERSE JOINT
 F.C.J. = FREE CONTRACTION JOINT
 FOR DETAILS OF JOINTS SEE DRG. No. 14500/G60

CONTIGUOUS PILED WALL
 BY OTHERS.
 SEE DRG. Nos. F52, F56 & F57

Notes:

- Do not scale this drawing
- Contractor to check all dimensions and report all errors and omissions to the Engineer.
- Concrete mix to be given which shall conform in all respects with the requirements of our specifications
- Design loadings -
- Ground bearing resistance - 100 kN/m²
- Cover to reinforcement shall be -

Cast in channels:
 Masonry to be tied to the concrete frame via cast in channels by HALFEN-UNISTRUT (Type G27.21, 21, 1321). Channels to be 300mm deep and 100mm wide. Brick and blockwork to be fixed to cast in channels with HALFEN-UNISTRUT HIT channel ties.
RC walls:
 For RC walls to be clad in masonry, (eg. core walls externally), provide stainless steel cast in channels at 450 vertically and 900 horizontal centres.
RC columns in external walls:
 Allow stainless steel channels in one face and galvanneal mild steel in two faces.
 All channels at 225 vertical centres.
RC columns within internal walls:
 Where an internal wall is built up to an RC column allow mild steel cast in channels at 225 vertical centres in the column faces.

Reinforcement schedules nos.

Scale: 1:100

Ref.	Detail.	By	Date.
A	GENERALLY UPDATED	RJD	2.10.96
B	FURTHER DETAILS ADDED	RJD	23.09.96
C	PILECAPS ADDED	RJD	-
D	-	-	-
E	FILE CAP CORE 7 REVISED, SLAB JOINTS ADDED	BC	10.12.96
F	REVISIONS MARKED THIS	BC	20.10.96
G	COLUMNS ON GRID LINE W MOVED	BC	14.03.97
H	RC BUND WALLS ADDED OTHER REVISIONS SHOWN CLOUDED	BC	18.4.97
I	OTHER REVISIONS SHOWN CLOUDED	BC	18.4.97
J	GENERALLY UPDATED, LEVELS AND NEW SECTION MARKS ADDED	BC	30.4.97
K	BUND WALL ADDED BETWEEN GRIDS A & B, WALL AND GRID LINE S4 & OIL STORAGE TANK AREA AMENDED PLUS MINOR REVISIONS	BC	14.03.97
L	-	RJD	14.03.97

Client: BURFORD GROUP PLC
 Project: LONDON: FINCHLEY ROAD DEVELOPMENT
 Description: LEVEL 0 GROUND FLOOR C.A. ZONE C
 WORKING DRAWING

CONSULTING ENGINEERS
 BIRMINGHAM 0121 414 1999
 BRISTOL 0117 929 2244
 CARDIFF 01222 810785
 EXETER 01392 831861
 LONDON 0171 255 1998
 MANCHESTER 0161 962 2974
 WAKEFIELD 01924 823773

CLARKE BOND PARTNERSHIP

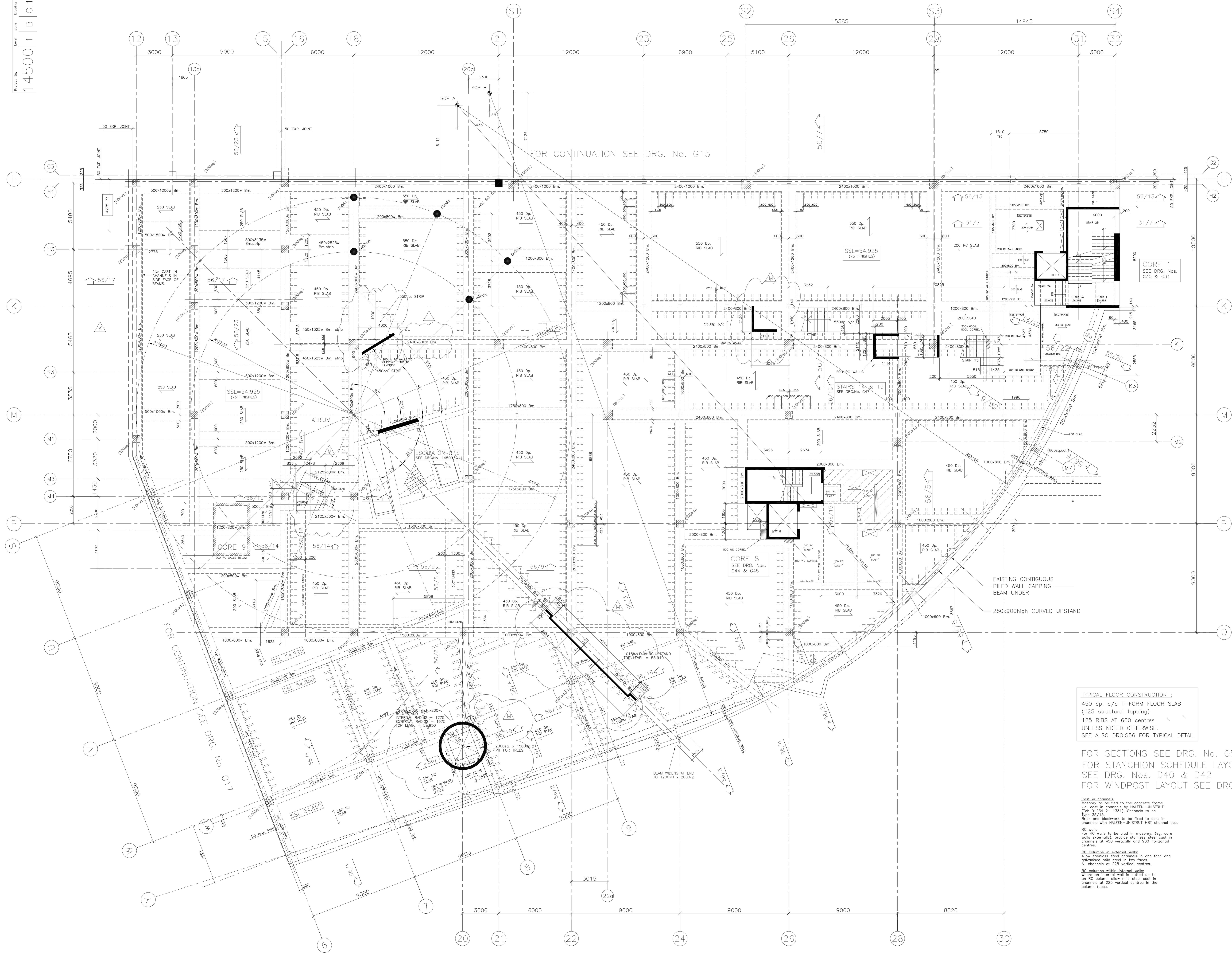

Notes:
1. See not scale this drawing.
2. Contractor to check all dimensions and report all errors and omissions to the Engineer.
3. Concrete mix to be grade which shall conform in all respects with the requirements of our specifications. SEE NOTE 7 BELOW.
4. Design loadings:-
5. Ground bearing resistance:-
6. Cover to reinforcement shall be:-
7. FOR CONCRETE MIXES SEE SPECIFICATION E10 : Clauses 132b, 133a & 133f (for columns)

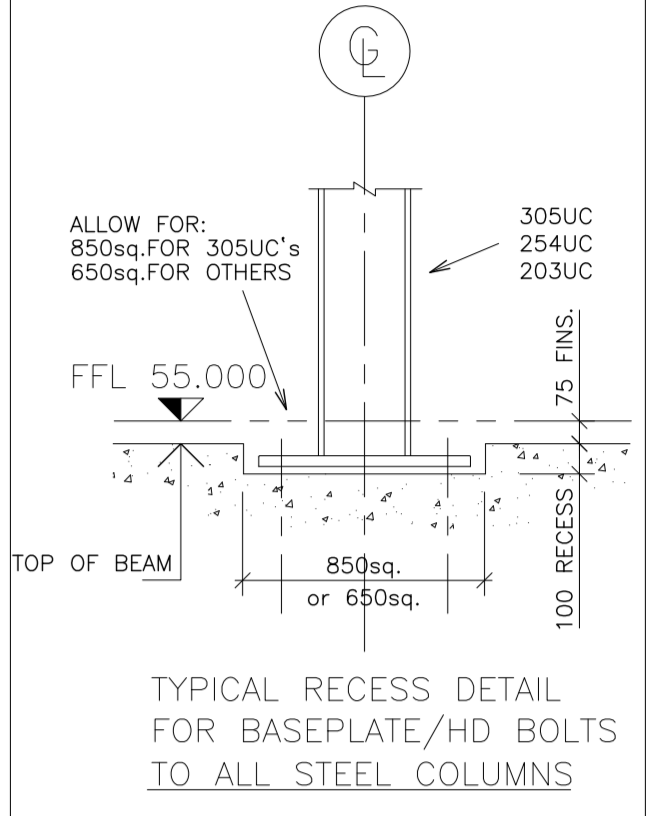

Reinforcement schedules nos.

Scales
1:100

Revisions	Ref.	Detail	By	Date
A	GENERAL	GENERAL	EC	21.10.96
B	GENERAL	GENERAL	EC	23.10.96
C	CONTIGUOUS	CONTIGUOUS PILED WALL ADDED, ESC. PIT REVISIONS, CORE B WALL ADDED, ALL CORES AMENDED TO BRICK/BLK, ALL OTHER REVISIONS CLOUSED, FIRST LAYOUT DLS ADDED	EC	4.12.96
D	CONTIGUOUS	CONTIGUOUS PILED WALL ADDED, ESC. PIT REVISIONS, CORE B WALL ADDED, ALL CORES AMENDED TO BRICK/BLK, ALL OTHER REVISIONS CLOUSED, FIRST LAYOUT DLS ADDED	EC	20.12.96
E	STATION	STATION AND RL BEAM ADDED, ELEMENTS REVISIONS, REVISIONS TO SIZES & WEIGHTS TO STAIRS, REMOVED SEE REV. 10/97	EC	5.4.97
F	FLOOR	FLOOR SLAB REVISIONS BETWEEN GRIDS 6-9/97-10/97 TO SORT FINISHED LEVELS, BEAM SIZES AMENDED BETWEEN GRIDS 12-14/97 FROM DUE TO HEADROOM PLUS REVISIONS	EC	14.3.97
G	STAIR	STAIR CORES 1 & 8 UPGRADED BEAM & SECTION BEAM FROM ELEVATION, REVISIONS TO STAIR CONSTRUCTION, REVISIONS TO STAIR CONSTRUCTION	DRB	21.5.97
H	ESCALATOR	ESCALATOR REVISIONS REVISIONS AMENDED	DRB	4.5.97
J	ESCALATOR	ESCALATOR REVISIONS REVISIONS AMENDED	EC	27.6.97
K	STAIR	STAIR CORE 1 & 8 UPGRADED BEAM & SECTION BEAM FROM ELEVATION, REVISIONS TO STAIR CONSTRUCTION, REVISIONS TO STAIR CONSTRUCTION	EC	4.8.97
L	BEAM	BEAM ON GRID W1 MOVED TO GRID W2, REVISIONS AMENDED	EC	28.8.97
M	SUPPORT	SUPPORT WALLS FOR STAIR 14 ADDED, LOCAL RAIL ADDED, ATRIUM LIFT DOL SETTING ADDED, BEAM ADDED, REVISIONS CLOUSED (ISSUED BY TRG)	EC	23.12.97
		REVISIONS AMENDED	EC	18.1.98

TYPICAL FLOOR CONSTRUCTION:
450 dp. o/a T-FORM FLOOR SLAB
(125 structural topping)
125 RIBS AT 600 centres
UNLESS NOTED OTHERWISE,
SEE ALSO DRG.G56 FOR TYPICAL DETAIL

FOR SECTIONS SEE DRG. No. G56
FOR STATIONING SCHEDULE LAYOUT
SEE DRG. Nos. D40 & D42
FOR WINDPOST LAYOUT SEE DRG. No. D28

Cast in channels:
Masonry to be tied to the concrete frame via cast in channels by HALFEN-UNISTRUT (Tel: 01234 211331). Channels to be type 35/15.
Brick and blockwork to be fixed to cast in channels with HALFEN-UNISTRUT HBT channel ties.
RC walls:
For RC walls to be clad in masonry, (eg. core walls externally), provide stainless steel cast in channels at 450 vertically and 900 horizontal centres.
RC columns in external walls:
Allow stainless steel channels in one face and galvanneal mild steel in two faces.
All channels at 225 vertical centres.
RC columns within internal walls:
Where an internal wall is built up to an RC column allow mild steel cast in channels at 225 vertical centres in the column faces.

Client: BURFORD GROUP PLC
Project: LONDON: FINCHLEY ROAD DEVELOPMENT
Description: LEVEL 1 FIRST FLOOR C.A. ZONE B
WORKING DRAWING

CONSULTING ENGINEERS
BIRMINGHAM 0121 414 1999
BRISTOL 0117 929 2244
CARDIFF 01222 810785
EXETER 01392 831861
LONDON 0171 255 1998
MANCHESTER 0161 962 2974
WAKEFIELD 01924 823772

CLARKE BOND PARTNERSHIP

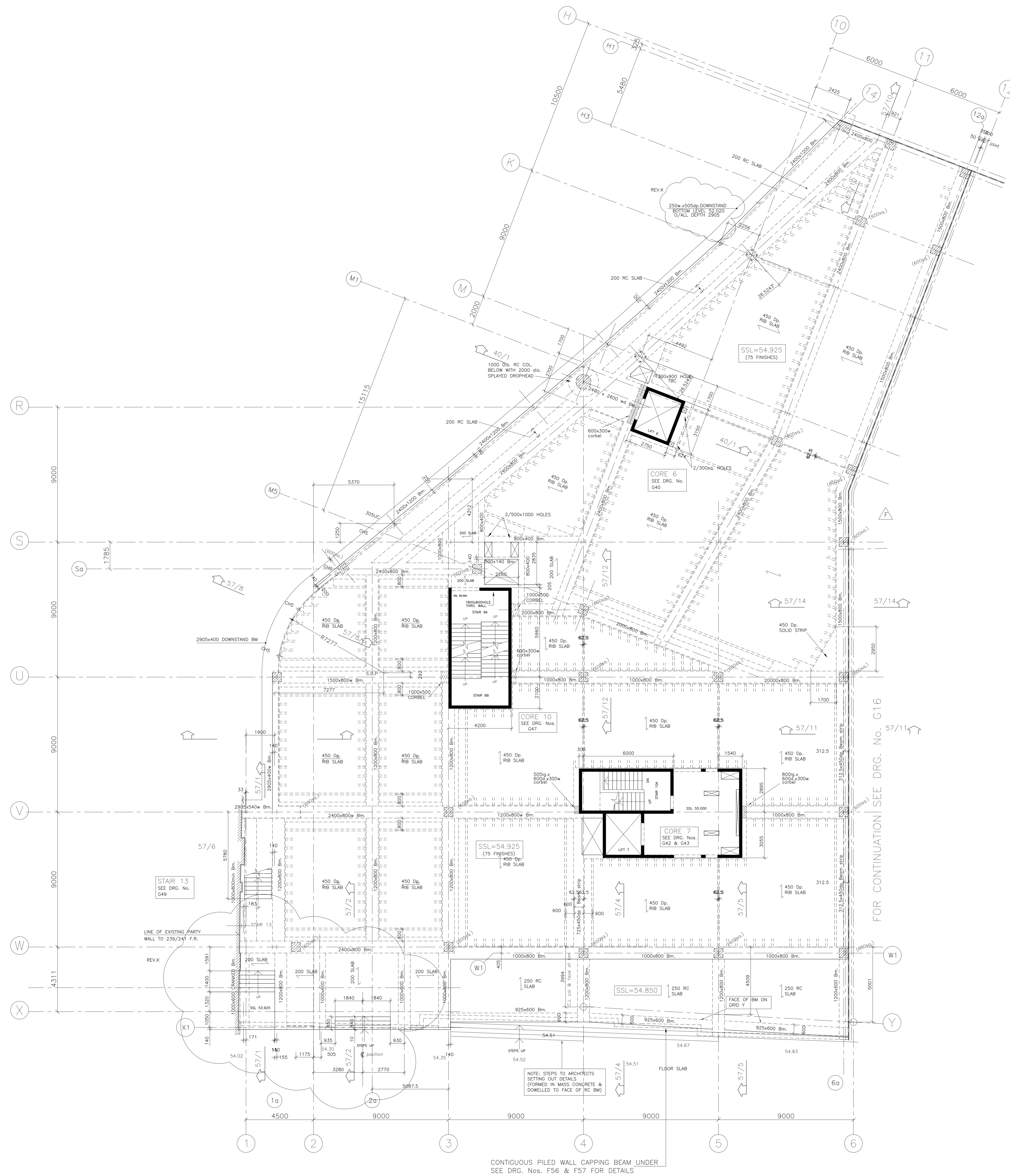

TYPICAL FLOOR CONSTRUCTION :
 450 dp. o/a T-FORM FLOOR SLAB
 (125 structural topping)
 125 RIBS AT 600 c/c
 UNLESS NOTED OTHERWISE
 SEE ALSO DRG. No. G57 FOR TYPICAL DETAIL

FOR SECTIONS SEE DRG. No. G57
 FOR STANCHION SCHEDULE & LAYOUT
 SEE DRG. Nos. D40 & D43
 FOR WINDPOST LAYOUT SEE DRG. No. D29

Cast in channels:
 Masonry to be tied to the concrete frame via cast in channels by HALFEN-UNISTRUT (See D124, 21 1331). Channels to be Type 35/15.
 Brick and blockwork to be fixed to cast in channels with HALFEN-UNISTRUT HBF channel ties.
RC walls:
 For RC walls to be clad in masonry, (eg. core walls externally), provide stainless steel cast in channels at 450 vertically and 900 horizontal centres.
RC columns in external walls:
 Allow stainless steel channels in one face and galvanneal mild steel in two faces.
 All channels at 225 vertical centres.
RC columns within internal walls:
 Where an internal wall is built up to an RC column allow mild steel cast in channels at 225 vertical centres in the column faces.

- Notes:
- Do not scale this drawing.
 - Contractor to check all dimensions and report all errors and omissions to the Engineer.
 - Concrete mix to be given which shall conform in all respects with the requirements of our specifications.
 - Design loadings—

KL/PL
KL/PL
KL/PL
 - Ground bearing resistance—

KL/PL

 - Cover to reinforcement shall be—
 - FOR CONCRETE MIXES SEE SPECIFICATION E10 : Clauses 132b, 133a & 133f (for columns)

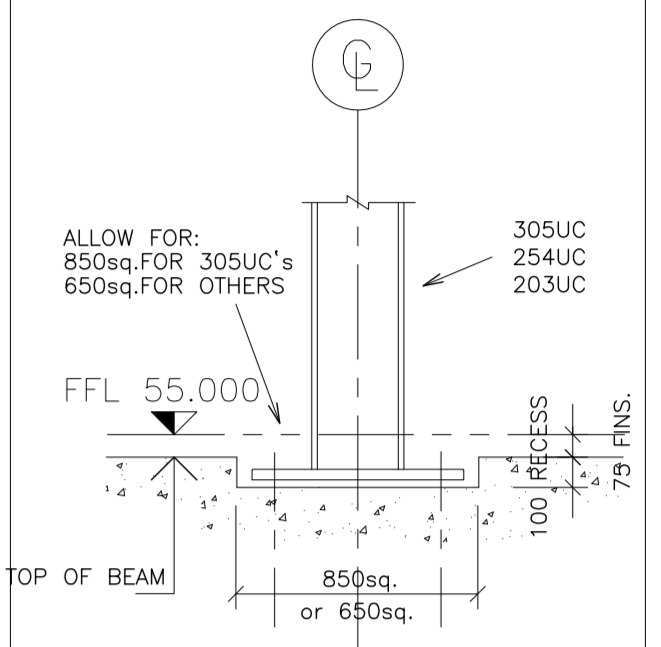

TYPICAL RECESS DETAIL FOR BASEPLATE/HD BOLTS TO ALL STEEL COLUMNS

Reinforcement schedules nos.

Scales
 1:100

Ref.	Detail	By	Date
B	GENERALLY UPDATED	BC	20.10.94
D	CORES 6, 7 & 10 REVISED. SLAB 13 REVISIONS. STAIRS 13, 14, 15, 16, 17, 18, 19, 20, 21, 22, 23, 24, 25, 26, 27, 28, 29, 30, 31, 32, 33, 34, 35, 36, 37, 38, 39, 40, 41, 42, 43, 44, 45, 46, 47, 48, 49, 50, 51, 52, 53, 54, 55, 56, 57, 58, 59, 60, 61, 62, 63, 64, 65, 66, 67, 68, 69, 70, 71, 72, 73, 74, 75, 76, 77, 78, 79, 80, 81, 82, 83, 84, 85, 86, 87, 88, 89, 90, 91, 92, 93, 94, 95, 96, 97, 98, 99, 100, 101, 102, 103, 104, 105, 106, 107, 108, 109, 110, 111, 112, 113, 114, 115, 116, 117, 118, 119, 120, 121, 122, 123, 124, 125, 126, 127, 128, 129, 130, 131, 132, 133, 134, 135, 136, 137, 138, 139, 140, 141, 142, 143, 144, 145, 146, 147, 148, 149, 150, 151, 152, 153, 154, 155, 156, 157, 158, 159, 160, 161, 162, 163, 164, 165, 166, 167, 168, 169, 170, 171, 172, 173, 174, 175, 176, 177, 178, 179, 180, 181, 182, 183, 184, 185, 186, 187, 188, 189, 190, 191, 192, 193, 194, 195, 196, 197, 198, 199, 200, 201, 202, 203, 204, 205, 206, 207, 208, 209, 210, 211, 212, 213, 214, 215, 216, 217, 218, 219, 220, 221, 222, 223, 224, 225, 226, 227, 228, 229, 230, 231, 232, 233, 234, 235, 236, 237, 238, 239, 240, 241, 242, 243, 244, 245, 246, 247, 248, 249, 250, 251, 252, 253, 254, 255, 256, 257, 258, 259, 260, 261, 262, 263, 264, 265, 266, 267, 268, 269, 270, 271, 272, 273, 274, 275, 276, 277, 278, 279, 280, 281, 282, 283, 284, 285, 286, 287, 288, 289, 290, 291, 292, 293, 294, 295, 296, 297, 298, 299, 300, 301, 302, 303, 304, 305, 306, 307, 308, 309, 310, 311, 312, 313, 314, 315, 316, 317, 318, 319, 320, 321, 322, 323, 324, 325, 326, 327, 328, 329, 330, 331, 332, 333, 334, 335, 336, 337, 338, 339, 340, 341, 342, 343, 344, 345, 346, 347, 348, 349, 350, 351, 352, 353, 354, 355, 356, 357, 358, 359, 360, 361, 362, 363, 364, 365, 366, 367, 368, 369, 370, 371, 372, 373, 374, 375, 376, 377, 378, 379, 380, 381, 382, 383, 384, 385, 386, 387, 388, 389, 390, 391, 392, 393, 394, 395, 396, 397, 398, 399, 400, 401, 402, 403, 404, 405, 406, 407, 408, 409, 410, 411, 412, 413, 414, 415, 416, 417, 418, 419, 420, 421, 422, 423, 424, 425, 426, 427, 428, 429, 430, 431, 432, 433, 434, 435, 436, 437, 438, 439, 440, 441, 442, 443, 444, 445, 446, 447, 448, 449, 450, 451, 452, 453, 454, 455, 456, 457, 458, 459, 460, 461, 462, 463, 464, 465, 466, 467, 468, 469, 470, 471, 472, 473, 474, 475, 476, 477, 478, 479, 480, 481, 482, 483, 484, 485, 486, 487, 488, 489, 490, 491, 492, 493, 494, 495, 496, 497, 498, 499, 500, 501, 502, 503, 504, 505, 506, 507, 508, 509, 510, 511, 512, 513, 514, 515, 516, 517, 518, 519, 520, 521, 522, 523, 524, 525, 526, 527, 528, 529, 530, 531, 532, 533, 534, 535, 536, 537, 538, 539, 540, 541, 542, 543, 544, 545, 546, 547, 548, 549, 550, 551, 552, 553, 554, 555, 556, 557, 558, 559, 560, 561, 562, 563, 564, 565, 566, 567, 568, 569, 570, 571, 572, 573, 574, 575, 576, 577, 578, 579, 580, 581, 582, 583, 584, 585, 586, 587, 588, 589, 590, 591, 592, 593, 594, 595, 596, 597, 598, 599, 600, 601, 602, 603, 604, 605, 606, 607, 608, 609, 610, 611, 612, 613, 614, 615, 616, 617, 618, 619, 620, 621, 622, 623, 624, 625, 626, 627, 628, 629, 630, 631, 632, 633, 634, 635, 636, 637, 638, 639, 640, 641, 642, 643, 644, 645, 646, 647, 648, 649, 650, 651, 652, 653, 654, 655, 656, 657, 658, 659, 660, 661, 662, 663, 664, 665, 666, 667, 668, 669, 670, 671, 672, 673, 674, 675, 676, 677, 678, 679, 680, 681, 682, 683, 684, 685, 686, 687, 688, 689, 690, 691, 692, 693, 694, 695, 696, 697, 698, 699, 700, 701, 702, 703, 704, 705, 706, 707, 708, 709, 710, 711, 712, 713, 714, 715, 716, 717, 718, 719, 720, 721, 722, 723, 724, 725, 726, 727, 728, 729, 730, 731, 732, 733, 734, 735, 736, 737, 738, 739, 740, 741, 742, 743, 744, 745, 746, 747, 748, 749, 750, 751, 752, 753, 754, 755, 756, 757, 758, 759, 760, 761, 762, 763, 764, 765, 766, 767, 768, 769, 770, 771, 772, 773, 774, 775, 776, 777, 778, 779, 780, 781, 782, 783, 784, 785, 786, 787, 788, 789, 790, 791, 792, 793, 794, 795, 796, 797, 798, 799, 800, 801, 802, 803, 804, 805, 806, 807, 808, 809, 810, 811, 812, 813, 814, 815, 816, 817, 818, 819, 820, 821, 822, 823, 824, 825, 826, 827, 828, 829, 830, 831, 832, 833, 834, 835, 836, 837, 838, 839, 840, 841, 842, 843, 844, 845, 846, 847, 848, 849, 850, 851, 852, 853, 854, 855, 856, 857, 858, 859, 860, 861, 862, 863, 864, 865, 866, 867, 868, 869, 870, 871, 872, 873, 874, 875, 876, 877, 878, 879, 880, 881, 882, 883, 884, 885, 886, 887, 888, 889, 890, 891, 892, 893, 894, 895, 896, 897, 898, 899, 900, 901, 902, 903, 904, 905, 906, 907, 908, 909, 910, 911, 912, 913, 914, 915, 916, 917, 918, 919, 920, 921, 922, 923, 924, 925, 926, 927, 928, 929, 930, 931, 932, 933, 934, 935, 936, 937, 938, 939, 940, 941, 942, 943, 944, 945, 946, 947, 948, 949, 950, 951, 952, 953, 954, 955, 956, 957, 958, 959, 960, 961, 962, 963, 964, 965, 966, 967, 968, 969, 970, 971, 972, 973, 974, 975, 976, 977, 978, 979, 980, 981, 982, 983, 984, 985, 986, 987, 988, 989, 990, 991, 992, 993, 994, 995, 996, 997, 998, 999, 1000		

Client:
 BURFORD GROUP PLC
 Project:
 LONDON:
 FINCHLEY ROAD
 DEVELOPMENT

Description:
 LEVEL 1
 FIRST FLOOR C.A.
 ZONE C

WORKING DRAWING

CONSULTING ENGINEERS
 BIRMINGHAM 0121 414 1989
 BRISTOL 0117 929 2244
 CARDIFF 01222 810785
 EXETER 7651
 LONDON
 MANCHESTER
 WAKEFIELD

CLARKE BOND PARTNERSHIP

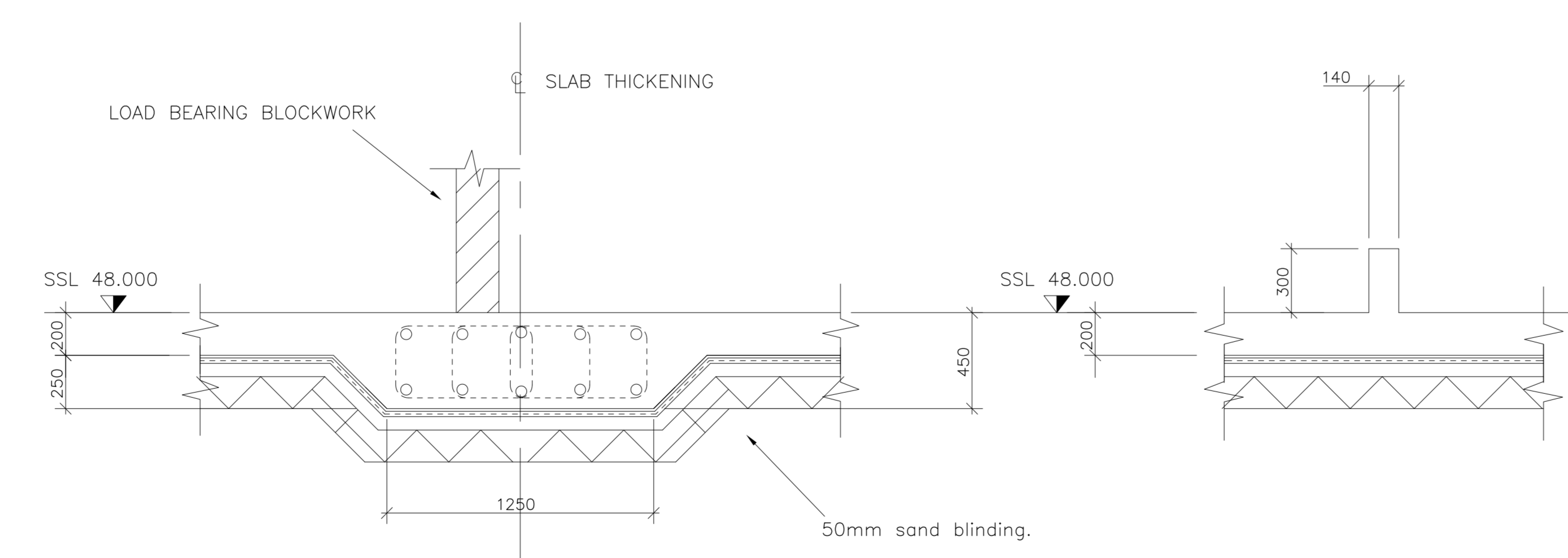
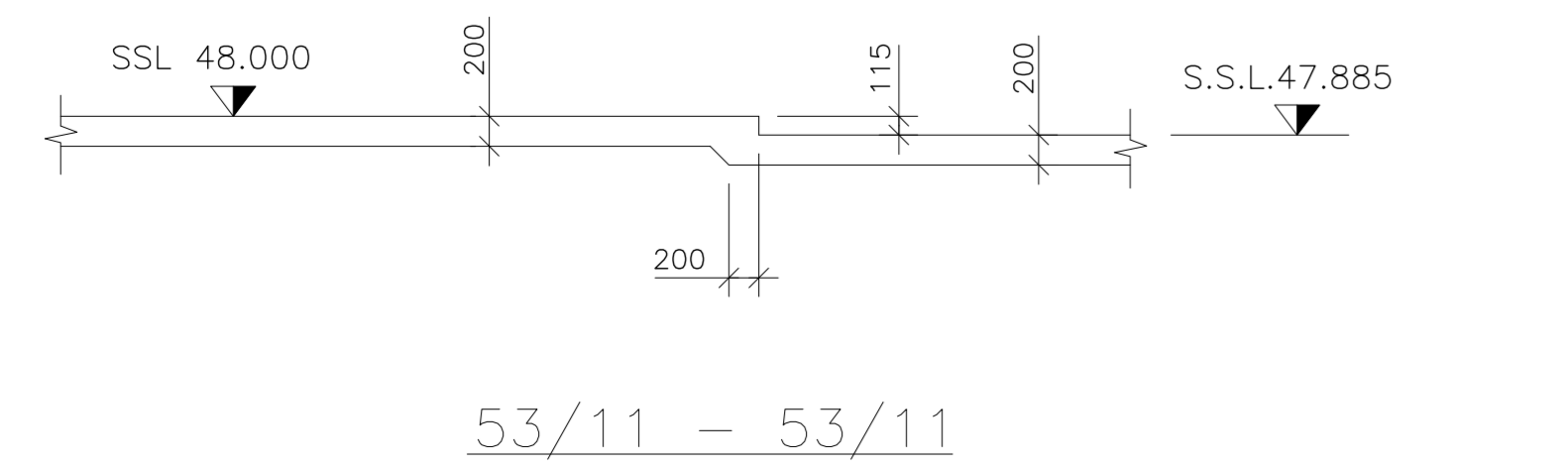
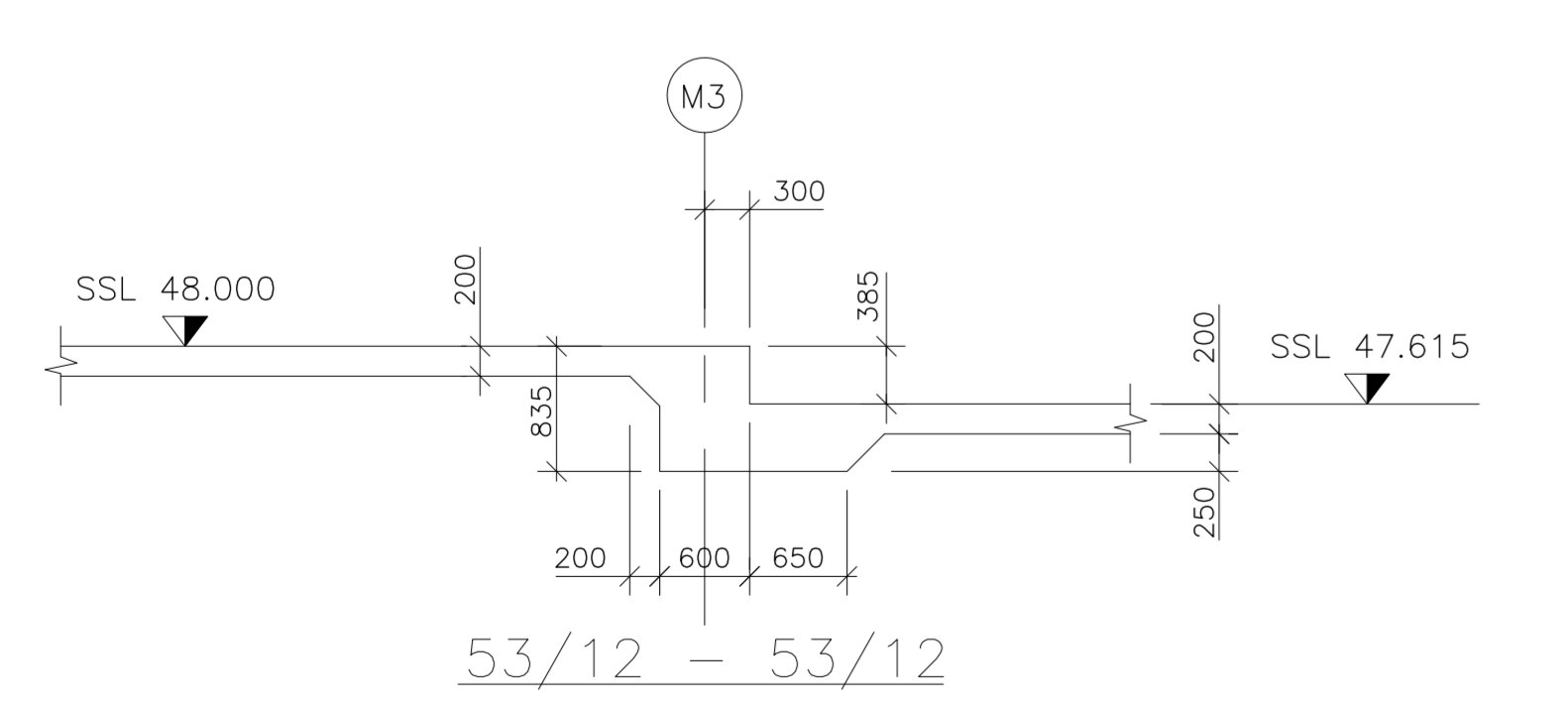
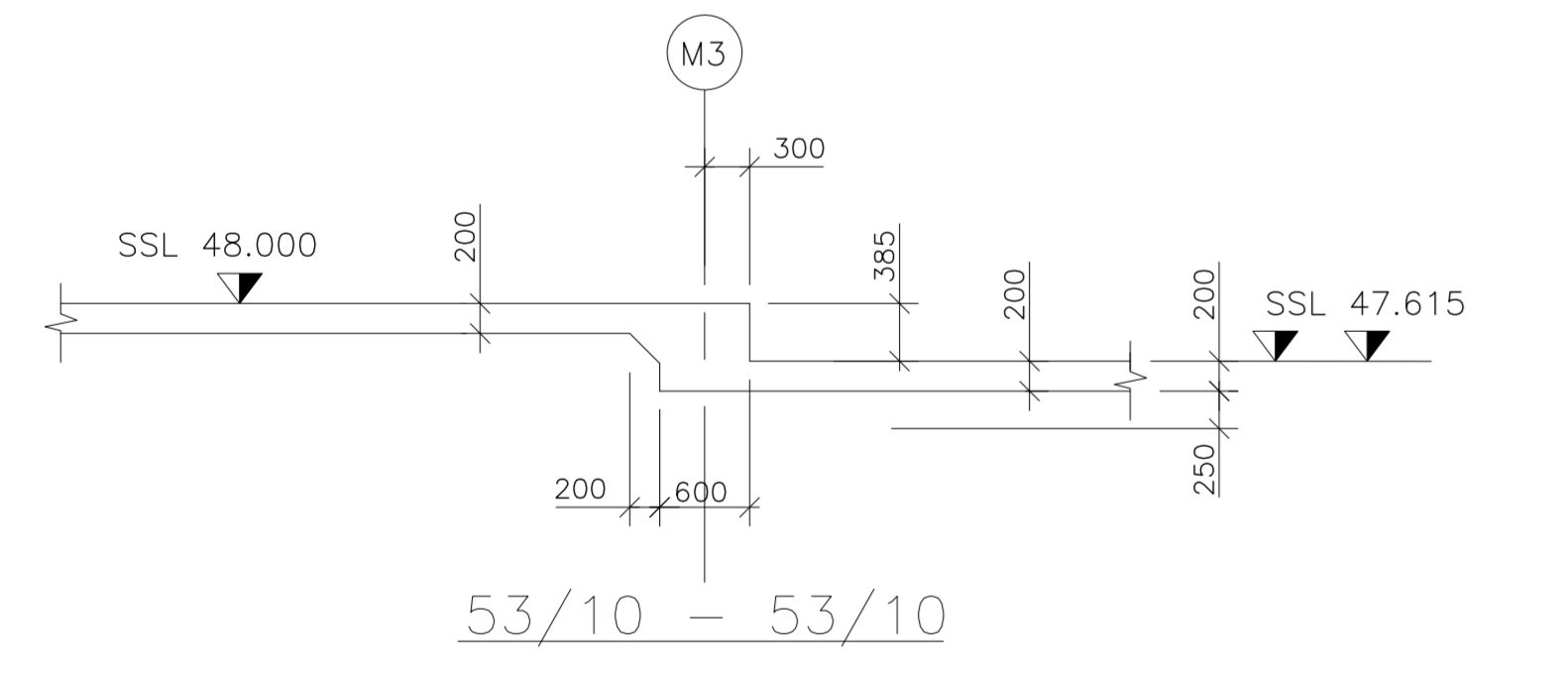
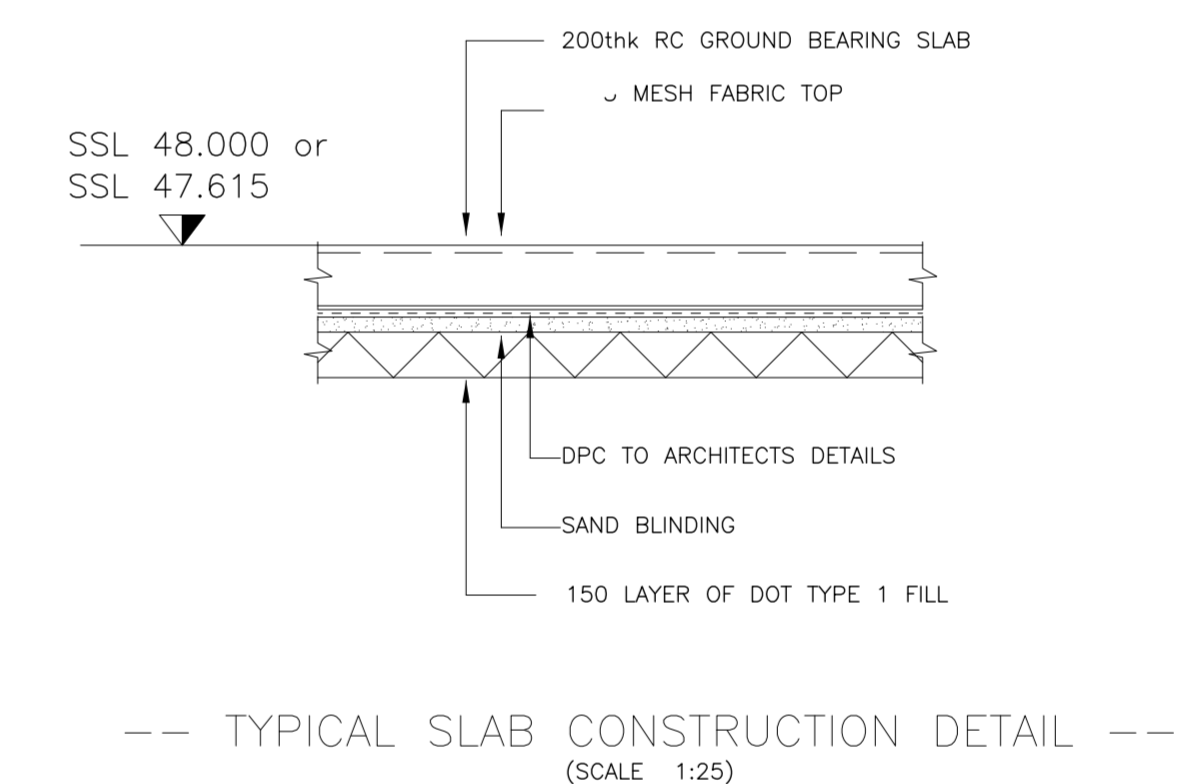
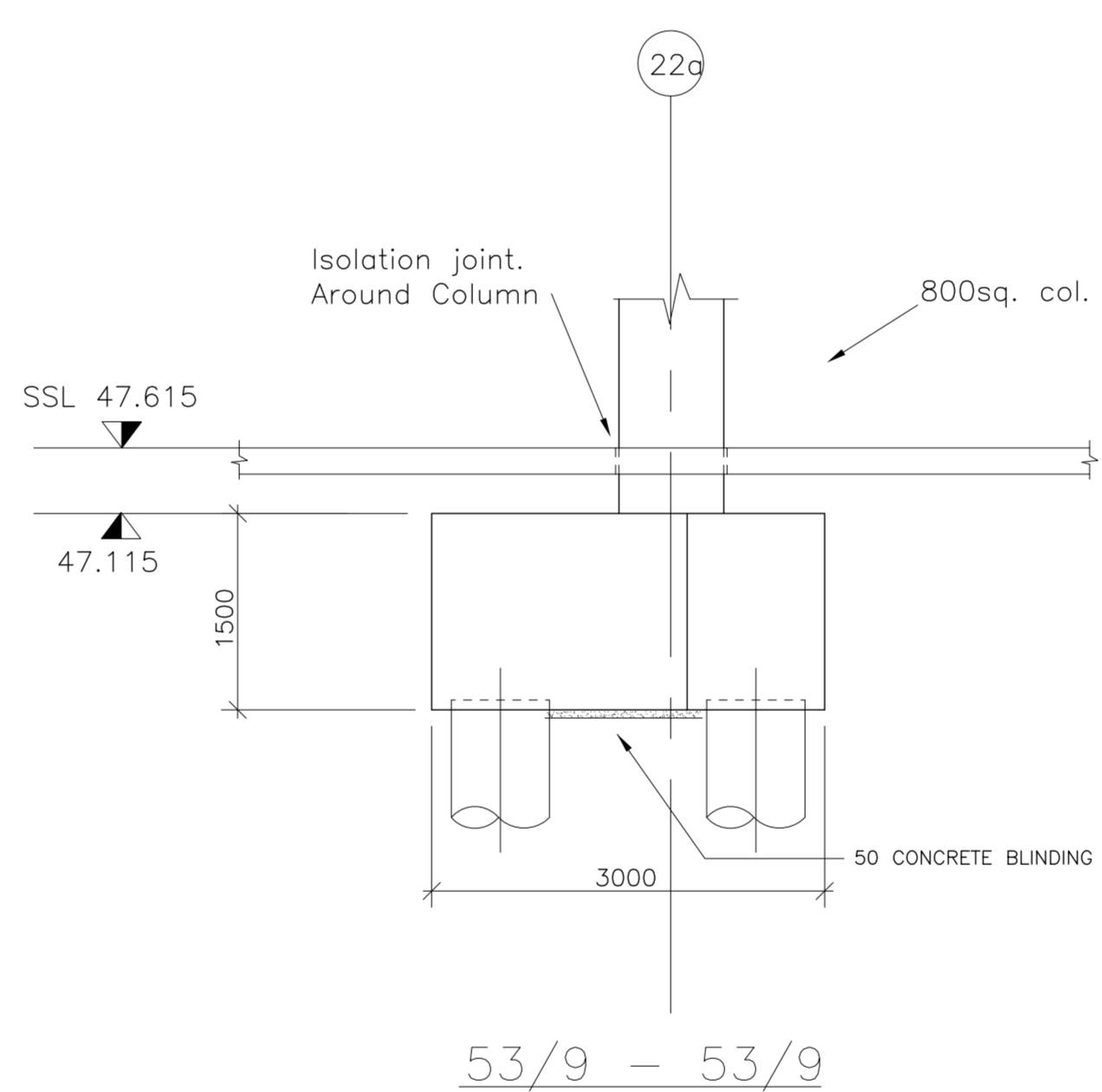
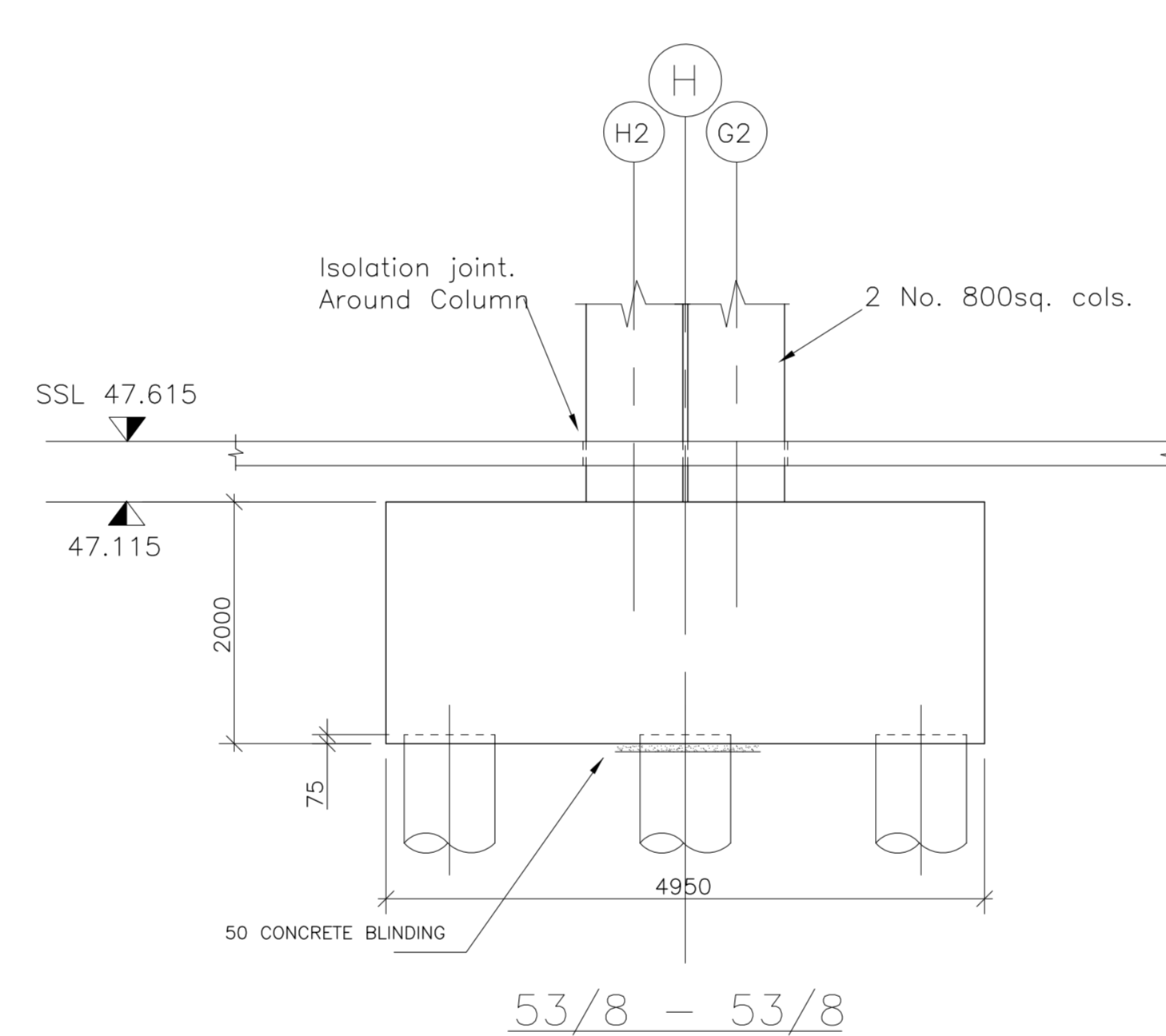
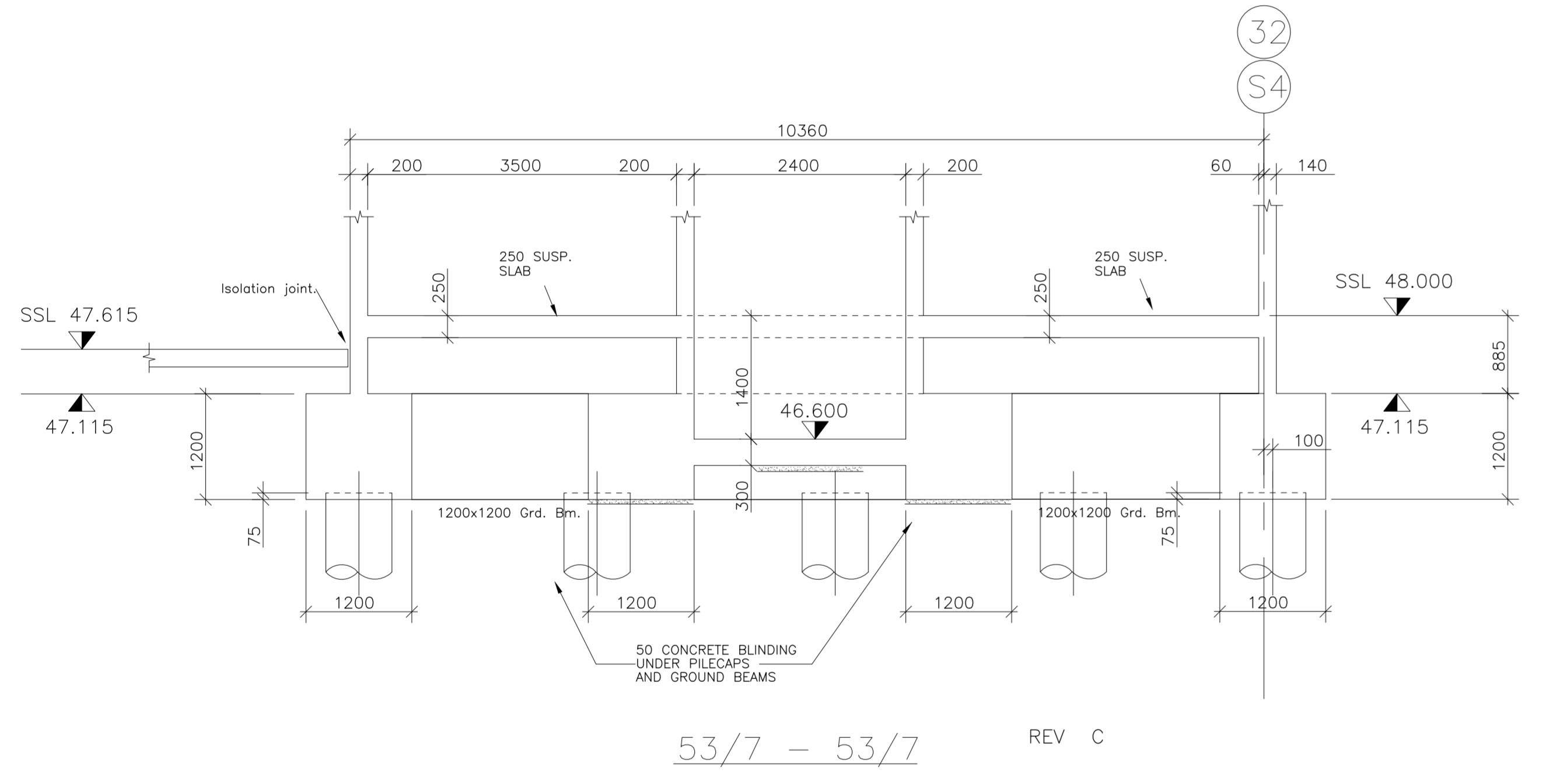
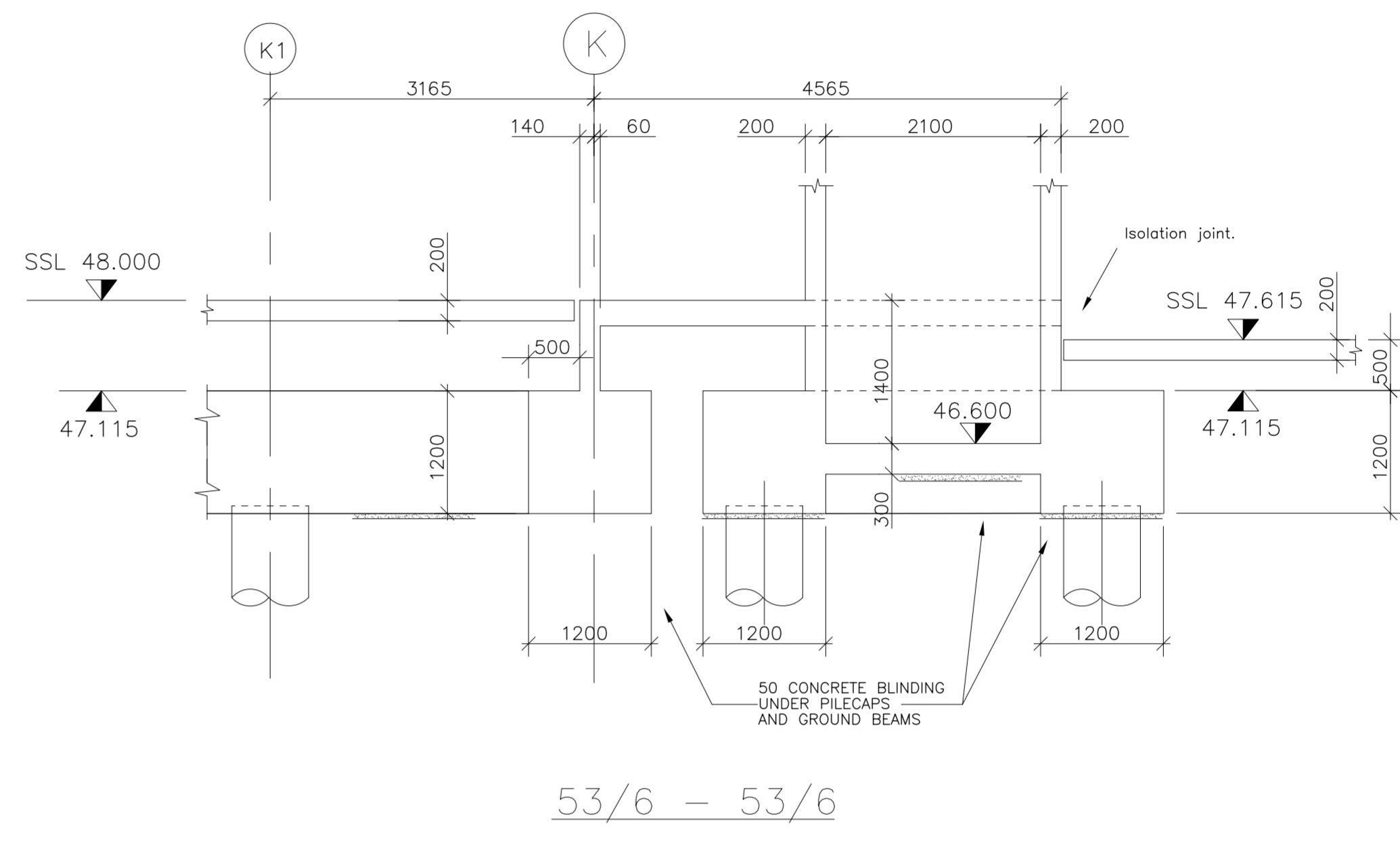
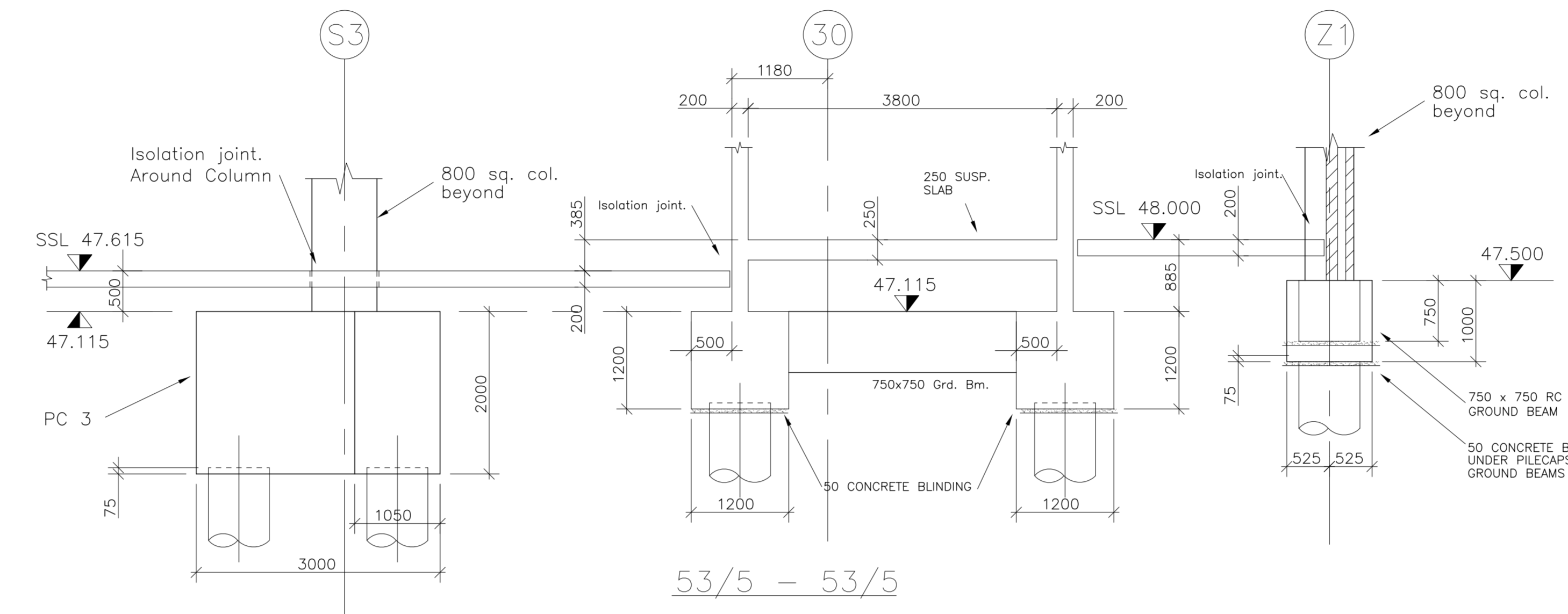
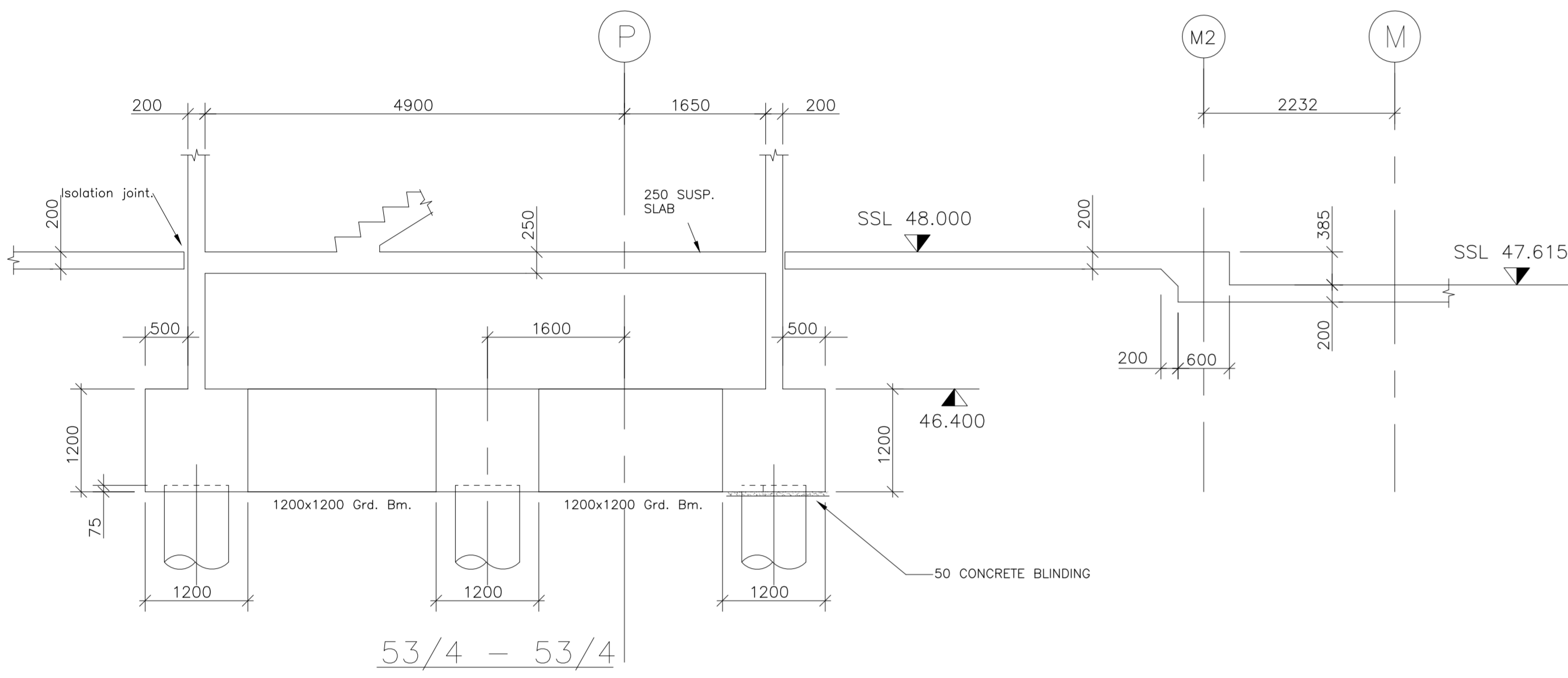
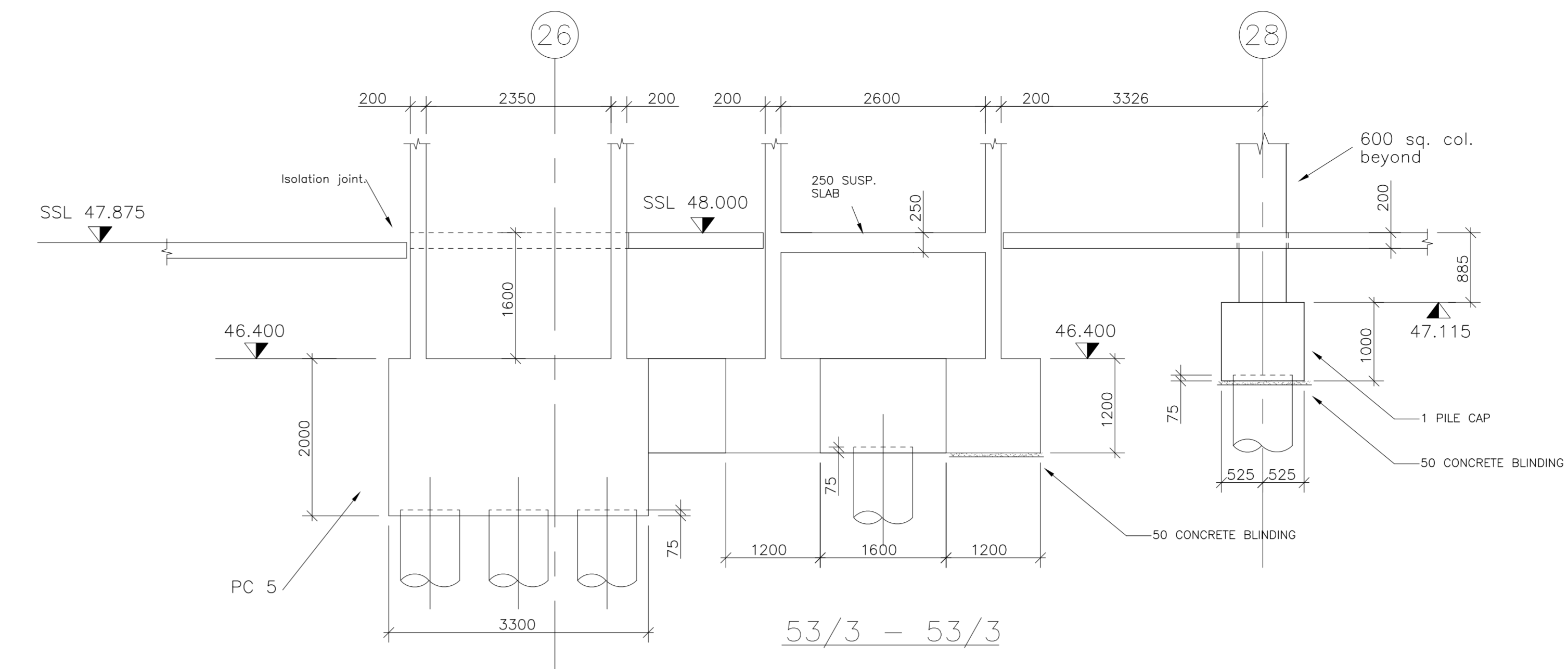
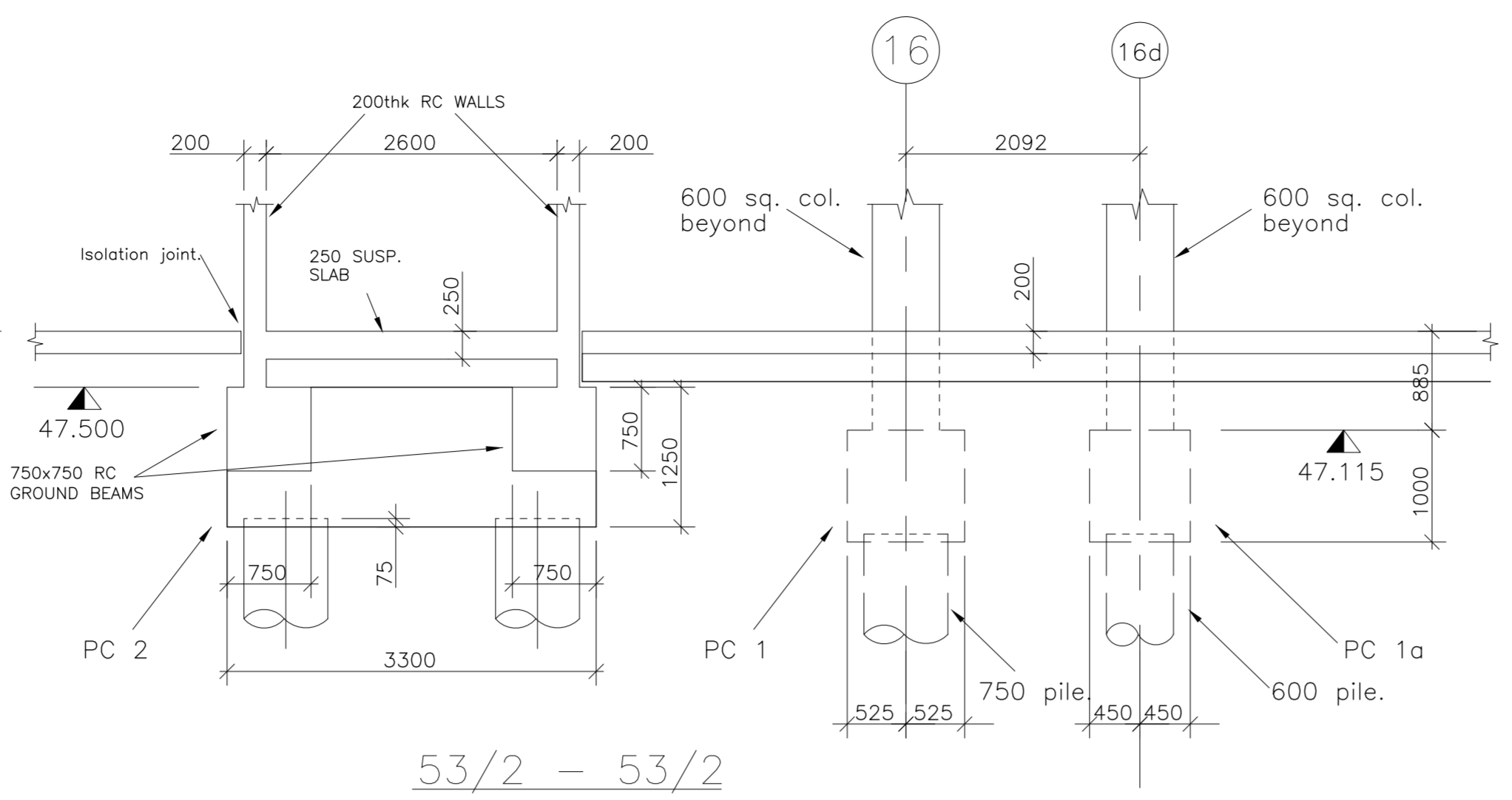
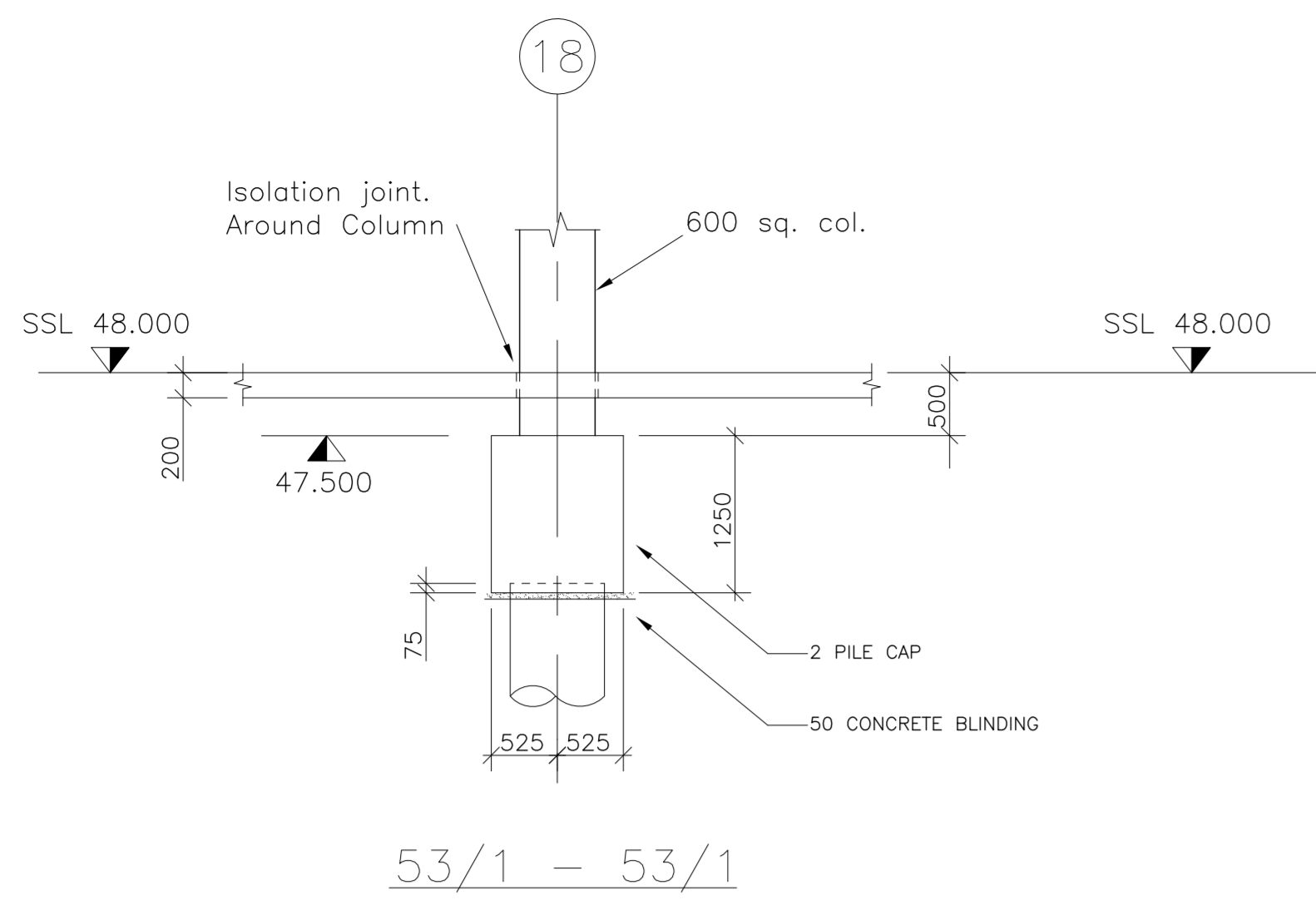

54/9 - 54/9
TYPICAL BUND WALL DETAIL
(SCALE 1:20)

53/13 - 53/13
TYPICAL DRAINAGE CHANNEL DETAIL
(SCALE 1:25)

53/14 - 53/14
TYPICAL DRAINAGE CHANNEL DETAIL
(SCALE 1:25)

53/15 - 53/15
TYPICAL SLAB STRENGTHENING DETAIL FOR SAINSBURYS MEZZANINE WALLS/COLUMNS
FOR LOCATION AND SETTING OUT OF REQUIRED BEAM STRIPS REFER TO ARCHITECTS DETAILS.

- Notes:
- 1 Do not scale this drawing.
 - 2 Contractor to check all dimensions and report all errors and omissions to the Engineer.
 - 3 Concrete mix to be given which shall conform to all aspects with the requirements of our specifications.
 - 4 Design loadings -
 - 5 Ground bearing resistance -
 - 6 Cover to reinforcement shall be -

Reinforcement schedule nos.

Scale: 1:50

Ref.	Detail	By	Date
A	REVISIONS MARKED THIS		18.12.96
B	REVISIONS MARKED THIS		18.3.97
C	ALL SECTIONS UPDATED TO SUIT CHANGES TO LAYOUTS, SECTIONS 53/14, 53/15, 53/16. ADDER	BC	25.97
D	DEPTH OF LIFT PUT ON SECTIONS 53/14 & 53/17 REVISED PLUS MINOR AMENDMENTS	BC	16.5.97

Client: BURFORD GROUP PLC

Project: LONDON: FINCHLEY ROAD DEVELOPMENT.

Description: LEVEL 0 GENERAL ARRANGEMENT SECTIONS ZONE B.

WORKING DRAWING

CONSULTING ENGINEERS

BIRMINGHAM 0121 414 1989
BRISTOL 0117 929 2244
CARDIFF 01222 810785
EXETER 01392 831861
LONDON 0171 255 1998
MANCHESTER 0161 962 2974
WAKEFIELD 01924 823772

CLARKE BOND PARTNERSHIP

Project No. 145000 | Level Zone Drawing No. B G.53
Revision: A | B | C | D
Drawn By: Checked: Date: NOV 96

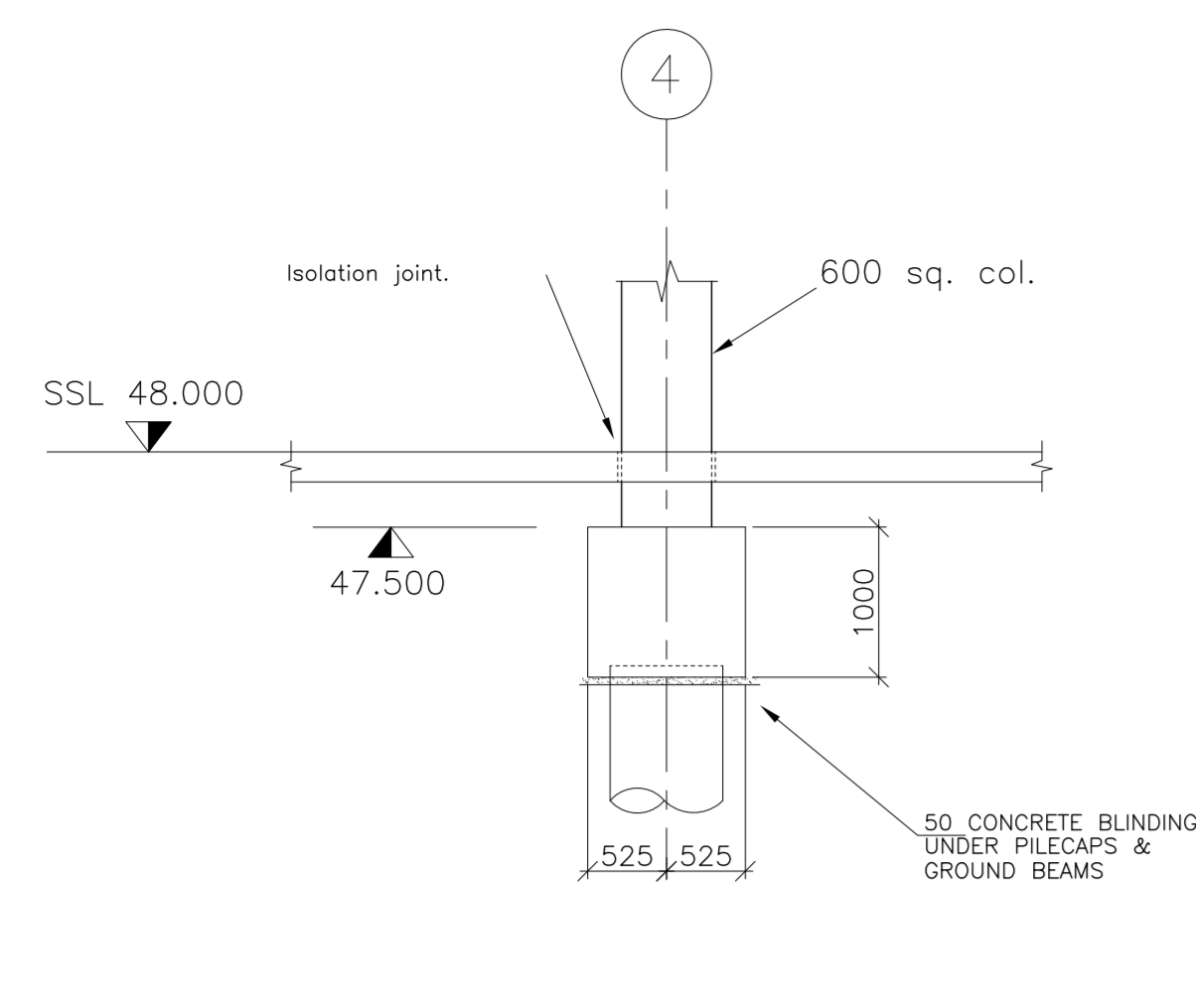

54/1 - 54/1

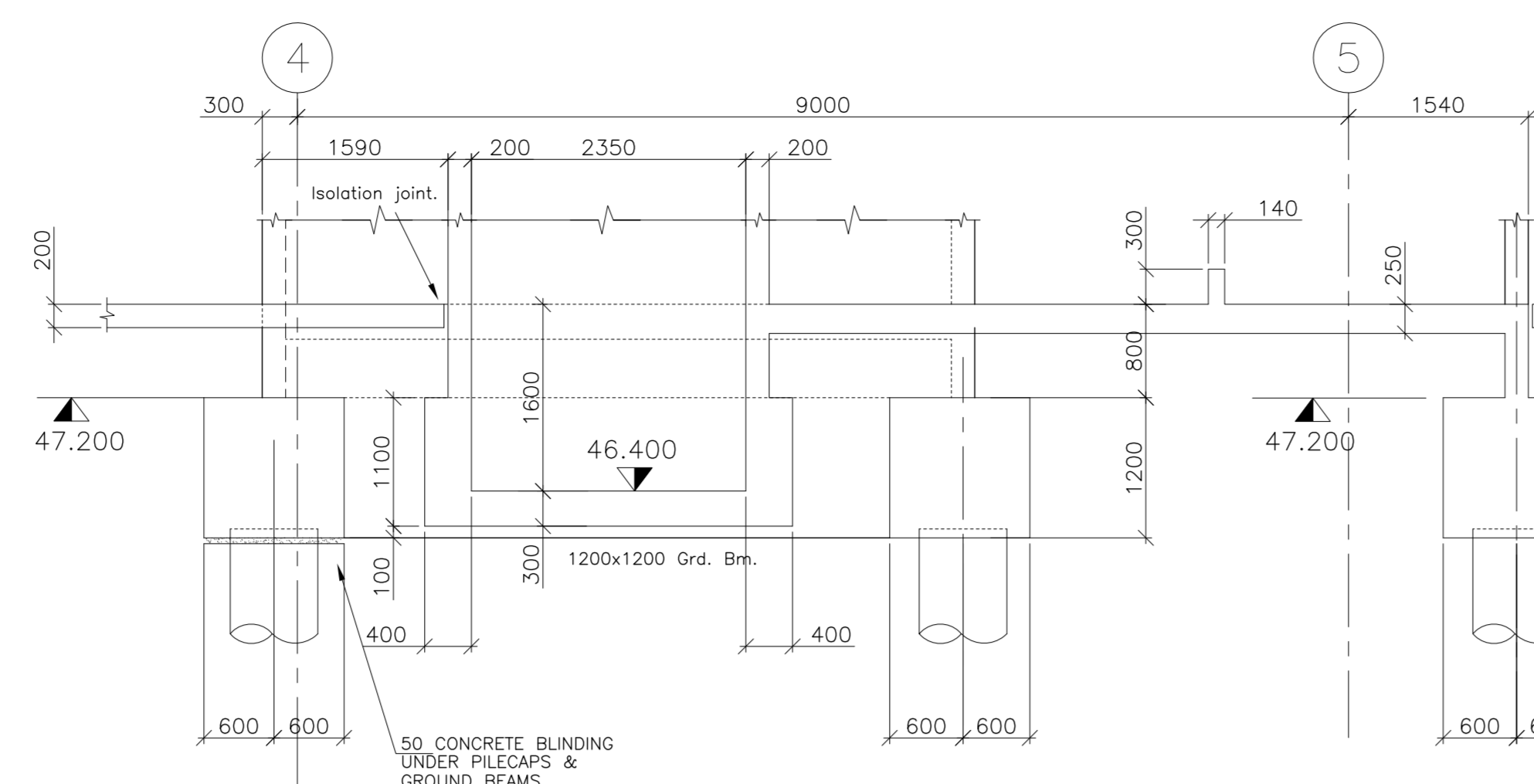

54/2 - 54/2

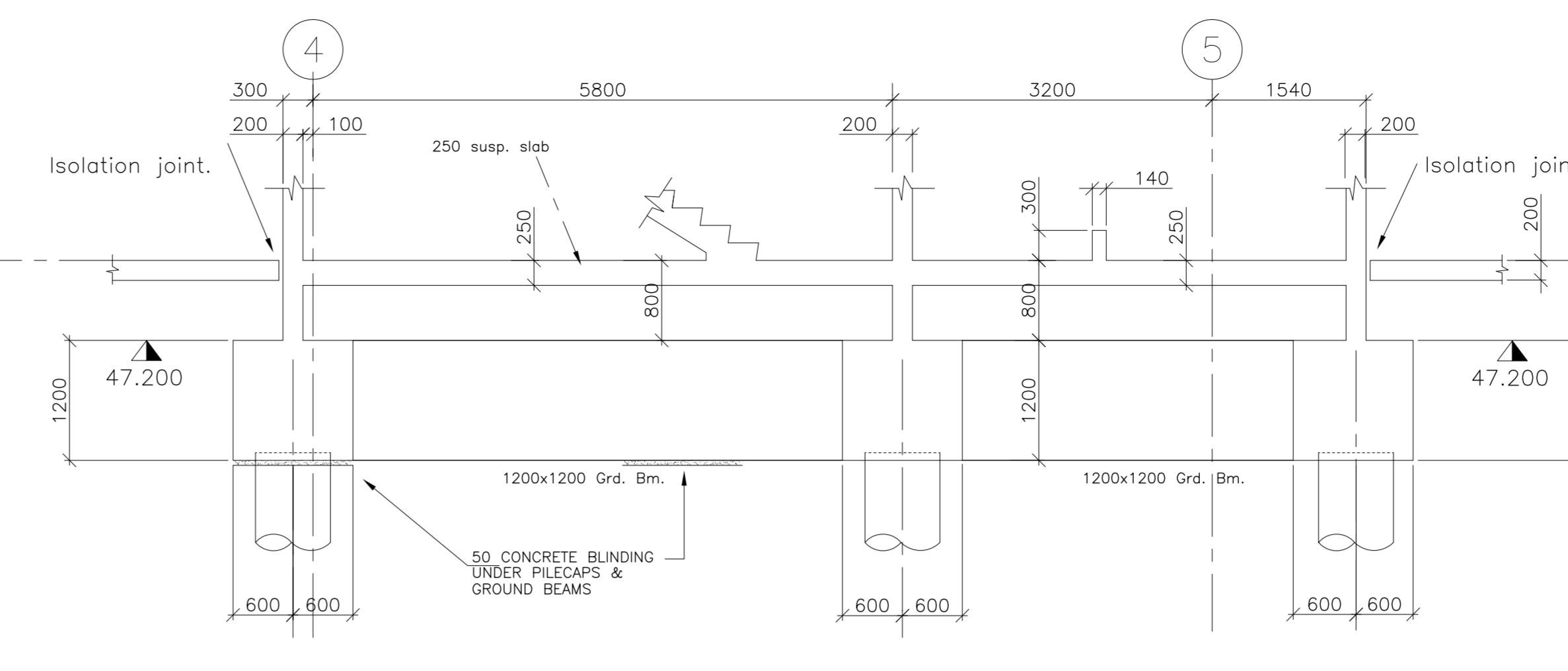

54/3 - 54/3

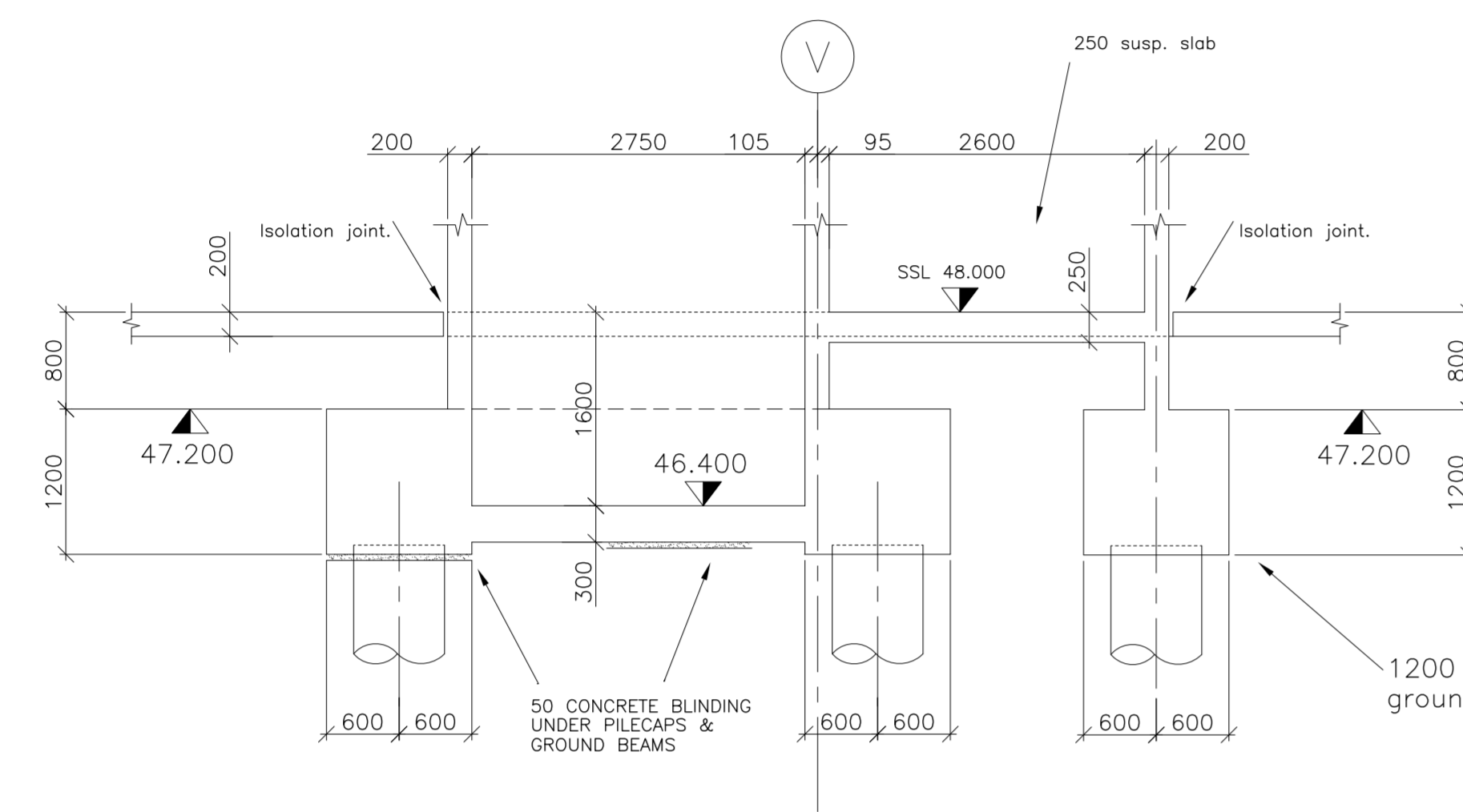

54/4 - 54/4

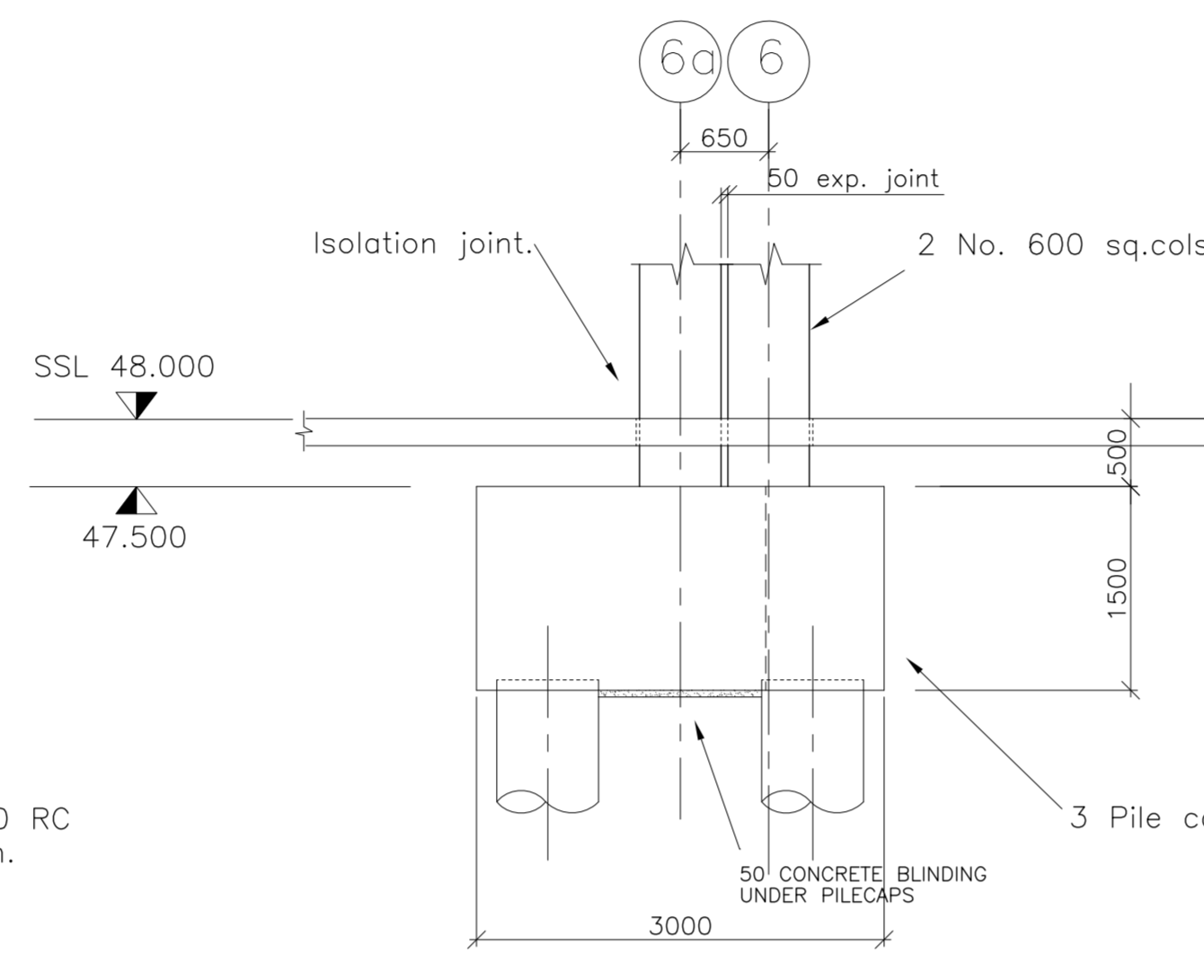

54/7 - 54/7

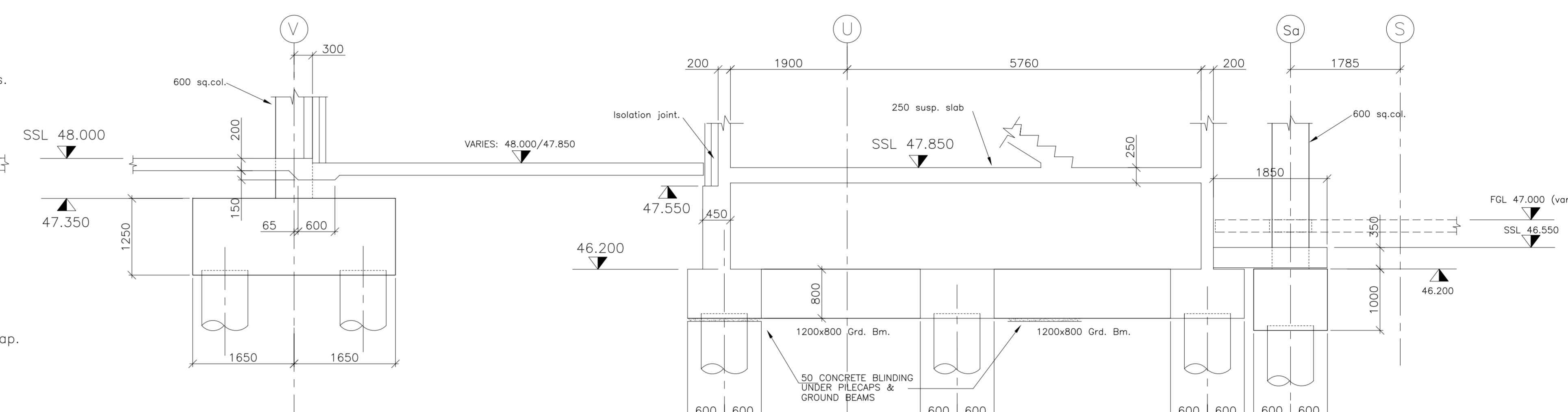

54/6 - 54/6

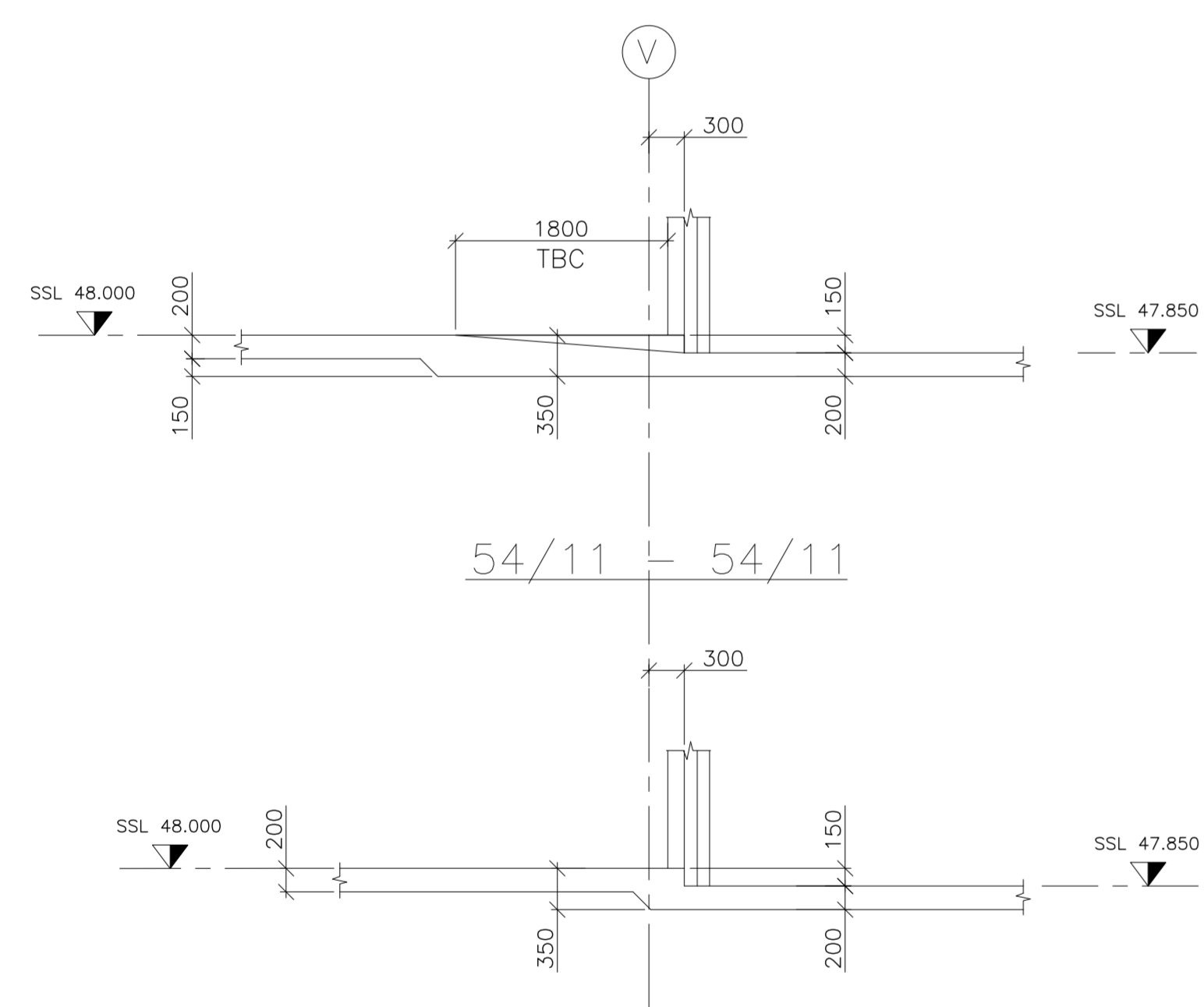

54/11 - 54/11

54/10 - 54/10

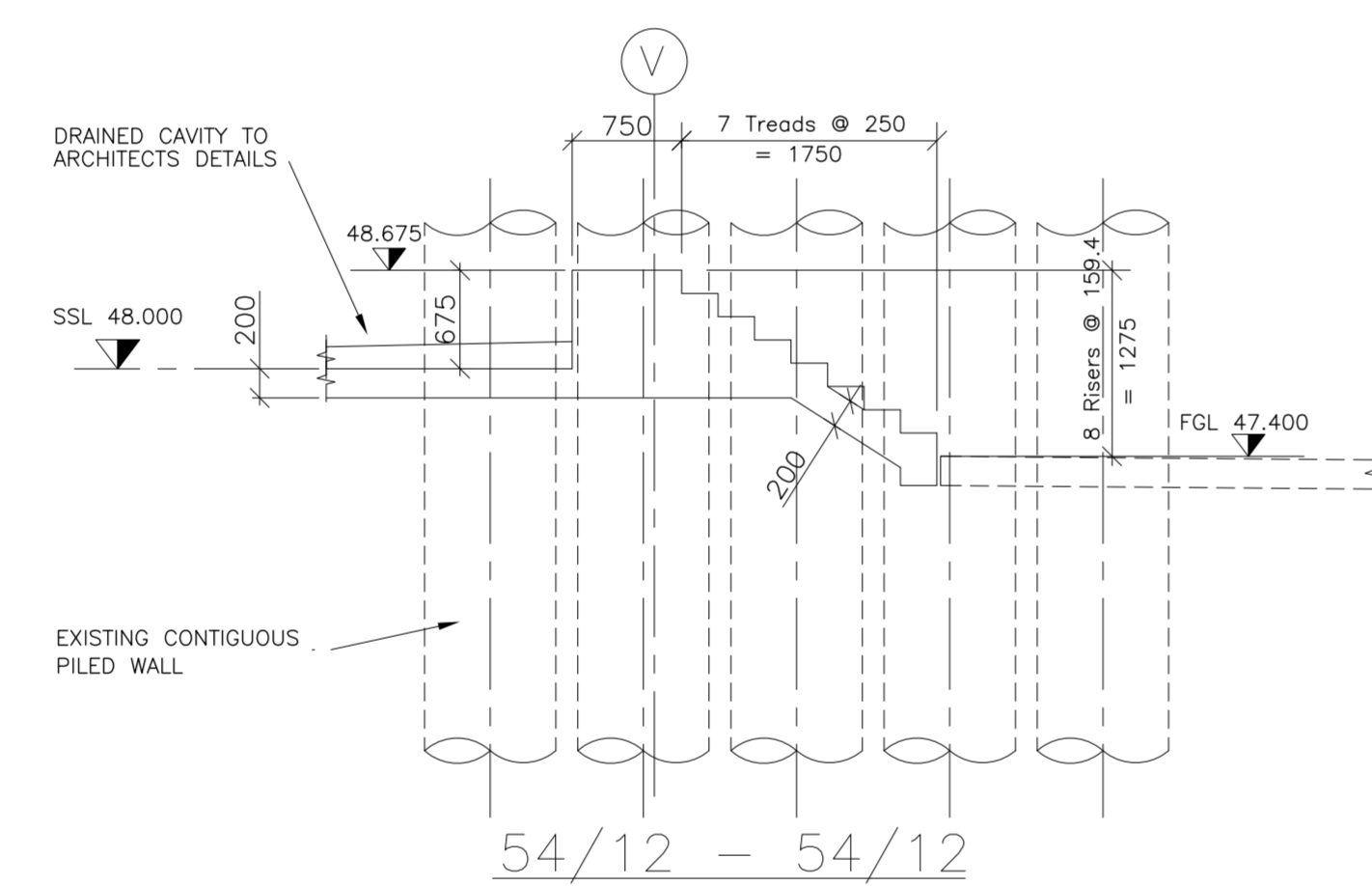

54/12 - 54/12

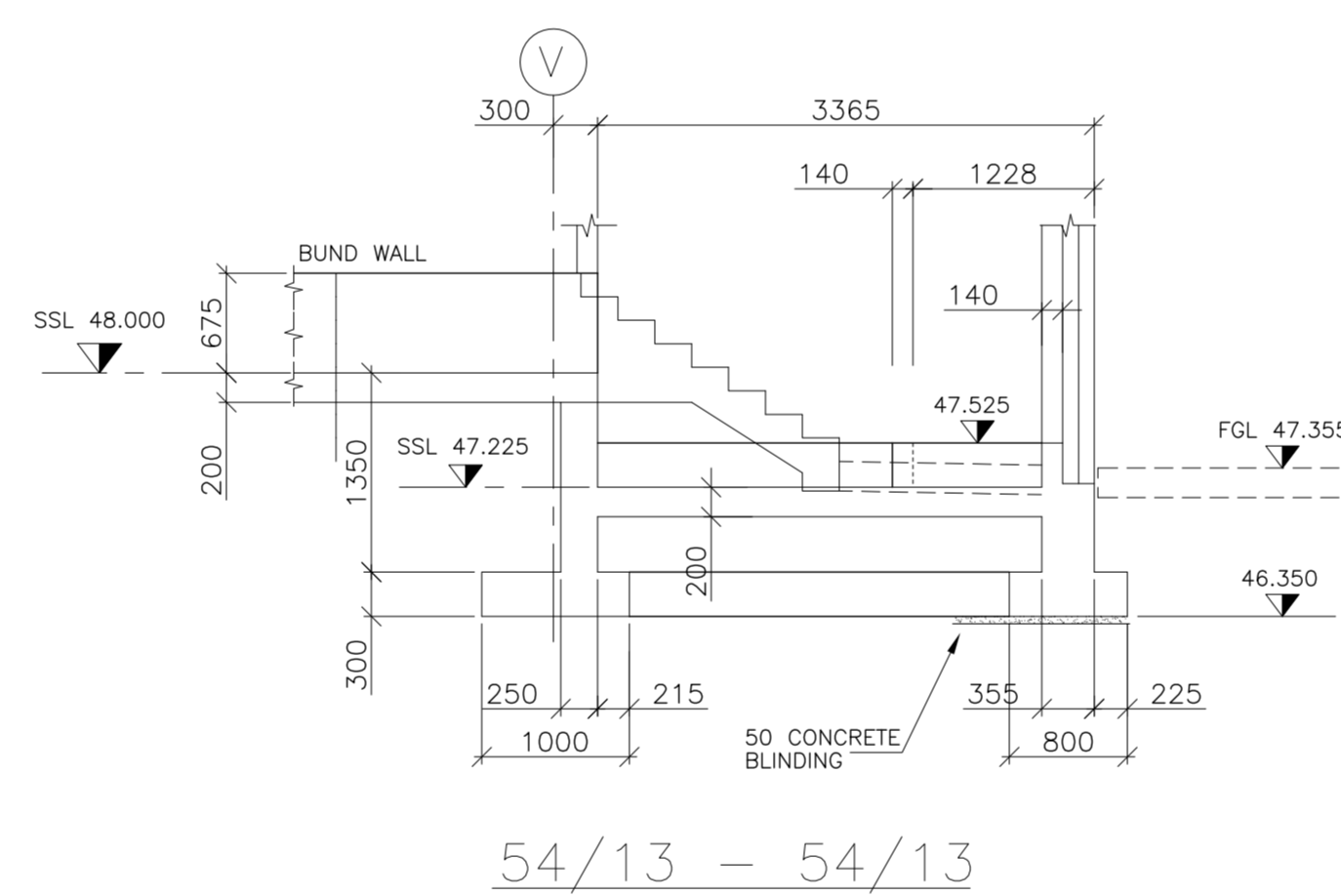

54/13 - 54/13

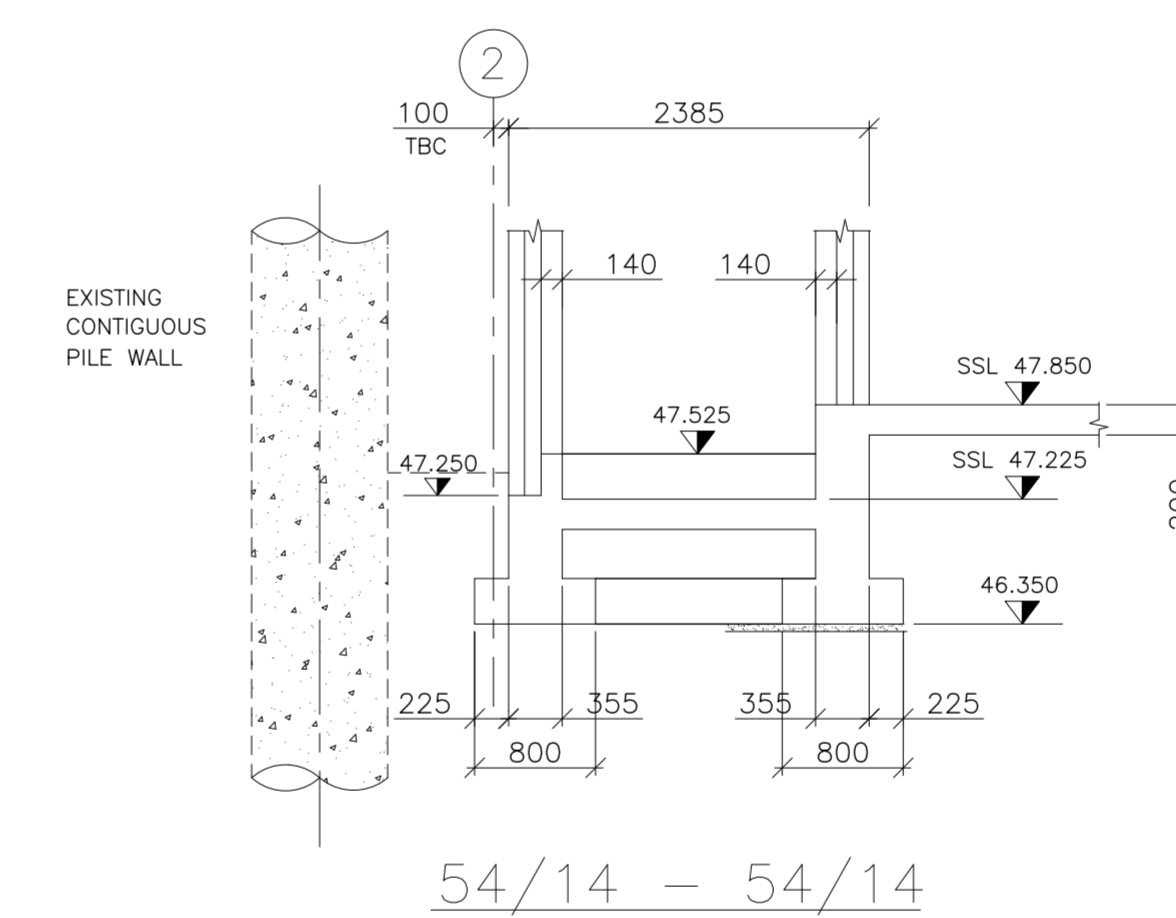

54/14 - 54/14

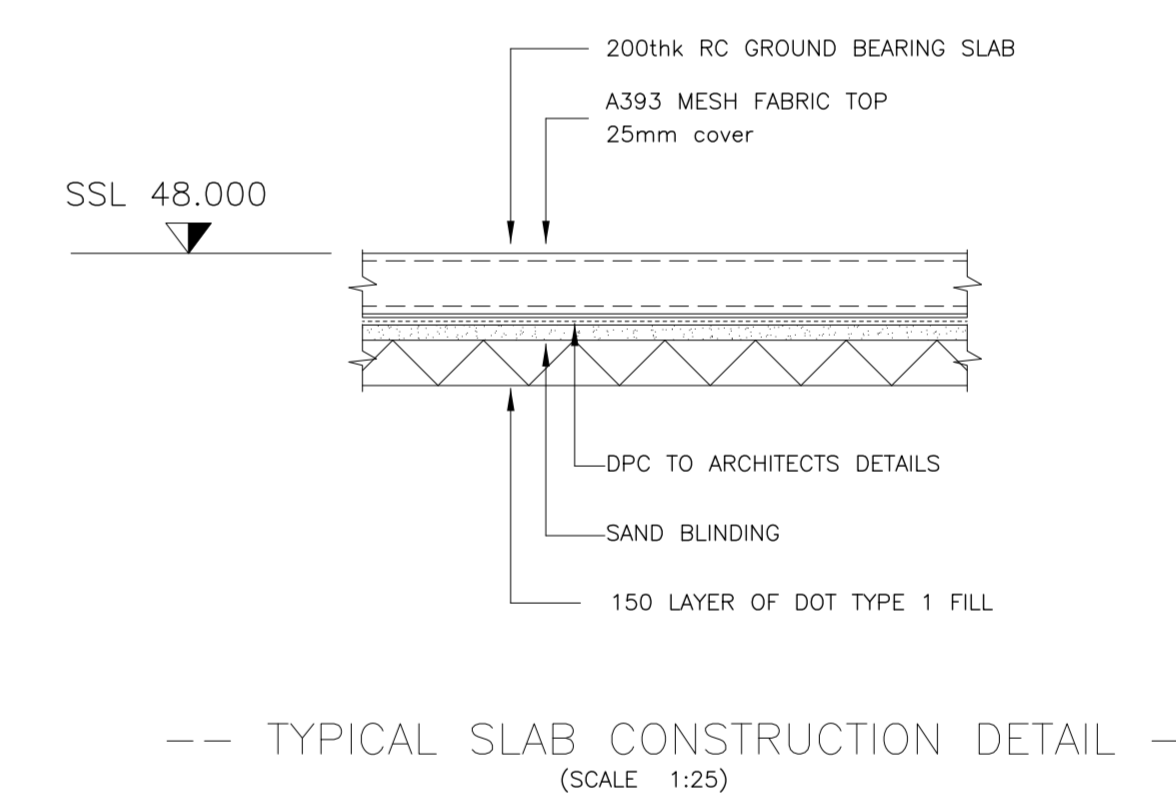

--- TYPICAL SLAB CONSTRUCTION DETAIL ---
(SCALE 1:25)

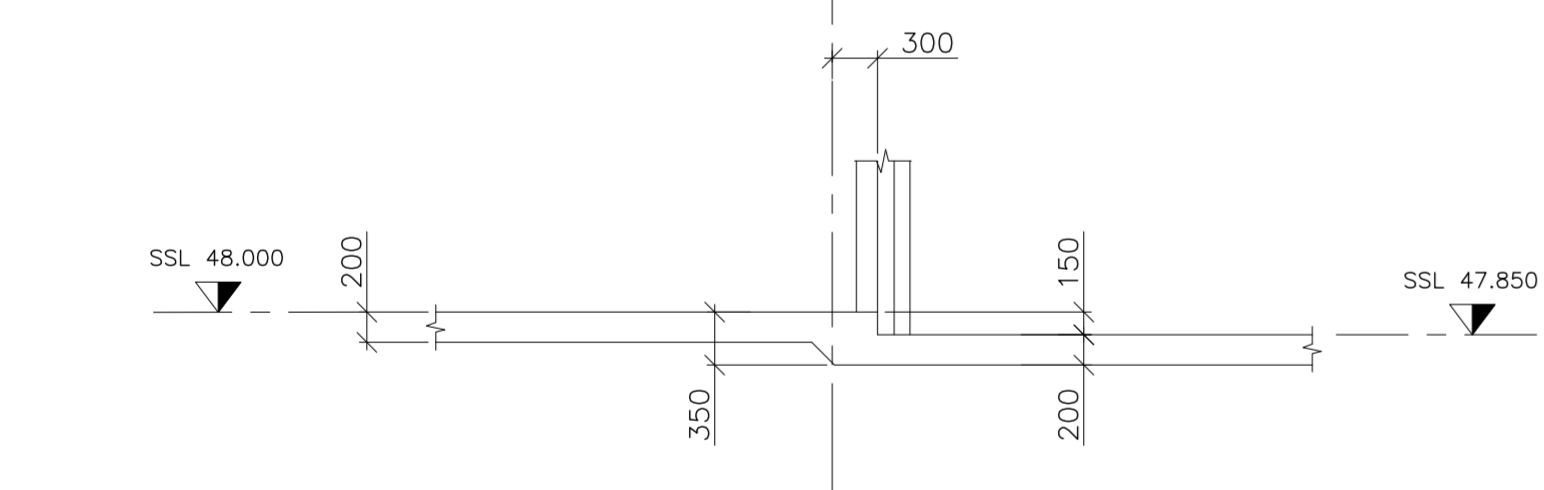

54/15 - 54/15

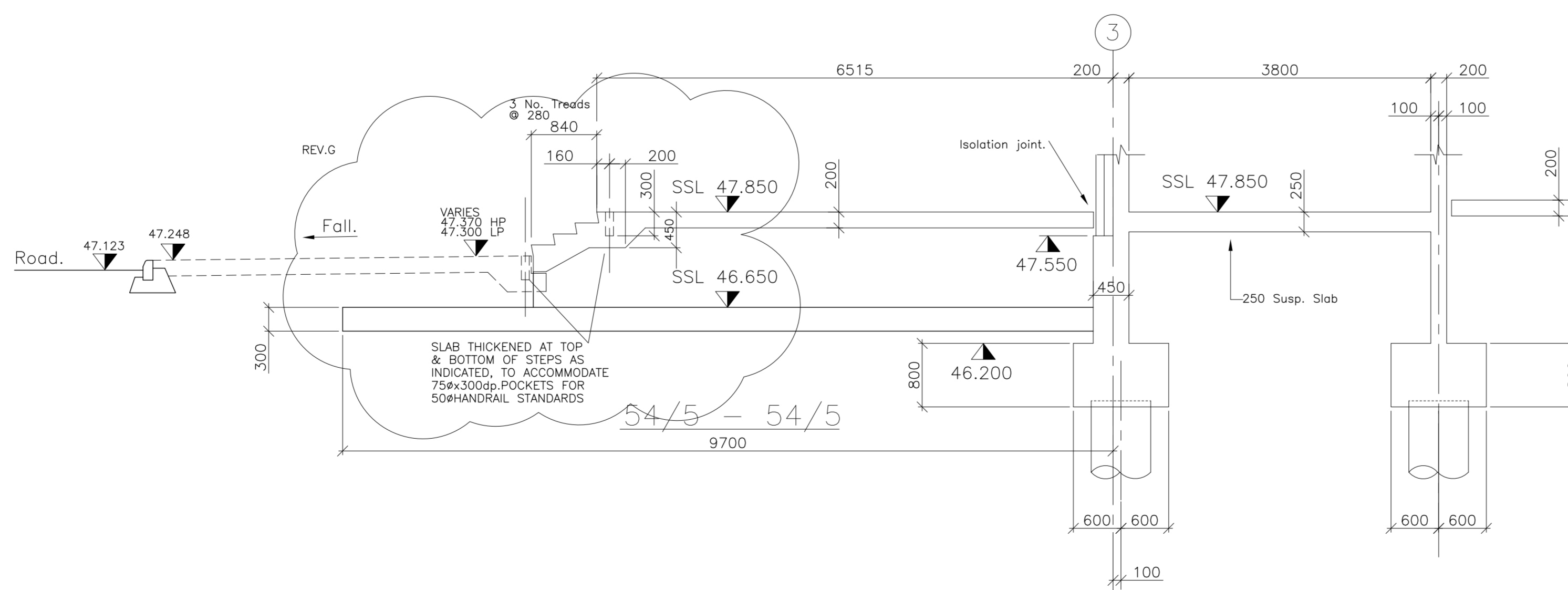

54/5 - 54/5

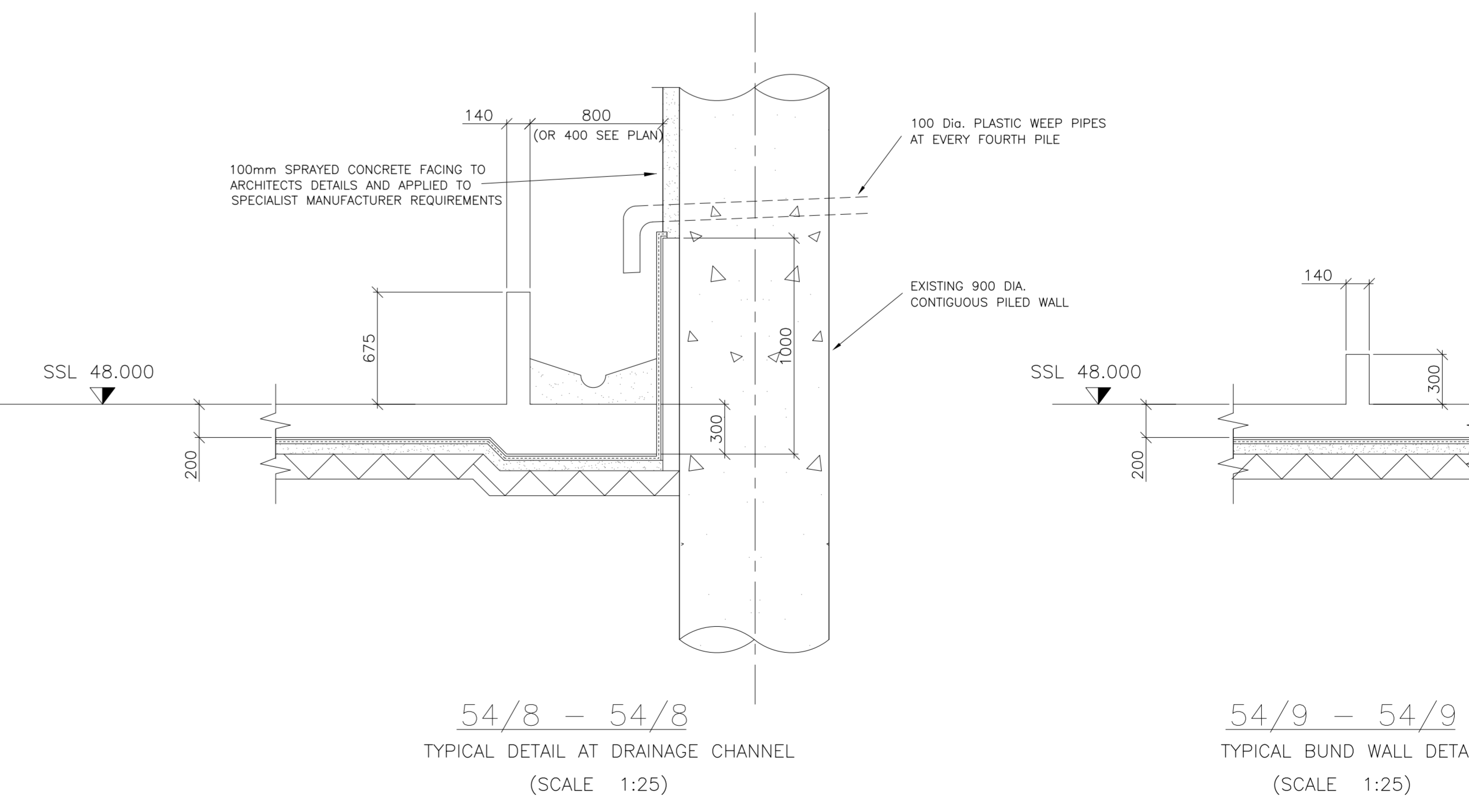

54/8 - 54/8
TYPICAL DETAIL AT DRAINAGE CHANNEL
(SCALE 1:25)

54/9 - 54/9
TYPICAL BUND WALL DETAIL
(SCALE 1:25)

FOR LOCATION OF SECTIONS
SEE DRG. Nos. G07 & G11

- Notes:
- 1 Do not scale this drawing.
 - 2 Contractor to check all dimensions and report all errors and omissions to the Engineer.
 - 3 Concrete mix to be given which shall conform to all aspects with the requirements of the specifications. SEE NOTE 7 BELOW
 - 4 Design loadings -
 - 5 Ground bearing resistance -
 - 6 Cover to reinforcement shall be -
 - 7 FOR CONCRETE MIXES SEE SPECIFICATION E10 - Clauses 132b, 133b & 135 (for columns)

4 Design loadings -	KL/MP
	KL/MP
	KL/MP
5 Ground bearing resistance -	KL/MP

Reinforcement schedule nos.

Scale	1:50
-------	------

Ref.	Detail	By	Date
A	REVISIONS MARKED THIS	BC	20.12.98
B	SECTIONS 54/8 & 54/9 ADDED REVISIONS MARKED THIS	BC	7.4.97
C	ALL SECTIONS UPDATED TO SUIT CHANGES TO PLAN SECTIONS 54/10 & 54/11 ADDED	BC	25.4.97
D	SECTIONS 54/12, 54/13, 54/14 & 54/15 ADDED	BC	30.4.97
E	SECTIONS 54/11, 54/12, 54/13, 54/14, 54/15 AMENDED	BC	14.5.97
F	SECTIONS 54/8, 54/9 AMENDED MARKED THIS	GG	30.7.97
G	THICKENING ADDED TO ESCAPE STAIRS TO ACCOMMODATE HANDRAIL STANDARDS	RJD	20.10.97

Client: BURFORD GROUP PLC

Project: LONDON: FINCHLEY ROAD DEVELOPMENT.

Description: FOUNDATION/LEVEL 0 GENERAL ARRANGEMENT SECTIONS

ZONE C

WORKING DRAWING

CONSULTING ENGINEERS

BIRMINGHAM 0121 414 1989
BRISTOL 0117 929 2244
CARDIFF 01222 810785
EXETER 01392 831861
LONDON 0171 255 1998
MANCHESTER 0161 962 2974
WAKEFIELD 01924 823773

CLARKE BOND PARTNERSHIP

Project No. 14500 | Zone C | Drawing No. G.54

Revision: A | B | C | D | E | F | G |

Drawn by: Checked by: Date: NOV'96

Project No. 14500 | Level Zone Drawing No. A G.50

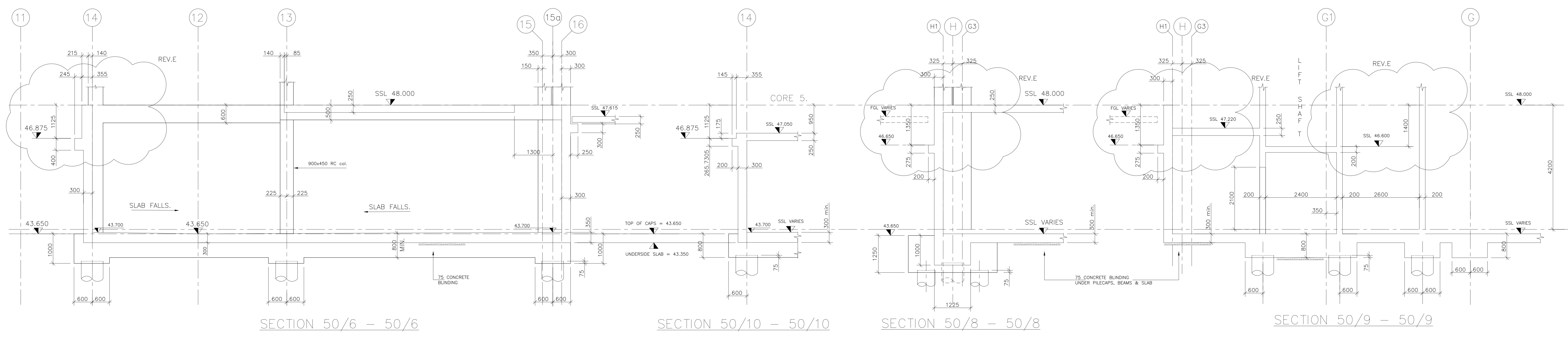
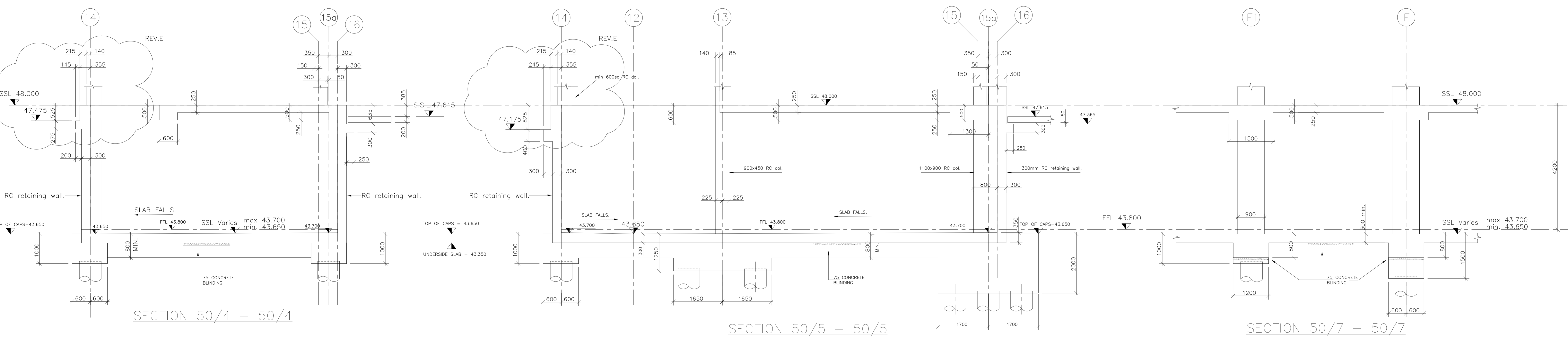
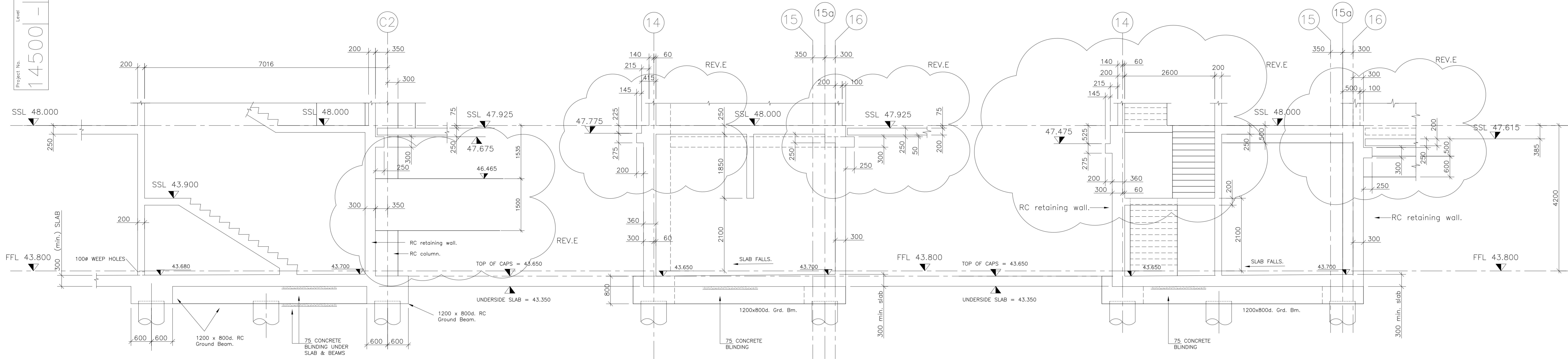

- Notes:
1. Do not scale this drawing.
 2. Contractor to check all dimensions and report all errors and omissions to the Engineer.
 3. Concrete mix to be grade which shall conform to all aspects with the requirements of our specifications. SEE NOTE 7 BELOW.
 4. Design loadings -
 5. Ground bearing resistance -
 6. Cover to reinforcement shall be -
 7. FOR CONCRETE MIXES SEE SPECIFICATION E10 : Clauses 132b, 133a & 133c (for columns)

Reinforcement schedule nos.

Scale: 1:50

Ref.	Detail.	By	Date.
A	Dimensions added	-	15.12.04
B	NB DETAILS ADDED, SECTION 10-10 ADDED.	-	20.12.04
C	SECTIONS B-E 0-9 WALL REINFORCED, SLAB FALLS ADDED, RETAINING WALL THICKNESS REVISED, SLAB FALLS	GG	14.3.07
D	ALL SECTIONS REVISED TO SUIT	BC	28.4.07
E	ALL REVISIONS CLOTTED	AG	3.7.07

Client: BURFORD GROUP PLC

Project: LONDON: FINCHLEY ROAD DEVELOPMENT.

Description: BASEMENT G.A. SECTIONS. ZONE A.

WORKING DRAWING

CONSULTING ENGINEERS

BRISTOL 0117 929 2244
 CARDIFF 01222 810785
 EXETER 01426 831861
 LONDON 0171 255 1998
 MANCHESTER 0161 962 2974
 WAKEFIELD 01924 823772

CLARKE BOND PARTNERSHIP

Project No. 14500 | Level Zone Drawing No. A G.50

Revision: A | B | C | D | E

Drawn by: [] Checked by: [] Date: DEC'06

FOR LOCATION OF SECTIONS INDICATED REFER TO DRG. No. 14500/0/A/G04.

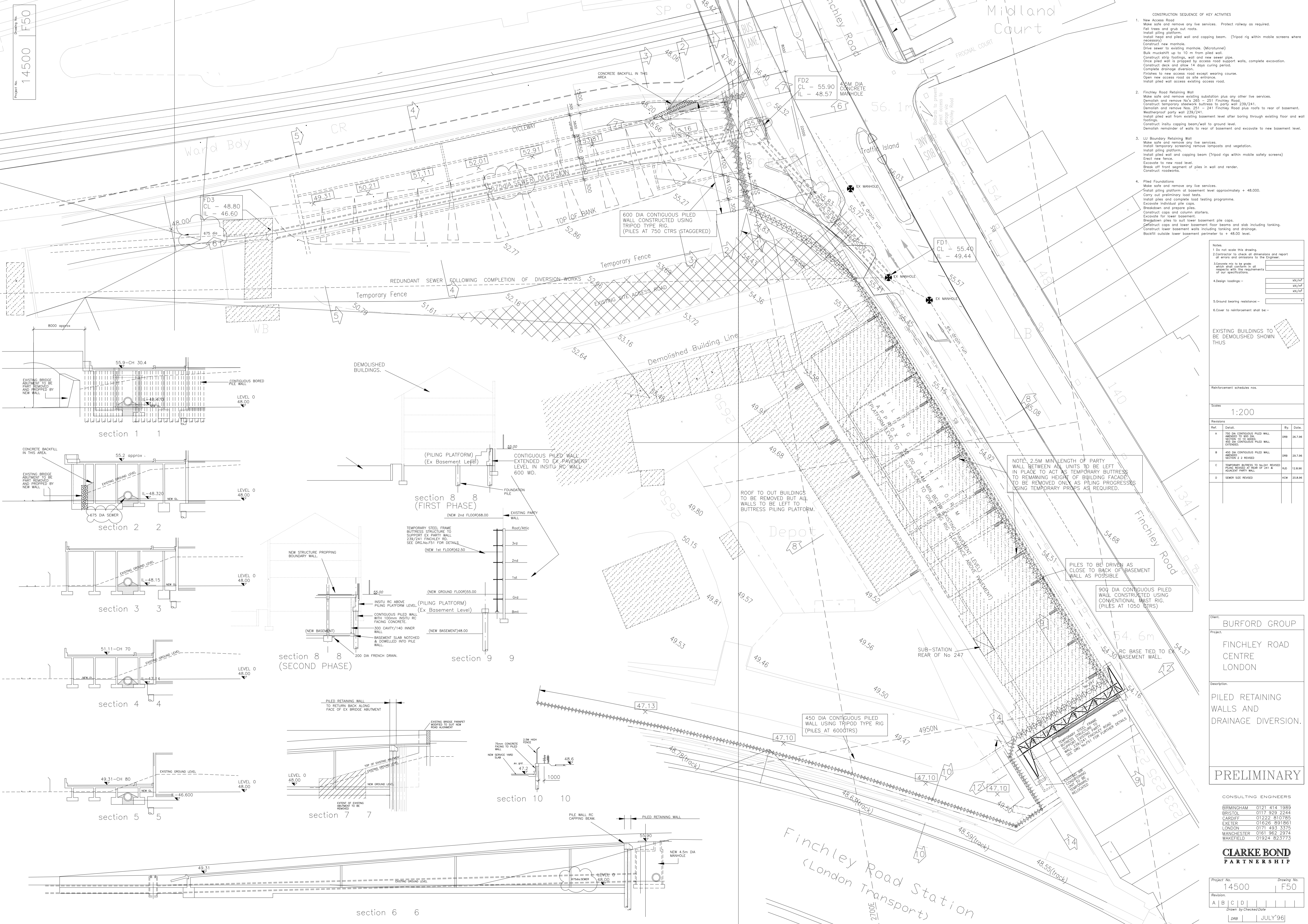

- CONSTRUCTION SEQUENCE OF KEY ACTIVITIES**
- New Access Road**
Make safe and remove any live services. Protect railway as required.
Fall trees and grub out roots.
Install piling platform.
Install head end piled wall and capping beam. (Tripod rig within mobile screens where necessary).
Construct new manhole.
Drive sewer to existing manhole. (Microtunnel).
Bulk muckshift up to 10 m from piled wall.
Construct strip footings, wall and new sewer pipe.
Once piled wall is propped by access road support walls, complete excavation.
Construct deck and allow 14 days curing period.
Complete drainage diversion.
Finish to new access road except wearing course.
Open new access road as site entrance.
Install piled wall access existing access road.
 - Finchley Road Retaining Wall**
Make safe and remove existing substation plus any other live services.
Demolish and remove Nos 265 - 251 Finchley Road.
Construct temporary steelwork buttress to party wall 239/241.
Demolish and remove Nos. 251 - 241 Finchley Road plus roofs to rear of basement.
Install piled wall from existing basement level after boxing through existing floor and wall footings.
Construct in situ capping beam/wall to ground level.
Demolish remainder of walls to rear of basement and excavate to new basement level.
 - LU Boundary Retaining Wall**
Make safe and remove any live services.
Install temporary screening remove lampposts and vegetation.
Install piling platform.
Install piled wall and capping beam (Tripod rigs within mobile safety screens).
Erect new fence.
Excavate to new road level.
Break off front segment of piles in wall and render.
Construct roadworks.
 - Piled Foundations**
Make safe and remove any live services.
Install piling platform at basement level approximately +48.000.
Carry out preliminary load tests.
Excavate individual pile caps.
Breakdown and prepare piles.
Construct caps and column starters.
Excavate for lower basement.
Breakdown piles to suit lower basement pile caps.
Construct caps and lower basement floor beams and slab including tanking.
Construct lower basement walls including tanking and drainage.
Backfill outside lower basement perimeter to +48.000 level.

Notes

- Do not scale this drawing.
- Consultor to check all dimensions and report of errors and omissions to the Engineer.
- Concrete mix to be given which shall conform to all aspects with the requirements of our specifications.
- Design loadings: -
- Ground bearing resistance: -
- Cover to reinforcement shall be -

EXISTING BUILDINGS TO BE DEMOLISHED SHOWN THUS

Reinforcement schedules nos.

Scales: 1:200

Revisions

Ref.	Detail	By	Date
A	750 DIA CONTIGUOUS PILED WALL EXTENDED TO 900 DIA SECTION 10 TO ACCESS CONTIGUOUS PILED WALL EXTENDED.	DB	24.7.96
B	400 DIA CONTIGUOUS PILED WALL SECTION 2 REVISED	DB	29.7.96
C	TEMPORARY BUTTRESS TO IN-241 REVISIONS ABOVE REVISED REAR OF 241 W	AD	12.8.96
D	SEWER SIZE REVISED	HW	20.8.96

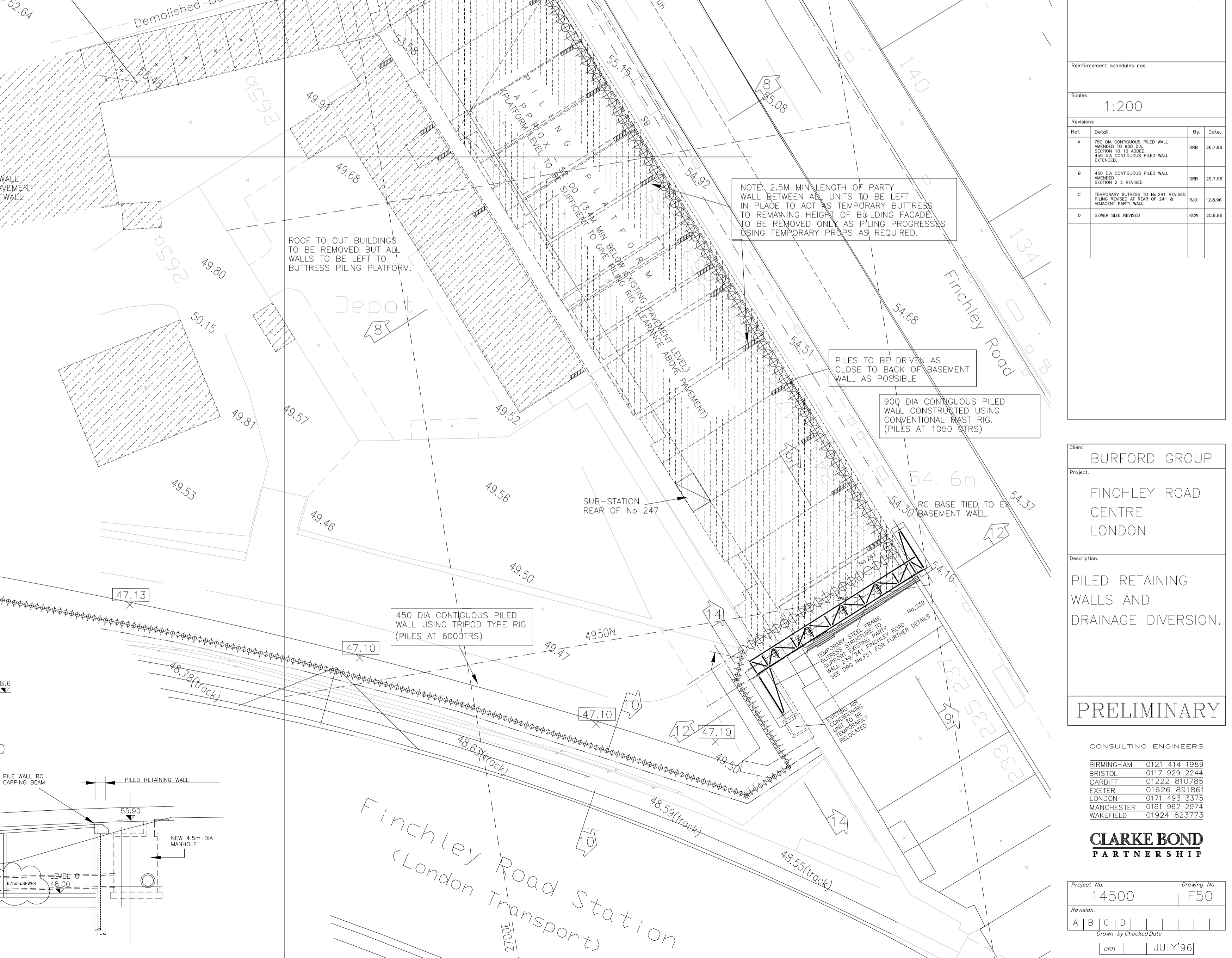
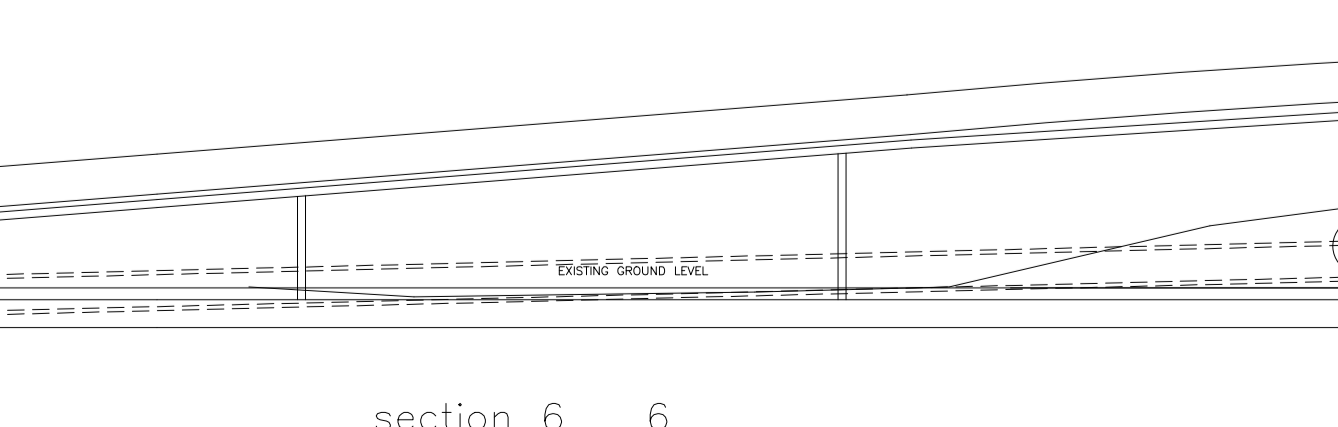
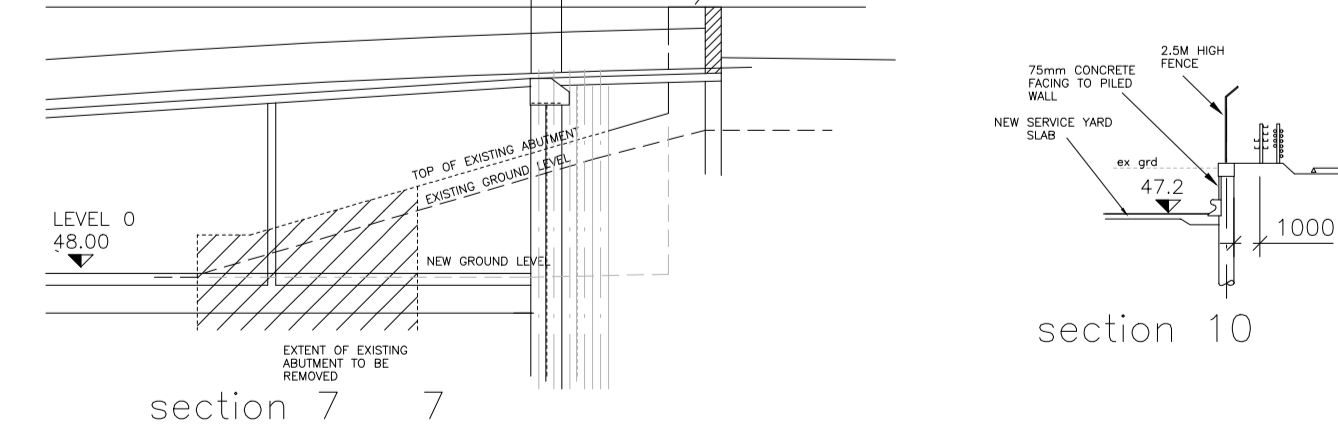
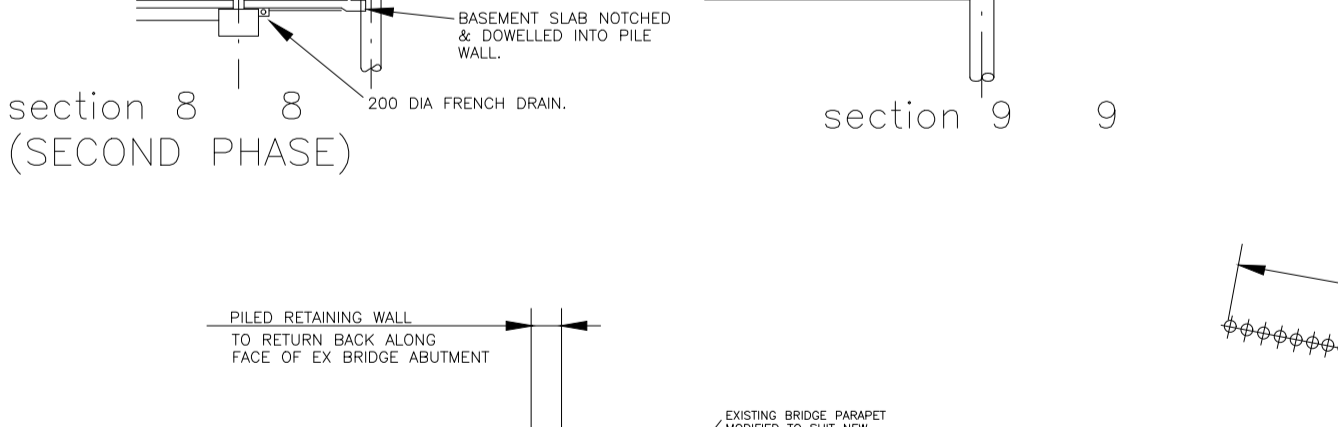
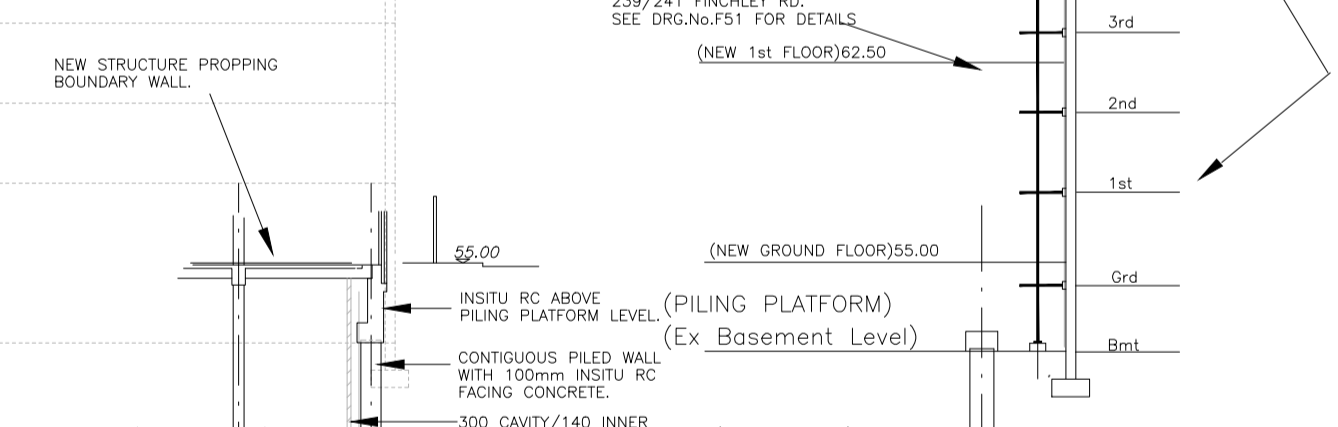
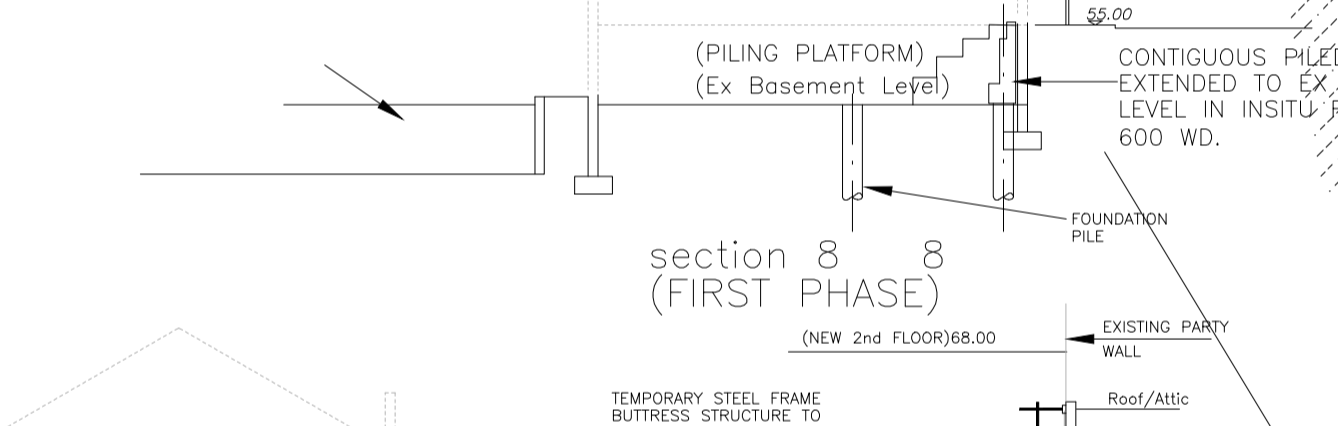
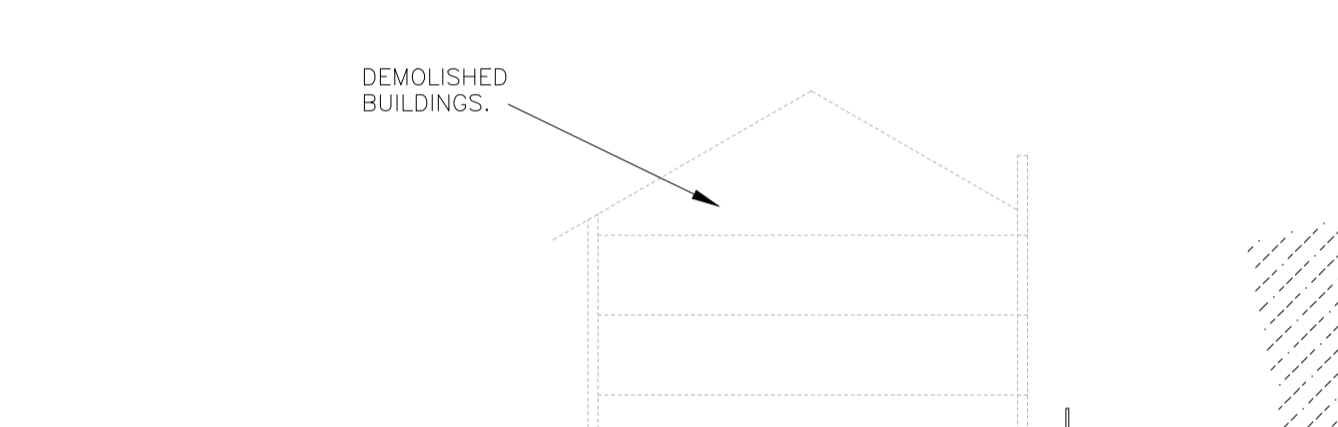
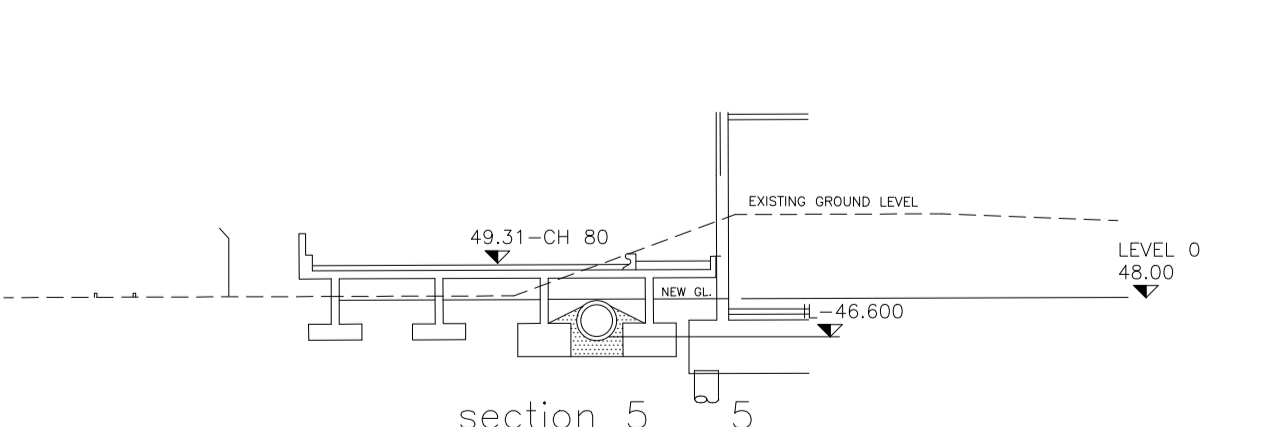
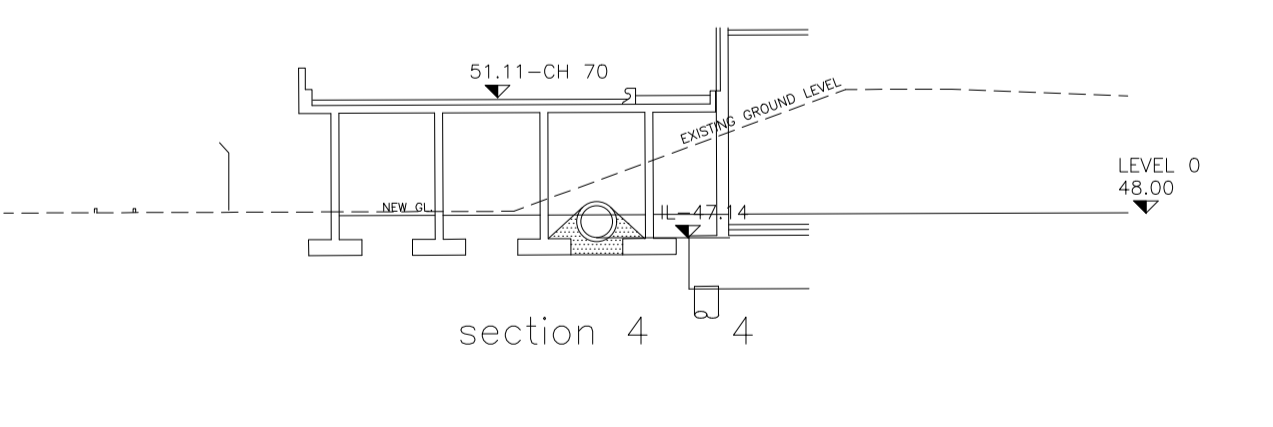
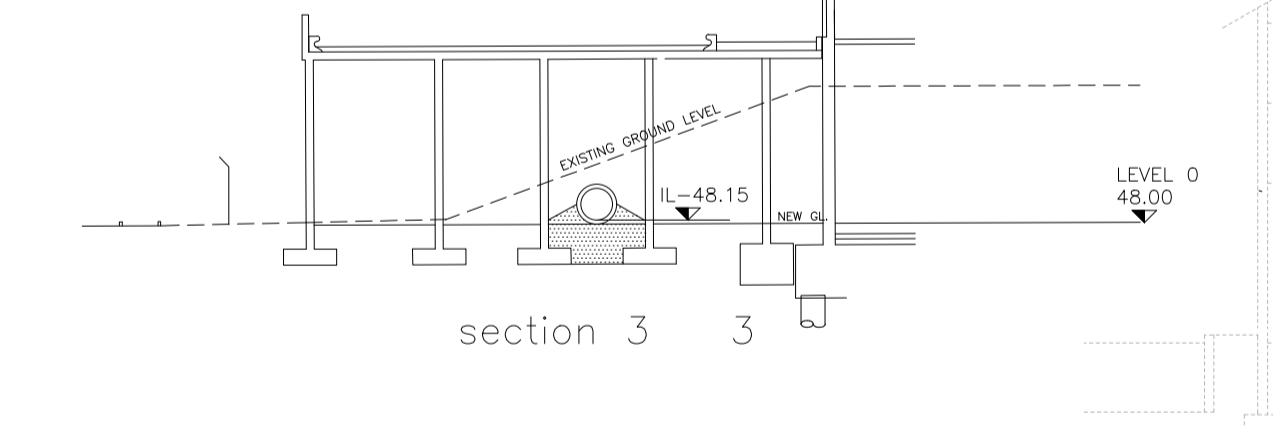
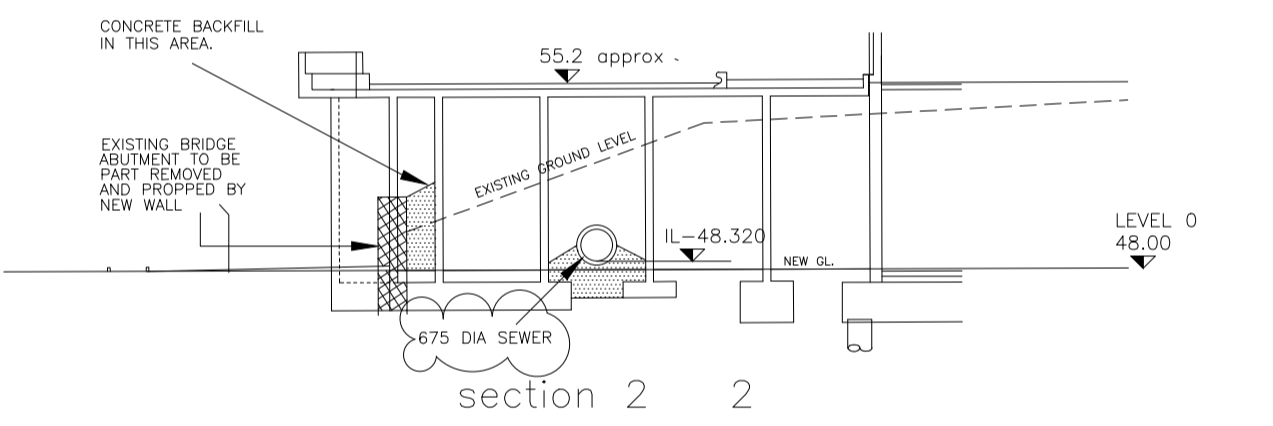
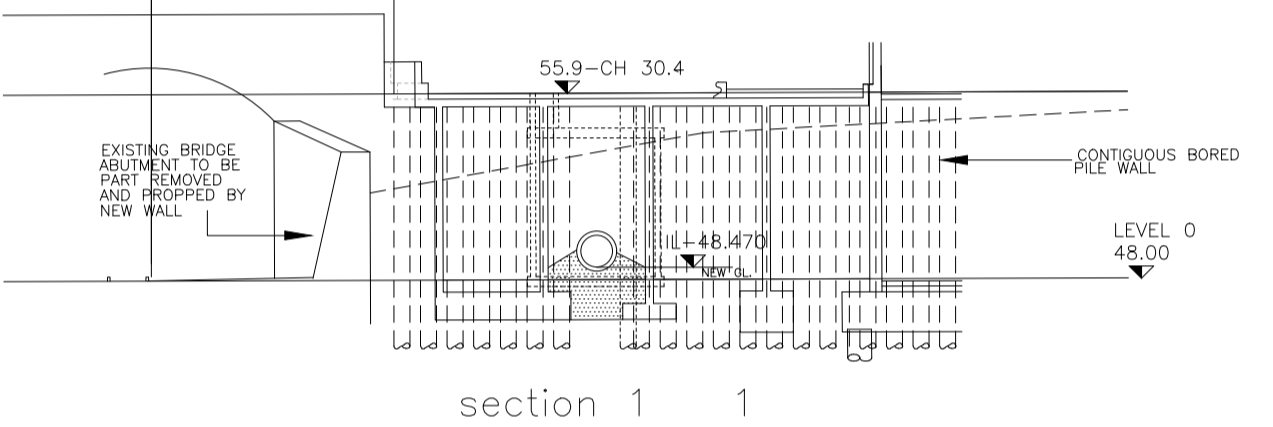

Client: **BURFORD GROUP**

Project: **FINCHLEY ROAD CENTRE LONDON**

Description: **PILED RETAINING WALLS AND DRAINAGE DIVERSION.**

PRELIMINARY

CONSULTING ENGINEERS

BIRMINGHAM 0121 414 1989
 BRISTOL 0117 929 2244
 CARDIFF 01222 810785
 EXETER 01326 591861
 LONDON 0171 493 3375
 MANCHESTER 0161 962 2974
 WAKEFIELD 01924 823773

CLARKE BOND PARTNERSHIP

Notes:
 1.30: not scale this drawing
 2. Contractor to check all dimensions and report all errors and omissions to the Engineer.
 3. Concrete mix to be grade [See Note 6] which shall conform in all respects with the requirements of our specifications.
 4. Design loadings:-
 5. Ground bearing resistance:-
 6. For Concrete Mass see Specification E10 - Clauses 120, 126 & 128

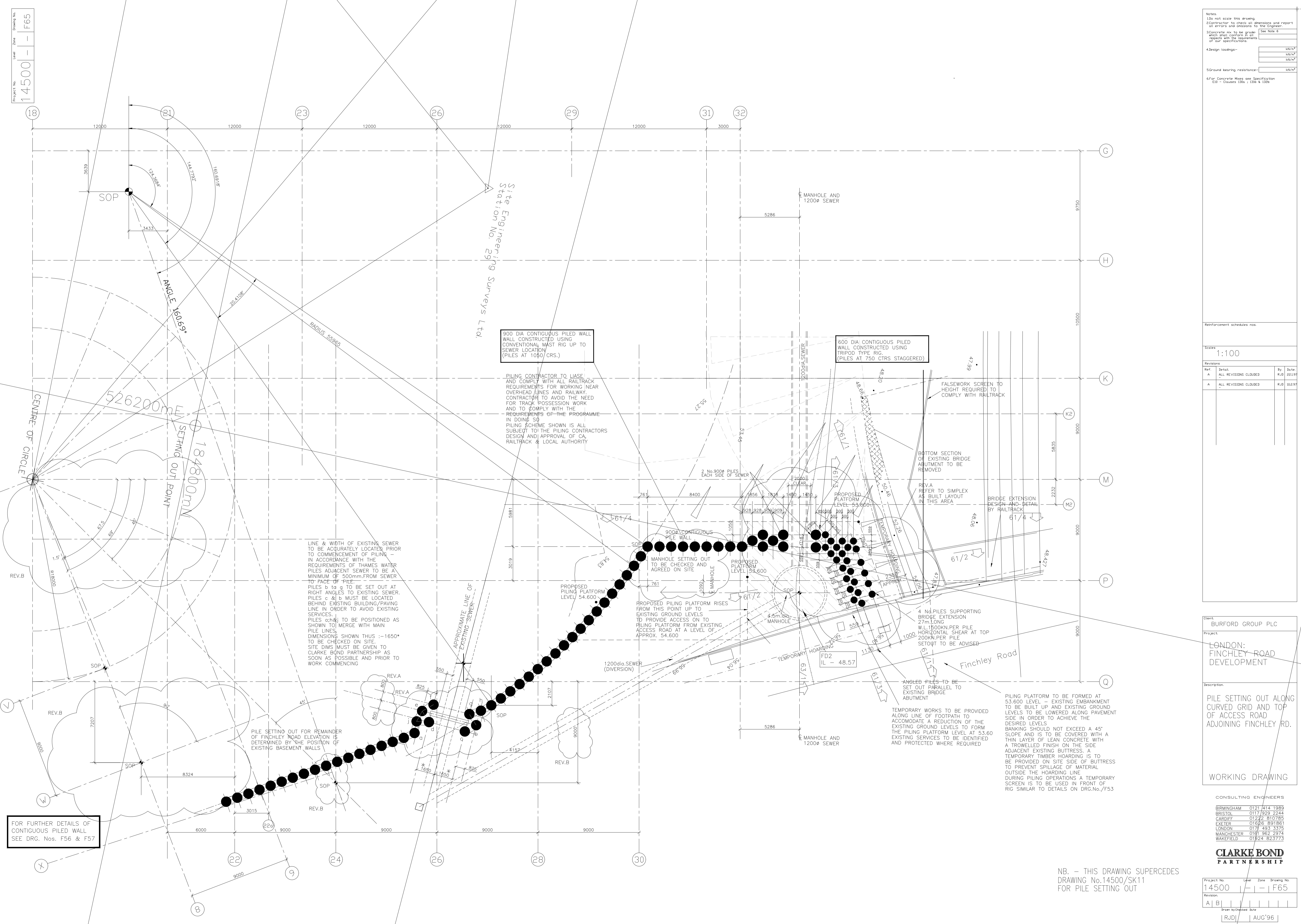

900 DIA CONTIGUOUS PILED WALL CONSTRUCTED USING CONVENTIONAL MAST RIG UP TO SEWER LOCATION (PILES AT 1050 CRS.)

600 DIA CONTIGUOUS PILED WALL CONSTRUCTED USING TRIPOD TYPE RIG. (PILES AT 750 CTRS STAGGERED)

PILING CONTRACTOR TO LIASE AND COMPLY WITH ALL RAILTRACK REQUIREMENTS FOR WORKING NEAR OVERHEAD LINES AND RAILWAY. CONTRACTOR TO AVOID THE NEED FOR TRACK POSSESSION WORK AND TO COMPLY WITH THE REQUIREMENTS OF THE PROGRAMME IN DOING SO. PILING SCHEME SHOWN IS ALL SUBJECT TO THE PILING CONTRACTORS DESIGN AND APPROVAL OF CA, RAILTRACK & LOCAL AUTHORITY

LINE & WIDTH OF EXISTING SEWER TO BE ACCURATELY LOCATED PRIOR TO COMMENCEMENT OF PILING - IN ACCORDANCE WITH THE REQUIREMENTS OF THAMES WATER PILES ADJACENT SEWER TO BE A MINIMUM OF 500mm FROM SEWER TO FACE OF PILE. PILES b to g TO BE SET OUT AT RIGHT ANGLES TO EXISTING SEWER. PILES c & b MUST BE LOCATED BEHIND EXISTING BUILDING/PAVING LINE IN ORDER TO AVOID EXISTING SERVICES. PILES a-h TO BE POSITIONED AS SHOWN TO MERGE WITH MAIN PILE LINE. DIMENSIONS SHOWN THUS -1650* TO BE CHECKED ON SITE. SITE DIMS MUST BE GIVEN TO CLARKE BOND PARTNERSHIP AS SOON AS POSSIBLE AND PRIOR TO WORK COMMENCING

FOR FURTHER DETAILS OF CONTIGUOUS PILED WALL SEE DRG. Nos. F56 & F57

PILE SETTING OUT ALONG CURVED GRID AND TOP OF ACCESS ROAD ADJOINING FINCHLEY RD.

PILING PLATFORM TO BE FORMED AT 53.600 LEVEL - EXISTING EMBANKMENT TO BE BUILT UP AND EXISTING GROUND LEVELS TO BE LOWERED ALONG PAVEMENT SIDE IN ORDER TO ACHIEVE THE DESIRED LEVELS. BANKING SHOULD NOT EXCEED A 45° SLOPE AND IS TO BE COVERED WITH A THIN LAYER OF LEAN CONCRETE WITH A TROWELLED FINISH ON THE SIDE ADJACENT EXISTING BUTTRESS. A TEMPORARY TIMBER HOARDING IS TO BE PROVIDED ON SITE SIDE OF BUTTRESS TO PREVENT SPILLAGE OF MATERIAL OUTSIDE THE HOARDING LINE DURING PILING OPERATIONS. A TEMPORARY SCREEN IS TO BE USED IN FRONT OF RIG SIMILAR TO DETAILS ON DRG.No./F53

Reinforcement schedules nos

Scales 1:100

Rev.	Detail	By	Date
A	ALL REVISIONS CLOUED	RJD	22/3/97
A	ALL REVISIONS CLOUED	RJD	10/2/97

Client: BURFORD GROUP PLC
 Project: LONDON: FINCHLEY ROAD DEVELOPMENT
 Description: PILE SETTING OUT ALONG CURVED GRID AND TOP OF ACCESS ROAD ADJOINING FINCHLEY RD.

WORKING DRAWING

CONSULTING ENGINEERS
 BIRMINGHAM 0121 414 1989
 BRISTOL 0117 929 2244
 CARDIFF 01222 810785
 EXETER 01392 891861
 LONDON 0171 493 3375
 MANCHESTER 0161 962 2974
 WAKEFIELD 01924 823773

CLARKE BOND PARTNERSHIP

NB. - THIS DRAWING SUPERCEDES DRAWING No.14500/SK11 FOR PILE SETTING OUT

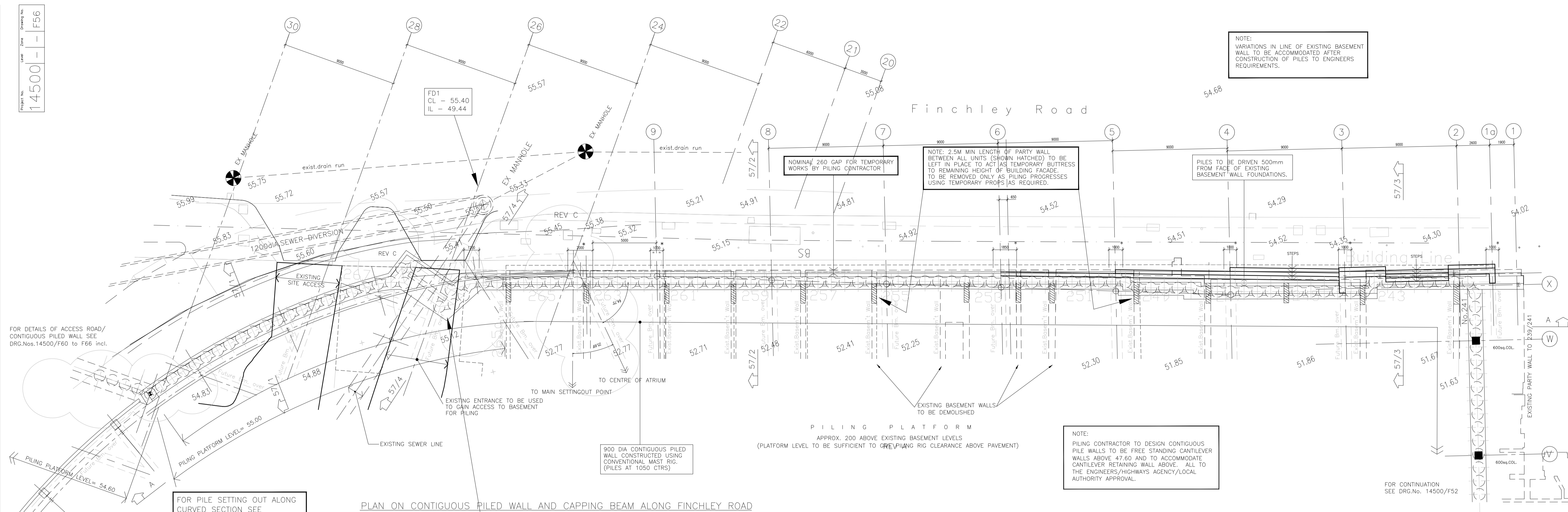

FOR DETAILS OF ACCESS ROAD/
 CONTIGUOUS PILED WALL SEE
 DRG. Nos. 14500/F60 to F66 incl.

FOR PILE SETTING OUT ALONG
 CURVED SECTION SEE
 DRG. NO. 14500/F65

PLAN ON CONTIGUOUS PILED WALL AND CAPPING BEAM ALONG FINCHLEY ROAD

LEGEND:
 EGL = Exist. Ground Level
 EBL = Exist. Basement Level

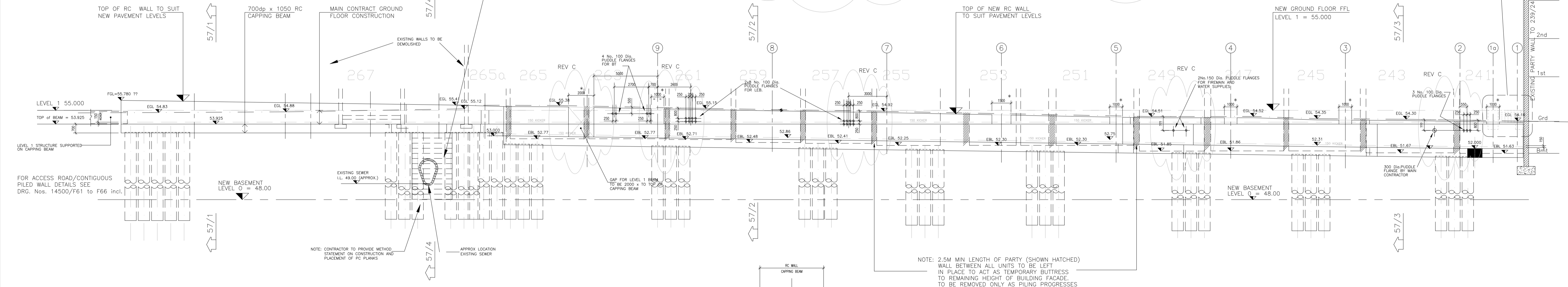

ELEVATION A - A (LOOKING TOWARDS FINCHLEY ROAD)

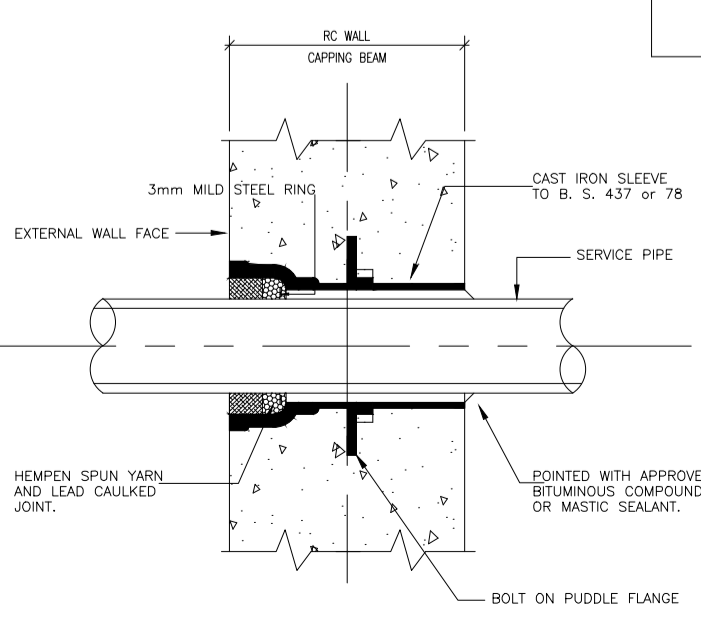

TYPICAL PUDDLE FLANGE DETAIL
 (SCALE 1:5)

NOTE:
 VARIATIONS IN LINE OF EXISTING BASEMENT
 WALL TO BE ACCOMMODATED AFTER
 CONSTRUCTION OF PILES TO ENGINEERS
 REQUIREMENTS.

NOMINAL 260 GAP FOR TEMPORARY
 WORKS BY PILING CONTRACTOR

NOTE: 2.5M MIN LENGTH OF PARTY WALL
 BETWEEN ALL UNITS (SHOWN HATCHED) TO BE
 LEFT IN PLACE TO ACT AS TEMPORARY BUTTRESS
 TO REMAINING HEIGHT OF BUILDING FACADE.
 TO BE REMOVED ONLY AS PILING PROGRESSES
 USING TEMPORARY PROPS AS REQUIRED.

PILES TO BE DRIVEN 500mm
 FROM FACE OF EXISTING
 BASEMENT WALL FOUNDATIONS.

NOTE:
 PILING CONTRACTOR TO DESIGN CONTIGUOUS
 PILE WALLS TO BE FREE STANDING CANTILEVER
 WALLS ABOVE 47.60 AND TO ACCOMMODATE
 CANTILEVER RETAINING WALL ABOVE. ALL TO
 THE ENGINEERS/HIGHWAYS AGENCY/LOCAL
 AUTHORITY APPROVAL.

N.B. 250 RETAINING WALL TO BE CAST TO UNDERSIDE LEVEL 1 SLAB - 54.400
 DENOTED THUS ON ELEVATION - - - - - (EXCEPT SECTION BETWEEN
 GRIDS 1 and 4 - 54.075 KICKER LEVEL).
 REMAINDER CAST WITH LEVEL 1 STRUCTURE BY MAIN CONTRACTOR

* DENOTES MINIMUM GAP TO BE LEFT IN 250 RETAINING
 WALL FOR FUTURE LEVEL 1 GROUND FLOOR BEAMS
 BY MAIN CONTRACTOR. (FOR LOCATION/SETTING DETAILS
 REFER TO DRG. Nos. 14500/G16, G17, G56 & G57)

RECESS/GAP IN WALL TO ACCOMMODATE
 FUTURE LEVEL 1 BEAMS / ENTRANCE
 STAIRCASE IJ
 SEE DRG. No. G17 FOR DETAILS

FOR SECTIONS/DETAILS SEE
 DRG. NO. 14500/F57

FOR REINFORCEMENT DETAILS
 SEE DRG. NO. 14500/F59

Notes

- Do not scale this drawing.
- Contractor to check dimensions and report all errors and omissions to the Engineer.
- Contractor to be given which shall comply with the requirements of our specifications.
- Design loadings -
- Ground bearing resistance -
- For Concrete mixes see specification E10 classes 130s, 131s & 132s
- Cover to reinforcement shall be -

Reinforcement schedules nos.

Scales: 1:100

Revisions

Rev.	Description	By	Date
T1	TENDER ISSUE - TO QS	BC	09.08
T2	TENDER ISSUE	BC	12.06
A	CONTIGUOUS PILED WALL REVISION TO SFT BASEMENT WALL SURVEY (COVER BEAM REVISION)	BC	22.11.09
B	WALL MOVED NOW 200 FROM FINCHLEY ROAD (SEE REVISIONS) REVISION REQUIRED DUE TO SFT PILE LOADS (REINFORCEMENT DETAILS REVISED AND ADDED TO DRG. No. F58)	BC	12.12.09
C	REVISION PILED WALL REVISION ADDED PILES ADJACENT TO EXISTING SFT WALL (SEE REVISIONS) REVISION REQUIRED TO SFT COVER BEAM REVISION TO SFT OTHER REVISIONS SHOW (SEE DRG. No. F59)	BC	10.02.10

Client: BURFORD GROUP PLC

Project: LONDON: FINCHLEY ROAD DEVELOPMENT

Description: G.A. CONTIGUOUS PILED WALL/CAPPING BEAM ALONG FINCHLEY ROAD

For Construction Enabling Works

Consulting Engineers:

BIRMINGHAM	0121 414 1989
BRISTOL	0117 929 2244
CARDIFF	01222 810785
EXETER	01392 891961
LONDON	0171 255 1998
MANCHESTER	0161 962 2974
WAKEFIELD	01924 823773

CLARKE BOND PARTNERSHIP

Project No. 14500 - F56
 Drawing No. F56
 A | B | C | D | E | F | G | H | I | J | K | L | M | N | O | P | Q | R | S | T | U | V | W | X | Y | Z
 Drawn by: [] Date: []

