

WINDOW TYPES 14, 15
Ground Floor Roger Street Extension
Elevation and Section

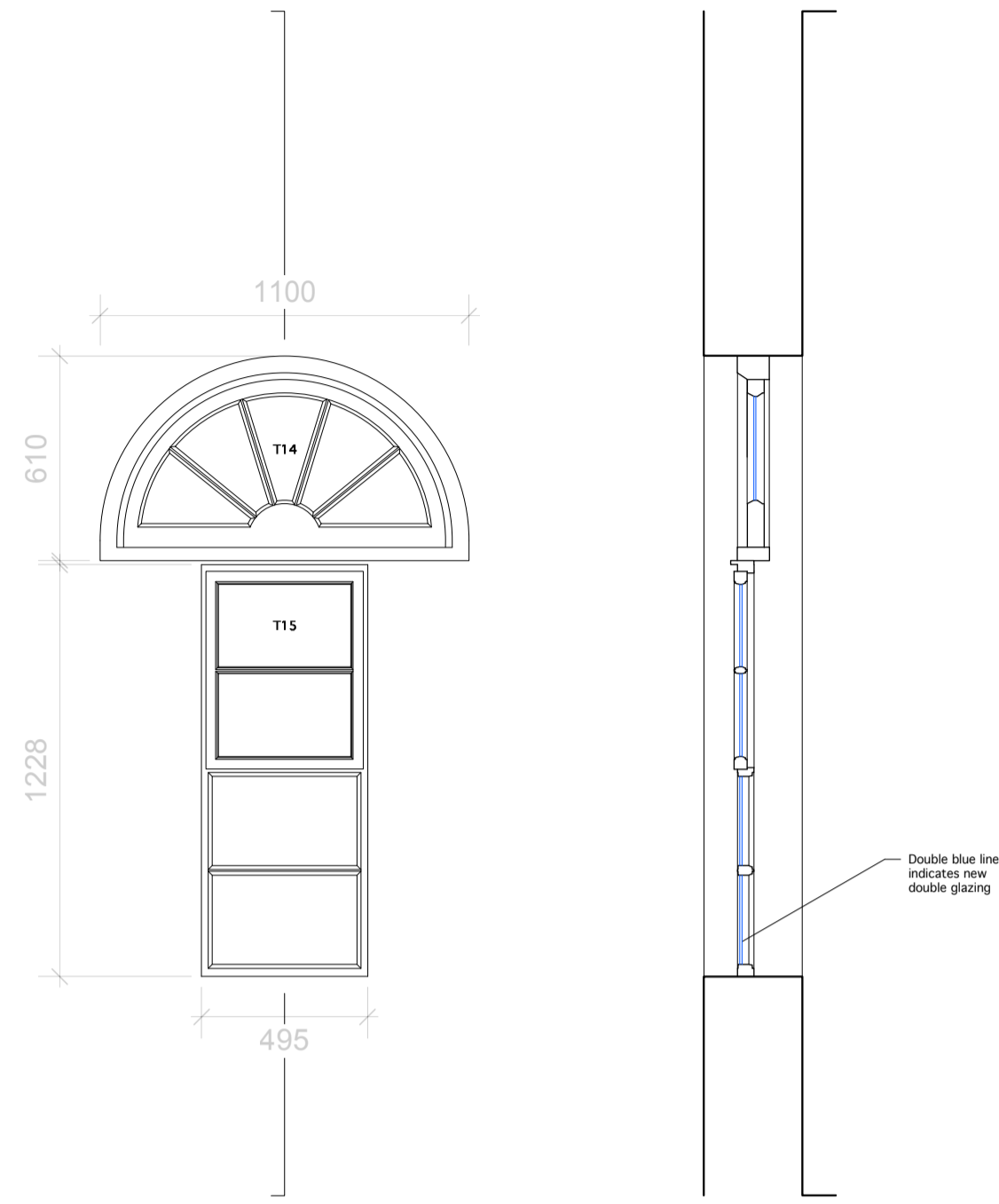

WINDOW TYPE 16
Ground Floor
Elevation and Section

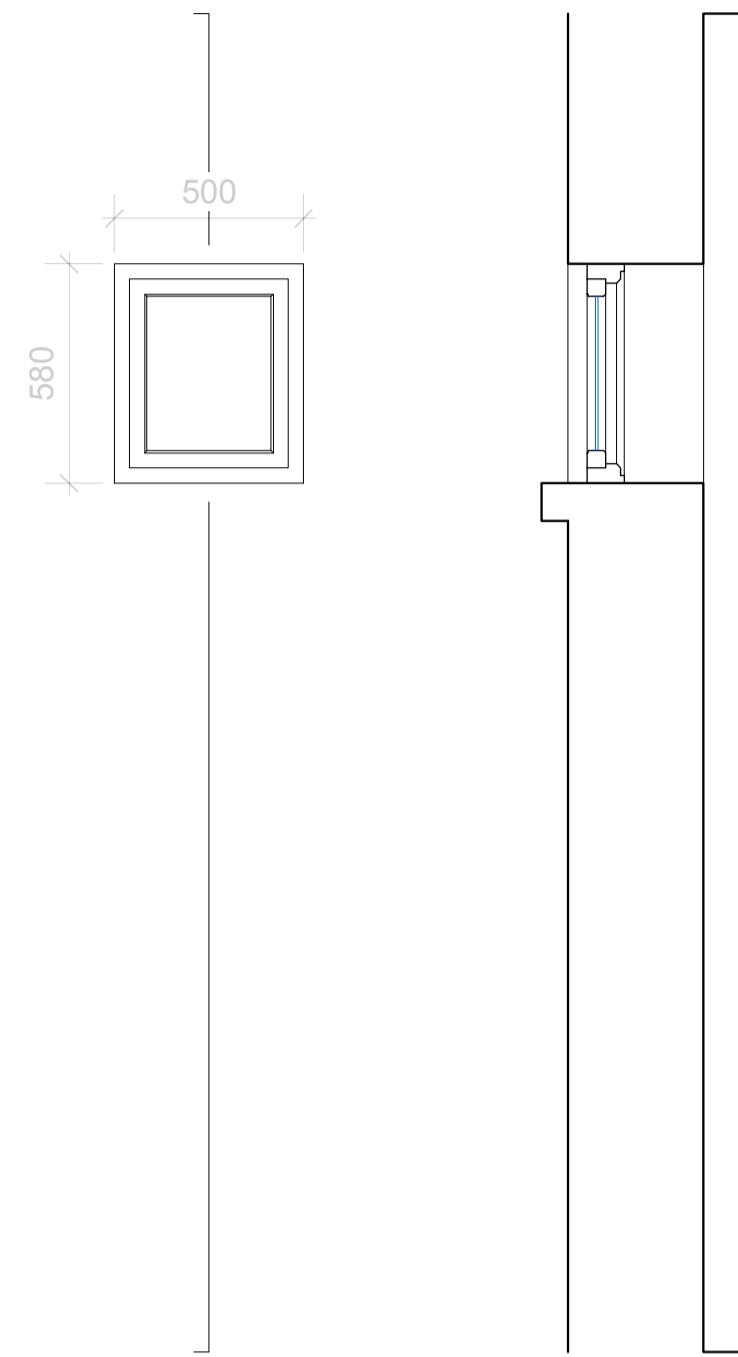

WINDOW TYPE 17
First Floor
Elevation and Section

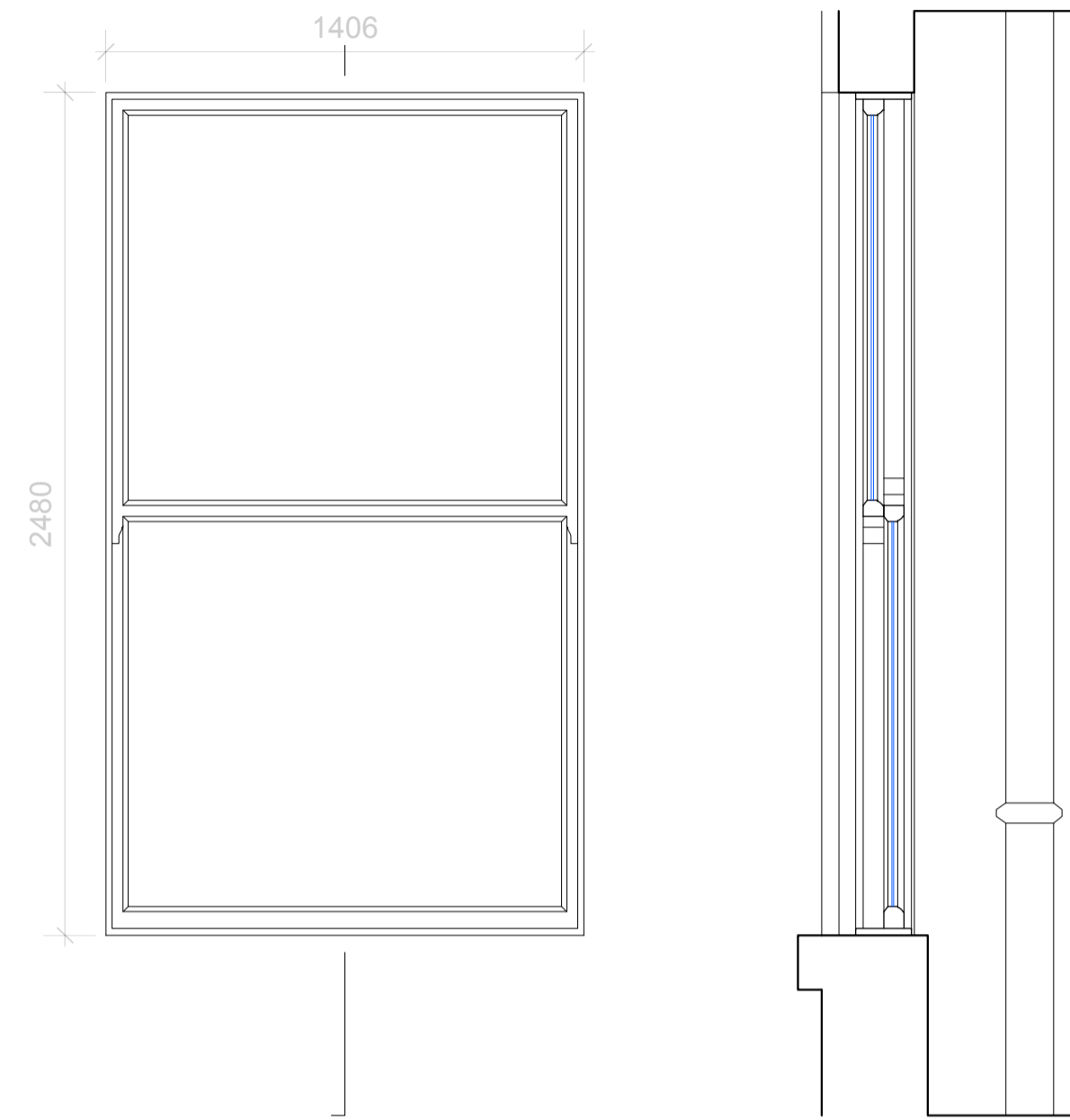

WINDOW TYPE 19
First Floor
Elevation and Section

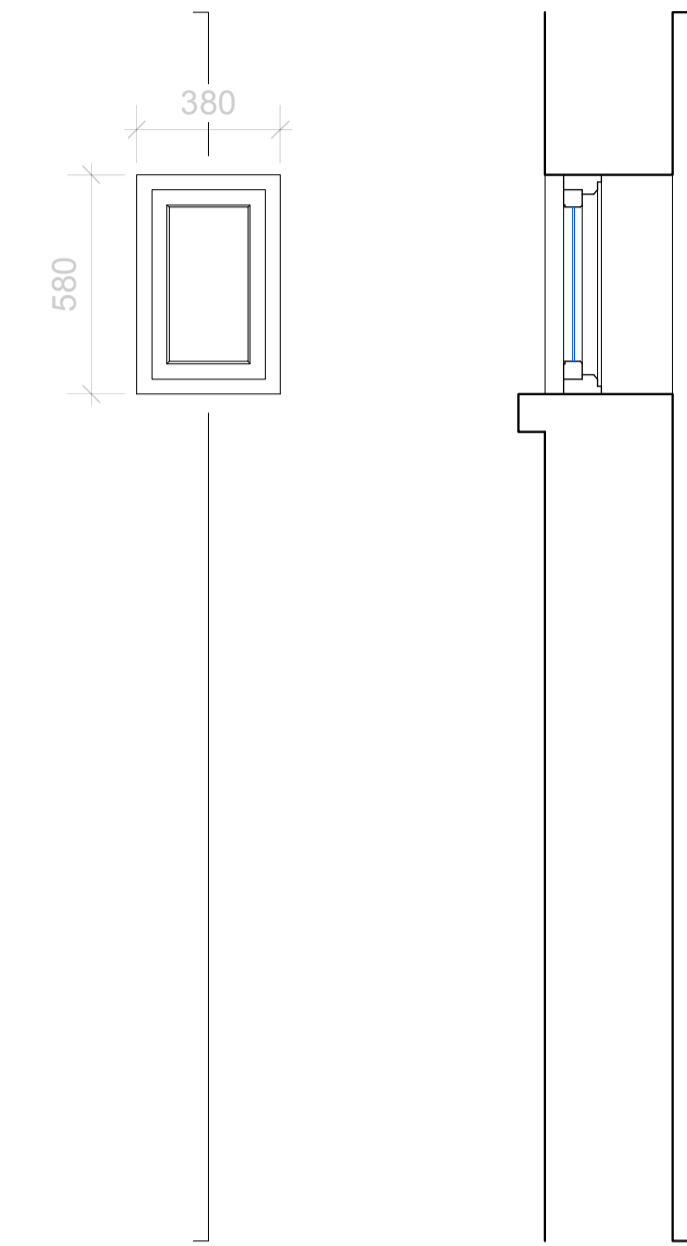

WINDOW TYPE 20
First Floor
Elevation and Section

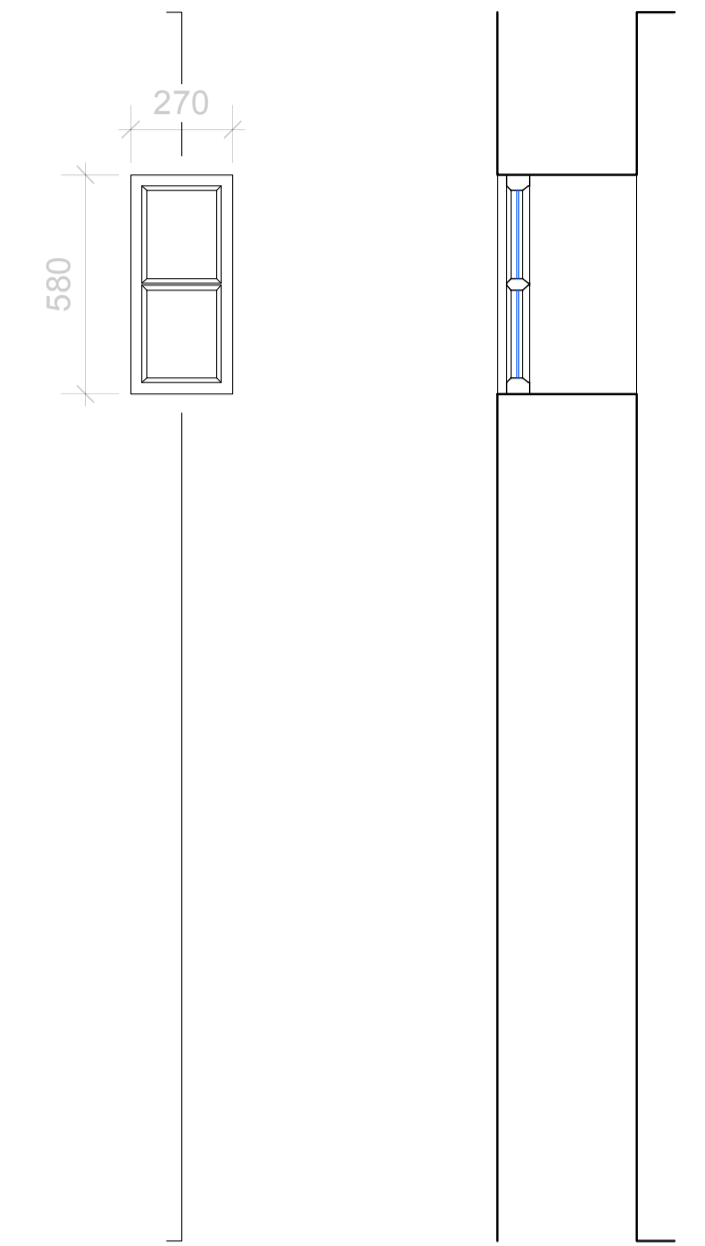

WINDOW TYPE 18
Ground Floor to First Floor Stairwell
Elevation and Section

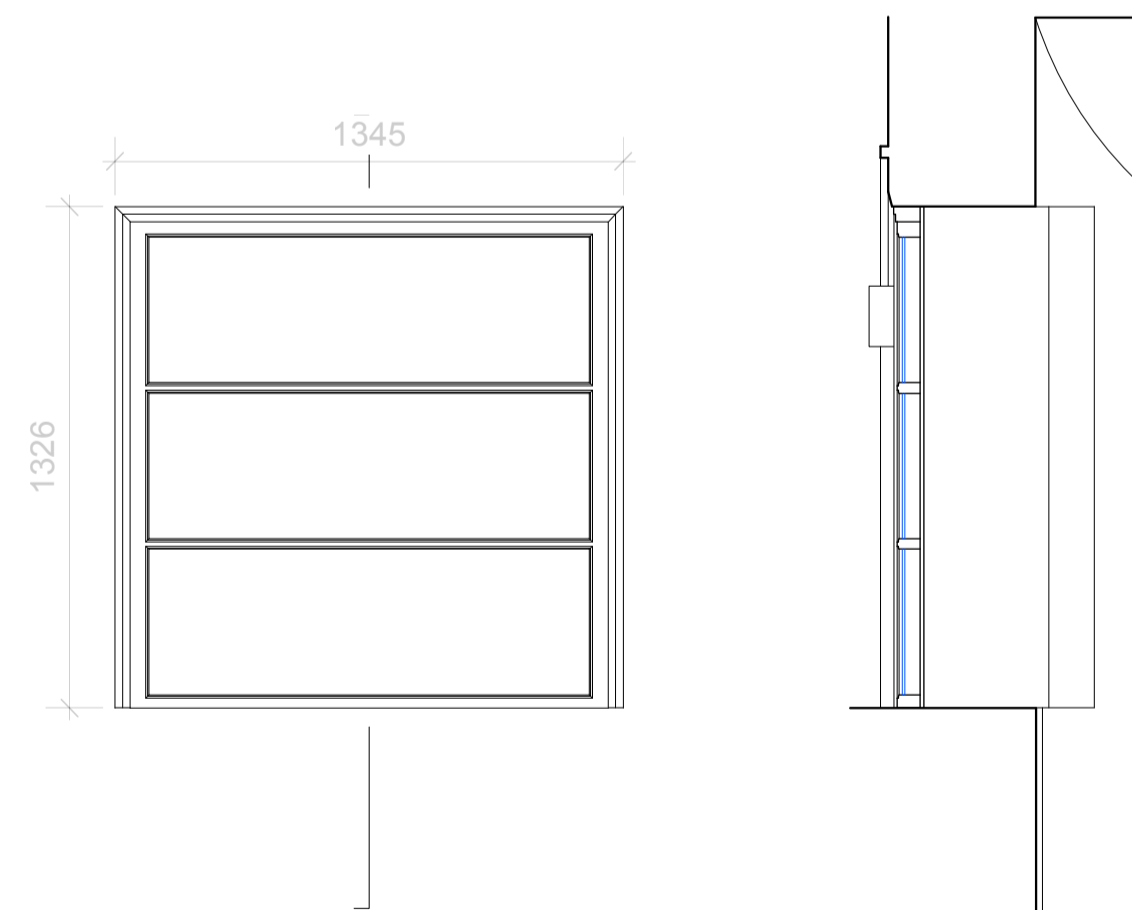

WINDOW TYPE 21
First Floor
Elevation and Section

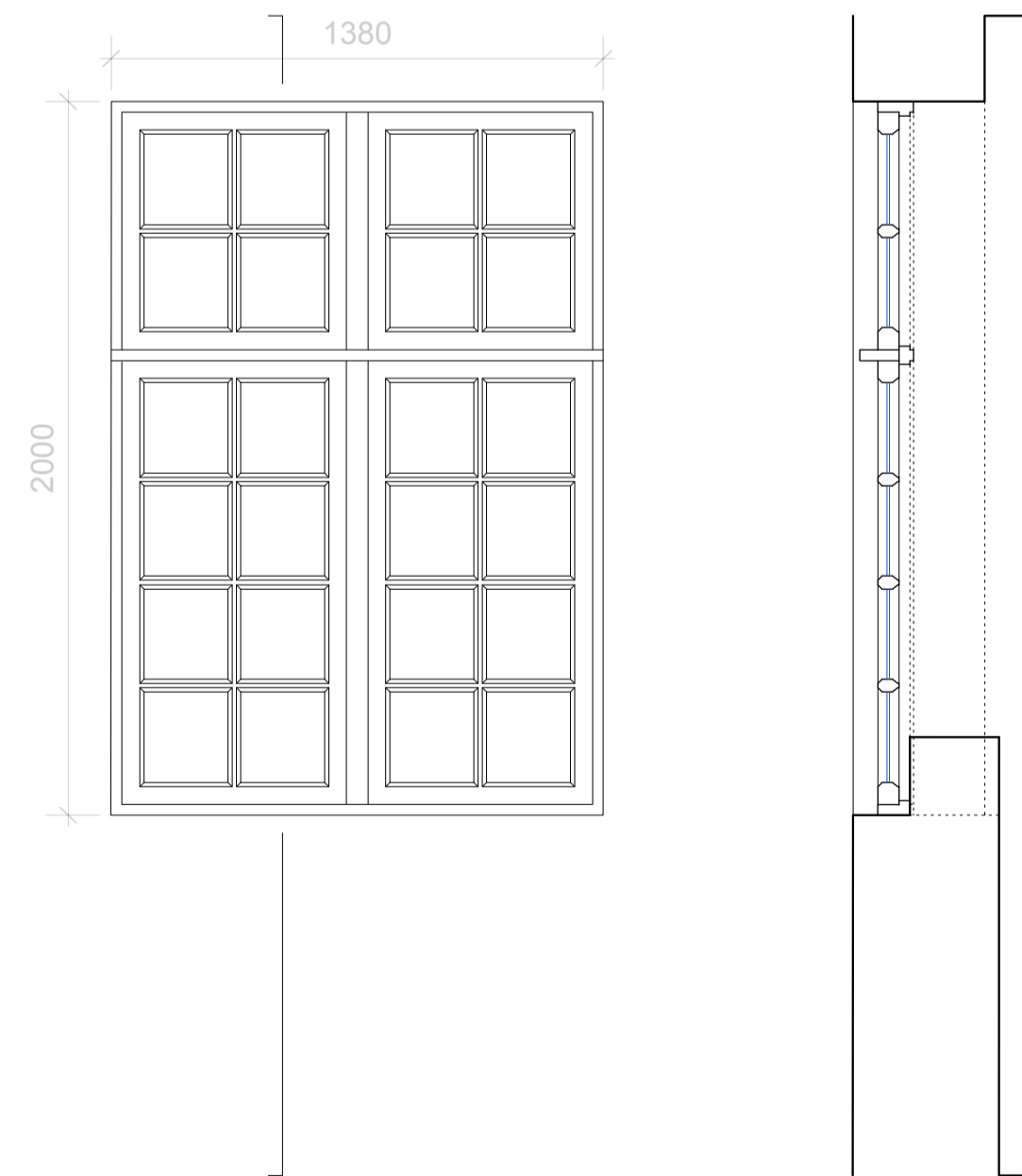

WINDOW TYPE 22
First Floor
Elevation and Section

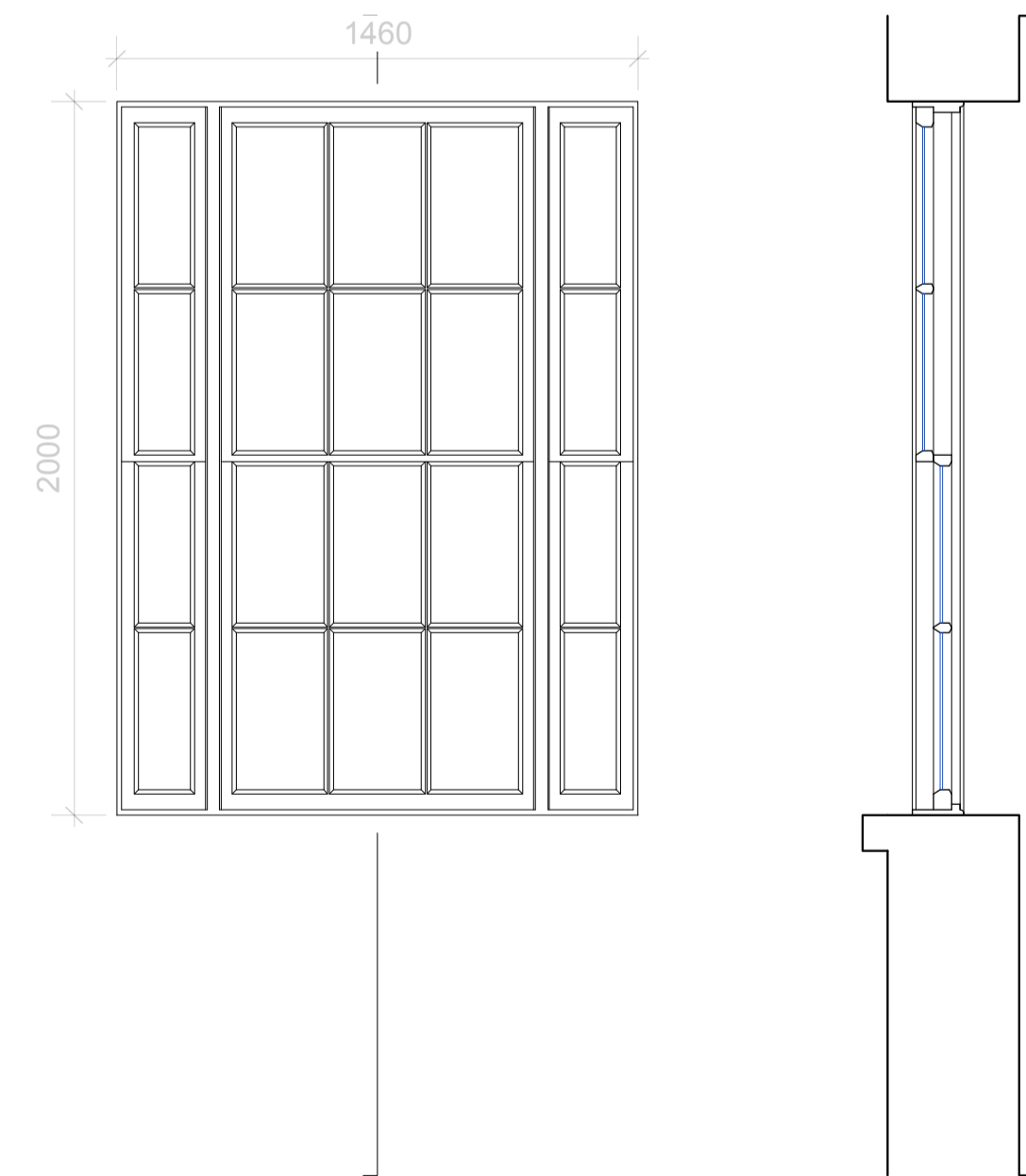

WINDOW TYPE 23
Second Floor
Elevation and Section

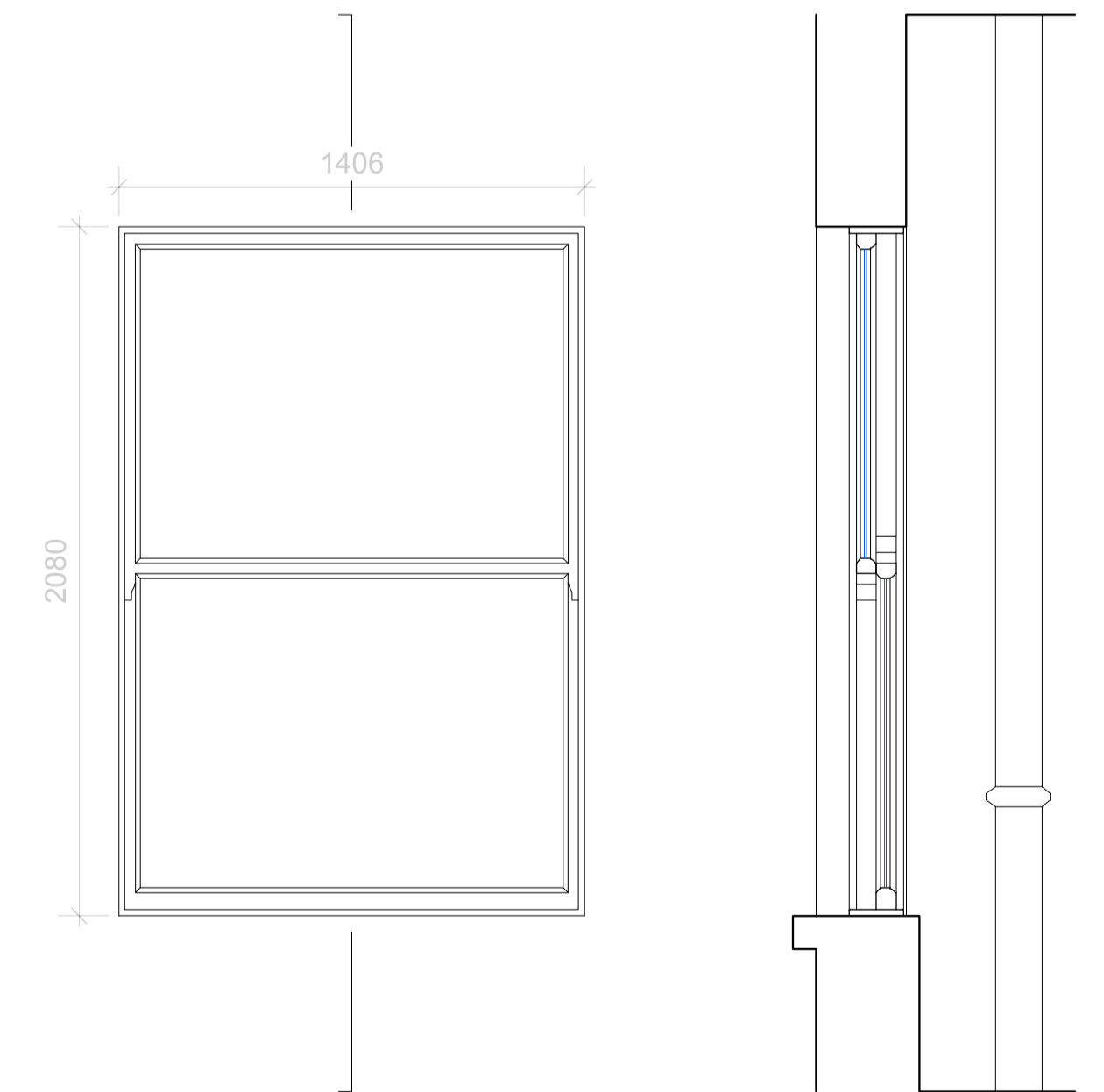

burrell&mistry

7a Lamb's Conduit Passage, London, WC1R 4RG, UK T: +44(0)20 7092 3081/82 E: post@burrellmistry.com

| | | | | | | | | |
|--|---|------|------|----------------------|---------------------------------|--|------------------------|-------------------------------|
| <p>General Notes:</p> <p>All dimensions to be checked on site. All dimensions in mm. DO NOT SCALE drawing. Burrell & Mistry Ltd. is a limited company registered in the UK. © All drawings and designs remain the copyright of Burrell & Mistry Ltd.</p> | <p>Drawing to be read in conjunction with all contract documents. Verify all existing conditions and dimensions on site. If in doubt, the contractor is to seek the advice of the employer's representative, site architect and engineer.</p> | Rev. | Chk. | Revision Description | Project Title Doughty Street | Site Address 1 Doughty Street, London WC1N 2PH | Client | |
| | | | | | | Drawing Title Proposed Reveal/Window Frame Placements, Window Types 14-23 | Project Number 1218 | Drawing Number 1218/1009/2 |
| | | | | | | Scale 1:20 @ A1 | Date 12/08/21 | Drawn By IT |