

SECTIONS (Scale 1:2)

Section A-A - Top Sash Jamb

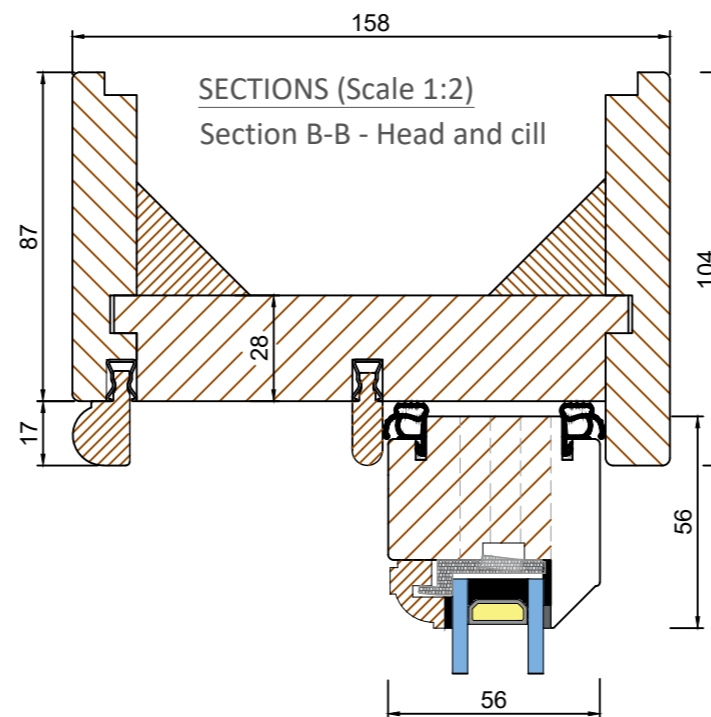

SECTIONS (Scale 1:2)
Section C-C - Bottom Sash Jamb

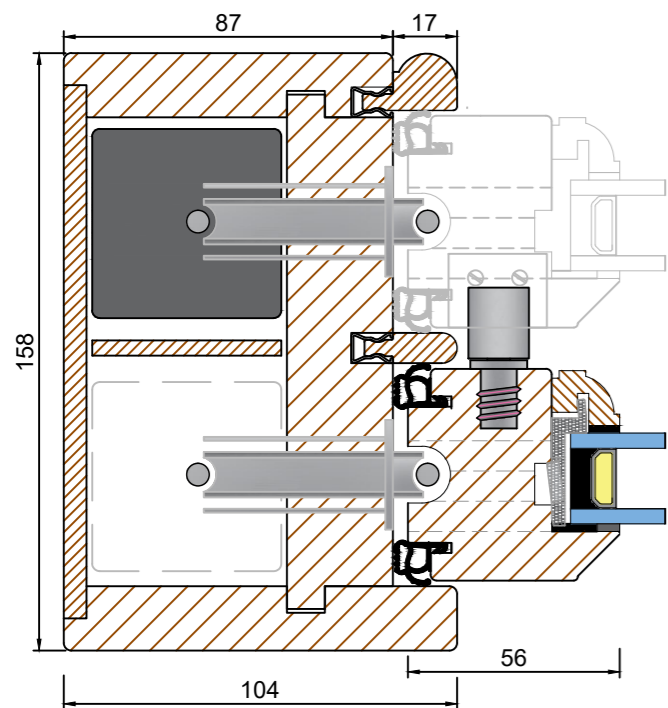
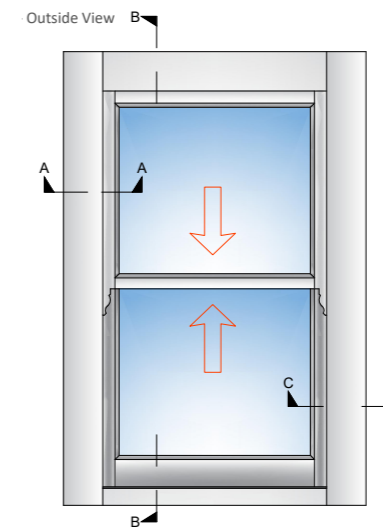
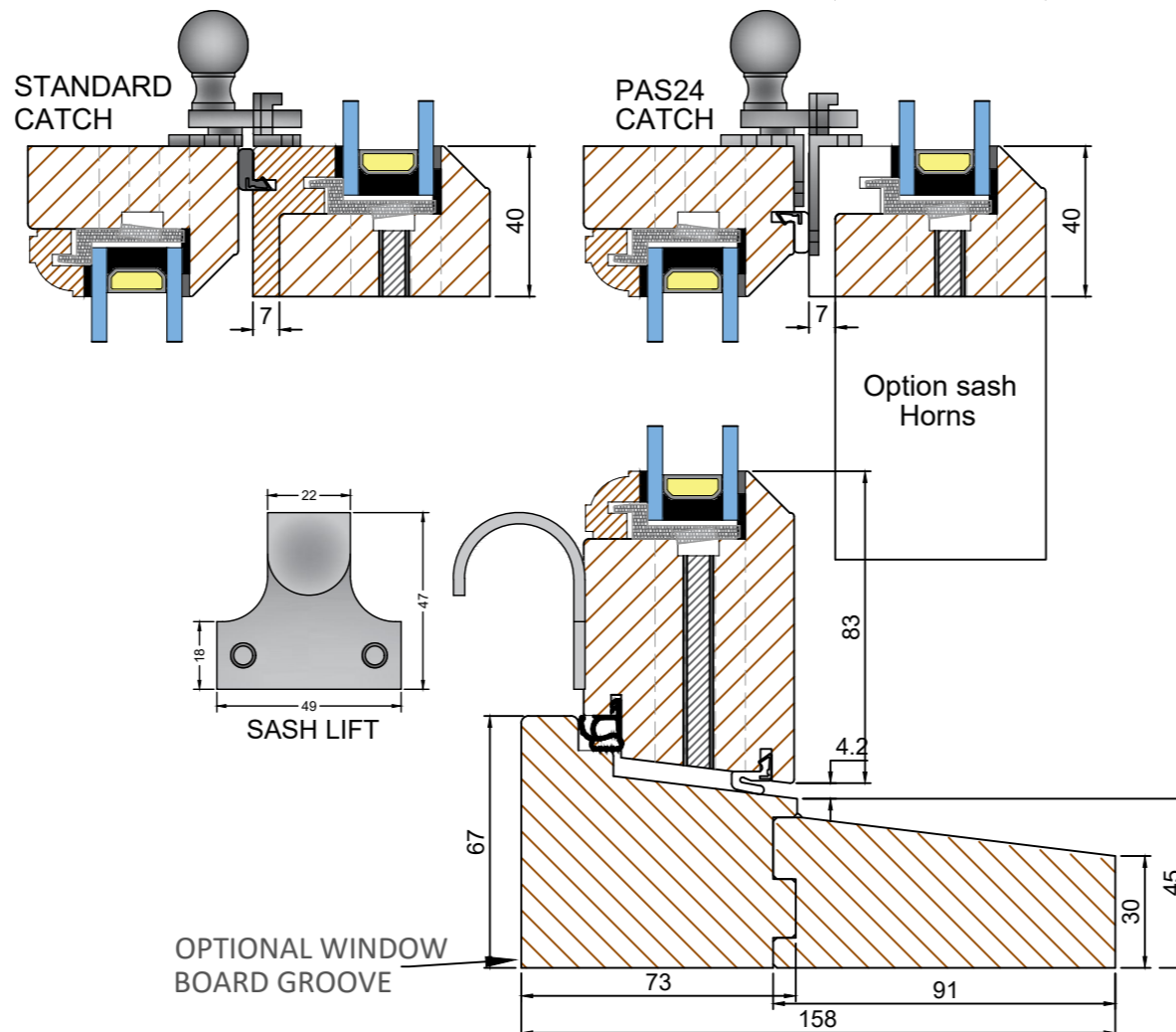
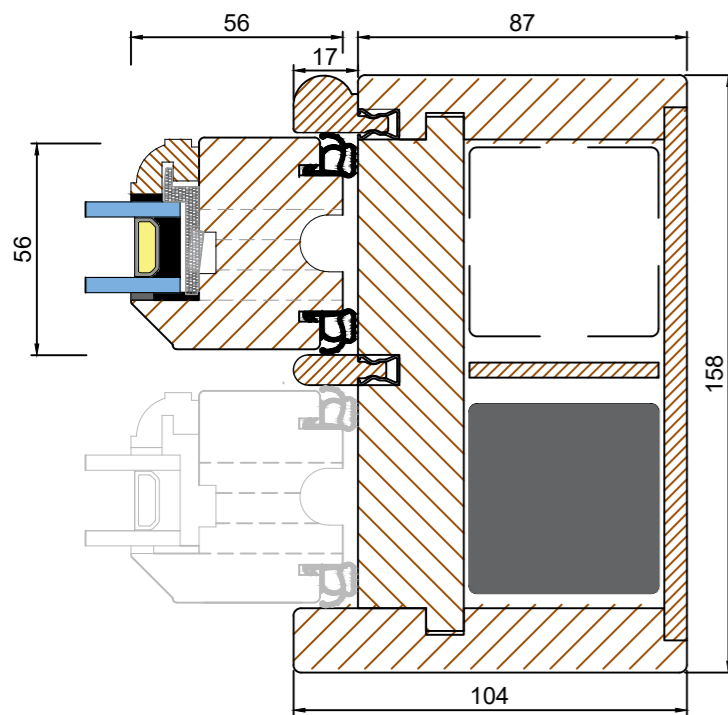

Elevation 2 - Inside View

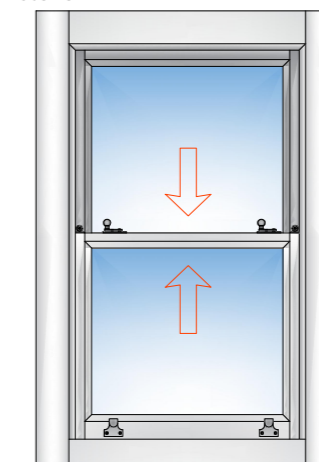

Purpose of Issue Legend:

- I = Information
- P = Planning
- B = Building Regulations
- Pr = Presentation
- T = Tender
- C = Construction
- LC = Last Contract

Notes:

rev	date	notes	purpose	drawn	checked
-----	------	-------	---------	-------	---------

TA+ studio

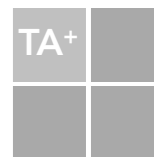

London:
+44(0)7425140604

www.ta-studio.co.uk

Ori Pliner

GF FLAT 48 Arkwright Road NW3 6BH
Typical single sash windows supplier details

1:100

Project	Series	Drawing	Revision
1521	40	03	