



Proposed Rooftop Extension
No 39 Elliott Square, NW3 3SU

Design & Access Statement
Prepared for Camden Council
June 2022

2217_39

BURD HAWARD ARCHITECTS
24 Wolsey Mews
London NW5 2DX

t: 020 7267 9815
e: studio@burdhaward.com

BHA

Contents

1.0 Introduction

2.0 The Existing Buildings & Local Context

2.1 Elliott Square

2.2 Local Context

3.0 Development Proposals

3.1 Description of Proposals & Design Approach

3.2 Form, Elevations and Materials

3.3 Internal Layout

3.4 Accessibility

3.5 Construction, Sustainability & Energy Use

3.6 Impact on Amenity of Neighbouring Properties

4.0 Planning Policy

5.0 Pre Application Consultation

5.1 Local Authority Consultation

5.2 Local Community Consultation

6.0 Conclusion



Front of No 39 Elliott Square, seen from the square



Rear of No 39 Elliott Square, seen from the drive of Elliot Square

1.0 Introduction

This Design and Access Statement accompanies the Planning Application for the construction of a roof extension to No 39 Elliott Square, NW3 3SU, which is part of a terrace, comprising Nos. 16-23. Planning Applications for similar roof extensions are being made simultaneously by Burd Haward Architects for the owners of No 19 - 23 with applications for similar extensions already submitted for No's.10-15.

This statement should be read in conjunction with the following drawings:

- 2217_39_P01 location & site plan
- 2217_39_P02 existing and proposed plans
- 2217_39_P03 existing elevations & section
- 2217_39_P04 proposed elevations & section
- 2217_39_P05 proposed views from Elliott Square & Adelaide Road

This report describes the existing building and local context, the proposals, the relevant planning policy and planning history, and the pre-application consultation with the local planning authority and local residents.



Site Plan of Elliott Square showing No 39



4 storey houses in Quickwood, with south facing terraces on the top floor



View of typical 2 storey houses in Quickwood

2.0 The Existing Building & Local Context

2.1 Chalcots Estate

Elliott Square lies within the Chalcots Estate. This is a collection of nine individual estates or 'sectors' that were all constructed by Eton College, and are located between Fellows Road to the north, Primrose Hill Road to the east, King Henry's Road to the south and Winchester Road to the west. The Chalcots Estate also includes the tower blocks Bray, Burnham, Dorney and Taplow, though these are owned by the local authority and are not part of the privately owned housing estates referred to in this report. The individual sectors are:

- Hawtrey (including Lyttelton Close) (70 houses)
- Elliott Square (55 houses)
- Quickswood (66 houses)
- Brocas (36 houses)
- Huson (41 houses)
- Briary (19 houses)
- Hornby Close (26 houses)
- Fellows Road (10 houses)

The estate was constructed in phases from the late 1960's through to the early 1980's, and comprises some 323 houses in total, both terraced and semi-detached, and of various heights. While the houses in the estate were originally built and leased by Eton College, the vast majority today are now privately owned. The common parts of the estate, the roads, gardens, pavements etc, are now owned by Chalcots Estate Ltd (CEL), who also manage the running of the estate in accordance with the 'Scheme of Management'. This company is owned and run collectively by all the residents, who elect its board from residents of every sector.

There are four basic house types within the estate as described below.

- 3 Storey Town Houses (223 in total)

These houses form the majority of the estate and are generally arranged in terraces of between 3 and 14. They are constructed of a dark brown brick with two vertical rows of windows separated by a white painted profiled metal cladding.

- 2 Storey Houses (65 in total)

These houses are the second most common, but are located in only the Quickswood and Hawtrey sectors and are detached or arranged in small terraces. They are constructed of a white painted brick with three vertical bays of windows separated horizontally by black timber boarding.

- 4 Storey Split Level Houses (19 in total)

These houses are only located in the Quickswood sector along Adelaide Road, and are grouped in three blocks of terraces. They are similar in appearance to the 3 storey town houses, but due to their split level arrangement, have a roof terrace to the rear of each house.

- 4 Storey Town Houses (16 in total)

Four of these houses are all located in the Hawtrey sector (facing Adelaide Road) and are similar in appearance to the 3 storey town houses, but have an additional 4th storey. Twelve have had their 4th floors added (Nos. 11-13 Lower Merton Rise & Nos. 24-32 Elliott Square).



Roof extensions to 24-34 Elliott Square, view from King Henry's Road



Roof extensions to 24-34 Elliott Square, view from Elliott Square

2.0 The Existing Building & Local Context (cont)

2.2 Elliott Square

No 39 is part of a terrace of eight similar 3 storey houses at the east of the square, who's front elevations face east towards the square and rear elevations face west towards Elsworthy Rise. All the houses within Elliott Square originally comprised the three storey 'Town Houses', and their heights vary across the square by up to 2.2m, due to the natural fall of the site from north to south. However, Nos. 24-32, located to the south of the estate, have recently had new floors added making them 4 storey (see photos opposite). These extensions were designed by Burd Haward Architects, following lengthy consultation with the residents and pre-application discussions with Camden Planning. The proposed extension to No 39 adopts a similar style to these extension, as they are felt to be an appropriate response to adding an additional storey and in order to maintain a consistent architectural style across the square.

2.3 Local Context

The north, east and west sides of Elliott Square are predominantly bounded by other sectors of the Chalcots Estate, and therefore by buildings of similar age and style (see descriptions above). Located on the corner of Adelaide Road and Elsworthy Rise, and adjacent to No 15, is a recent development of a terrace of five new 4 storey houses, which are designed in a more contemporary style.

The south side of Elliott Square faces onto large 5 storey Victorian semi-detached brick villas located on King Henry's Road. These houses form the northern edge of the Elsworthy Conservation Area. The Elsworthy Road Conservation Area Appraisal and Management Strategy defines the special interest of the area and describes the view west along King Henry's Road as being notable. However, it is considered that their physical distance to No 39 and lack of any view of the houses in the north of the square, means there would be no impact on the character of this Conservation Area.



Proposed front (west) elevation of extension to No 39 (highlighted)



Principles behind composition of proposed elevation

3.0 Development Proposals

3.1 Description of Proposals & Design Approach

The proposed development comprises the addition of a mansard type roof extension to the house, which is set back from the existing parapet to both the front and rear and provides two additional bedrooms and a bathroom. The roof extension is connected to the lower floors by extending the existing staircase. There is a central full height dormer window to the front and rear elevation, which aligns with the windows and step in the building façade below (see diagram opposite).

The approach taken by Burd Haward Architects has been to develop a design that:

- is appropriate and sympathetic to the architectural vocabulary of the estate's houses and is consistent with the other roof extensions that have been added to Nos. 24-32, in terms of massing, scale, form and materials;
- is drawn from traditional forms of roof extension, but applied in a contemporary manner that is in-keeping with the age and appearance of the houses.
- is designed to minimise the visual and amenity impact on neighbouring properties and the streetscape in general;
- is practical to build and easy to maintain;
- significantly improves the thermal performance of the existing houses, thereby reducing their energy use and CO2 emissions.

3.2 Form, Elevations and Materials

The roof extension has been carefully considered so that it forms a sympathetic addition to the existing building and streetscape. The adoption of a Mansard type form, with its set back from the parapet on both front and rear elevations and cladding in a traditional roof material, means the extension clearly reads as the buildings roof rather than as an additional storey, and also reduces its visual impact when viewed from street level. The height of the extension has been deliberately kept as low as possible to avoid overwhelming the building below, to ensure it is visually subservient to it and to reduce any perception of bulk.

Another traditional roofing element, the Dormer window, has been added to the basic mansard form to add visual interest to the roof line and to relate to the composition of the façades below. The existing houses are characterised by a central section of windows and cladding which is set back from the brick walls to either side. The dormers in the proposed roof extension relate directly to this, thereby continuing the vertical rhythm of the original building. The sliding glass doors to these dormers are divided into three to align with the windows below and have steel railings in front of them which match the existing railings to the 1st floor balcony.

The extension is clad in pre-weathered zinc standing seam panels, which is a high quality and traditional roofing material. Their durability and low maintenance characteristics make them ideally suited to this use and mean they will age well over time. Aluminium framed windows and doors will be painted to match the zinc to give a simple unified appearance to the extensions. Railings to be painted dark grey to match the cladding.

The proposed design is intended to match the existing roof extensions to Nos. 24-32 in terms of overall form and materials, in order to maintain a degree of continuity across the estate which reflect the uniform nature of the houses themselves.

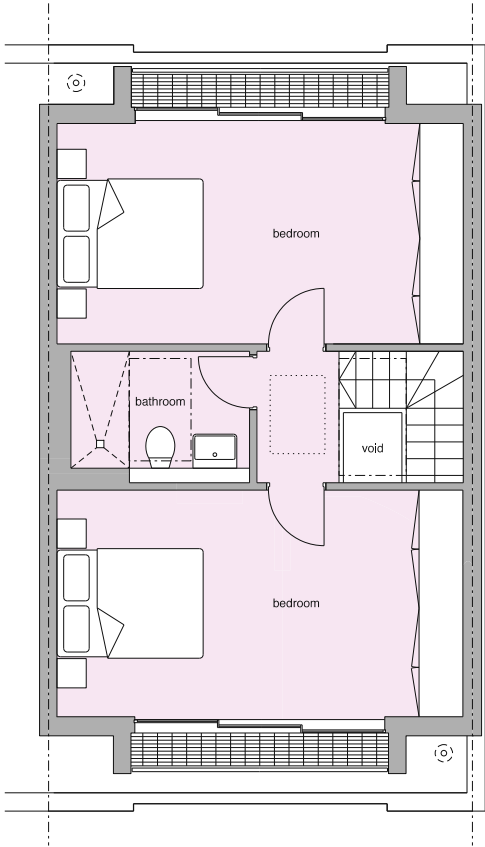

Proposed 3rd Floor Plan

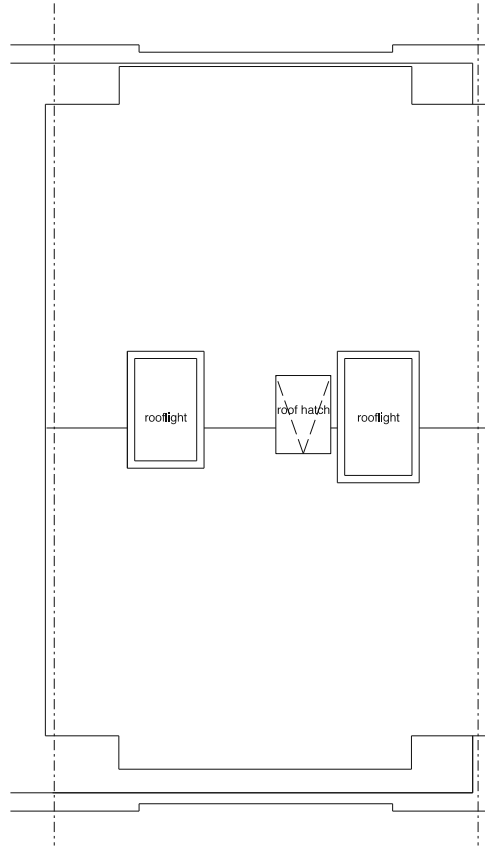

Proposed Roof Plan

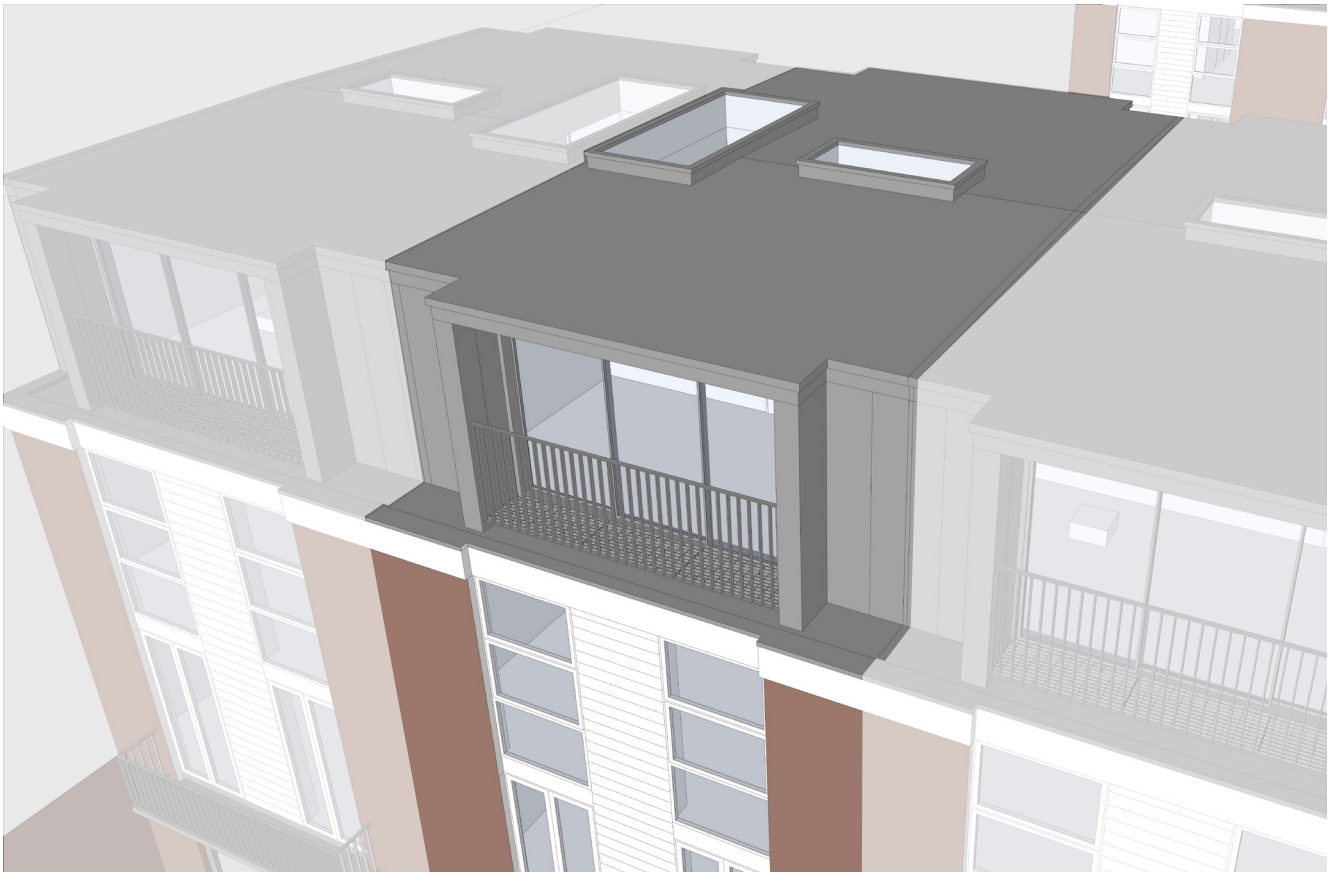

View of Proposed Roof Extension

3.0 Development Proposals (cont)

3.3 Internal Layout

The extension contains two bedrooms (15.2m² & 16.8m²) and a bathroom (5.1m²), with staircase leading from the second floor. The areas of the existing house and proposed extension are as follows:

Typical House Areas (GIA):

Ground floor	54.0m ²
First Floor	54.0m ²
Second Floor	54.0m ²
Total	162.0m ²

Proposed Roof Extension (GIA):

Third Floor	45.1m ²
-------------	--------------------

3.4 Accessibility

The proposed roof extension is accessed by means of a staircase that will be an extension of the existing staircase, and will be constructed to comply with Part K & M of the Building Regulations. As such, levels of accessibility to the roof extension will be as for the rest of the house.

3.5 Construction, Sustainability & Energy Use

The extension will employ a lightweight form of construction that imposes minimal additional load onto the existing building and uses the existing party walls to provide support for the new roof and ensure good fire and acoustic separation. In addition, the design allows for the majority of construction to be undertaken without requiring internal access, thereby minimising disruption to the occupants until the final stages of connection with the rest of the dwelling.

The existing house is constructed with uninsulated cavity walls and uninsulated flat roof, which means its thermal performance is poor and energy consumption is high in relation to its size. The proposed roof extension, which will have walls and roof insulated to current Part L Building Regulations, provide an ideal opportunity to improve the overall thermal performance of the house and initial calculations have shown that this will result in a saving of approximately 30%, in terms of energy required to heat the building.

3.6 Impact on Amenity of Neighbouring Properties

The potential impact on the amenity of neighbouring properties has been considered with respect to the proposed extension, and the conclusions summarised as follows:

- Windows to the front and rear elevations of the extension face front and rear windows of other houses in Elliott Square, with separation distances of between 18m and 20m. However, as all the existing windows have a similar relationship to neighbouring houses, no additional overlooking will occur as a result of these extensions.
- The setback of the extension from the existing parapet reduces its bulk and hence its visual impact when viewed from ground level within Elliott Square.
- Delva Patman Redler, were commissioned to produce a detailed Daylight and Sunlight study (attached to this application) to assess the effects of the proposed extension on the following adjacent properties:

- 14 & 16 Elsworth Rise, 4 - 39 Elliott Square, 20, 22, 24 & 28 Lower Merton Rise

In summary, their analysis found that all of the windows of these properties would continue to receive adequate daylight and sunlight levels in accordance with BRE guidelines. They therefore concluded that the proposed development was consistent with Camden's planning policy on daylight and sunlight.

4.0 Planning Policy

This proposal has been developed with reference to relevant Planning Policy and Guidance. The way in which the key policies have been addressed, is as follows:

- **Development Policy 2: Making full use of Camden's capacity for housing**

DP2 seeks to maximise the supply of additional homes in the borough through various means.

Para 2.9 states:

High development densities are one way of making the maximum use of a site, in the context of housing, this means more homes or rooms in a given area.

By adding floor space to the existing house, the proposed extension helps to achieve this goal by increasing the density of the estate as a whole. This additional space will provide much needed accommodation for the family already living there.

- **Development Policy 22: Promoting sustainable design and construction**

DP22 seeks to promote sustainable design in all new buildings. These proposals give the opportunity to significantly reduce the energy use of the original house.

- **Development Policy 24: Securing high quality design**

DP24 requires all development, including extensions, to meet a high standard of design which respects the setting, context, and the proportions and character of the existing building. As has been described above, this proposal has been carefully considered to respond to the particular character and form of the original house. The applicant is keen to ensure that the extensions will be detailed and constructed to the highest standards.

- **Development Policy 26: Managing the impact of development on occupiers and neighbours**
- **Camden Planning Guidance: 6 Amenity**

Policy DP26 ensures that any new development will not cause harm to the amenity of occupiers or neighbours. As noted, these proposals adhere to the guidance given in CPG 6 with respect to Section 6 - Daylight and sunlight and Section 7 – Overlooking, privacy and outlook.

- **Camden Planning Guidance: 1 Design**

CPG 1 contains specific guidance with relation to roof extensions within Section 5, as follows:

5.7 Additional storeys and roof alterations are likely to be acceptable where (they are) architecturally sympathetic to the age and character of the building and retain the overall integrity of the roof form;

5.8 A roof alteration or addition is likely to be unacceptable...where there is likely to be an adverse effect on the skyline, the appearance of the building or the surrounding street scene:

- Complete terraces or groups of buildings have a roof line that is largely unimpaired by alterations or extensions, even when a proposal involves adding to the whole terrace or group as a co-ordinated design;

Whilst there has been a general presumption against roof extensions being added to undeveloped terraces, the recent changes to Permitted Development Rights now give home owners the right to add an additional storey without requiring planning permission (see below), which is at odds with this policy.

4.0 Planning Policy (cont)

- **Camden Planning Guidance: 2 Housing**

The proposals have been designed in line with the residential development standards contained in CPG2.

- **Permitted Development Rights**

Current Permitted Development Rights (PDR's) would allow an additional floor to be added to the existing house without the need for a planning application. Unfortunately, this legislation requires any upward extension must copy the style and materials of the building below, which we consider a crude and inappropriate form of upward extension in this instance, which is also at odds with the precedent set by the additional floors added to Nos. 24-32. This application seeks to provide a sensible compromise between the objective of Camden's planning policy to ensure high quality of design with a householders right to add an additional storey. This approach has already been discussed with LBC (see 5.1 below).

5.0 Pre Application Consultation

Burd Haward Architects have been involved in discussions with local residents and the local authority in regard to this proposal. This consultation is summarised below:

5.1 Local Authority Consultation

- Chalcots Estate Ltd (CEL), the resident body that manages the whole of Chaclot Estate, are committed to protecting the quality and character of the estate. As such, CEL Chairman Howard Goldsobel and Catherine Burd architect and resident, met with Richard Limbrick and Jonathan McClue on 3rd June 2021. The purpose of the meeting was to think how Camden and CEL could work together to ensure design quality and consistency in applications coming forward in light of recent PD rights, given also that all applications require CEL approval, as well as planning approval.

Elliott Square already has nine houses which have roof extensions with a mansard roof and setback for which planning permission was granted after significant pre-app discussion and refinement of the design. It is felt this design sets a good and appropriate precedent for upwards extensions in the Elliott Square, rather than the 'cut and paste' version that would be permitted under PD rights.

The discussion thus focussed on what Camden's approach would be to individual applications that follow the approved mansard design, given that this falls outside the ambit of PDR for prior approval. RL confirmed that officers would work constructively with CEL and residents to agree and establish appropriate designs across the estate, and that they would be inclined to look favourably on applications that followed the Elliott Square mansard precedent, provided that they could be confident a similar level of quality and detail could be achieved.

5.2 Local Community Consultation

- The Elliott Square Residents Association (ESRA) has previously consulted residents on the idea of adding an additional floor as part of a general estate wide Design Guide that was put together to help control extensions and alterations in the square. This was formally adopted by residents in April 2013, when it was also agreed that the majority of residents were not opposed to the principle of roof extensions being added to houses on the estate.
- Meetings between many home owners within Elliott Square have taken place to discuss the potential of adding an additional storey. To date, twelve owners have agreed to a similar design and to make applications concurrently. Many of the other owners have expressed an interest in an additional floor, and may well follow in making an application once the outcome of current applications is known.
- CEL have previously approved the design of the additional floors added to Nos. 24-32, and have expressed a desire that further extensions should match these to maintain a consistent appearance.

6.0 Conclusion

The key conclusions of this statement are summarised below:

- The extension will provide much needed additional accommodation for the applicant's family. Providing such additional floor area is in line with the aims of Policy DP2, which seeks to increase Camden's housing supply and supports increasing density as a means of achieving this.
- The roof extension is sympathetic to the host buildings, in terms of form, detail and material and would not cause harm to its appearance. We believe adding a storey to the existing building actually improves its proportions and echoes more closely the majority of period terraces in the area.
- Due to its set-back at front and rear, the visual impact of the extension is reduced when viewed from ground level within Elliott Square. As a modern interpretation of a traditional type of roof extension, its appearance is in keeping with many of the period roof extensions in Camden.
- The applicant / owner is keen to ensure that the extension will be detailed and constructed to the highest standard and so will make a positive contribution to the character of Elliott Square.
- While single roof extensions have historically been resisted by LBC, we believe these proposals would be a significant improvement on a crude 'cut & paste' additional floor if implemented in-line with current PDR's. In addition, this application makes up one of four concurrent applications for similar extensions, with others in the terrace likely to follow, which would achieving uniformity across the whole terrace.
- LBC have confirmed they would look favourably on future roof extensions that maintained the style and quality of those already in the square.