

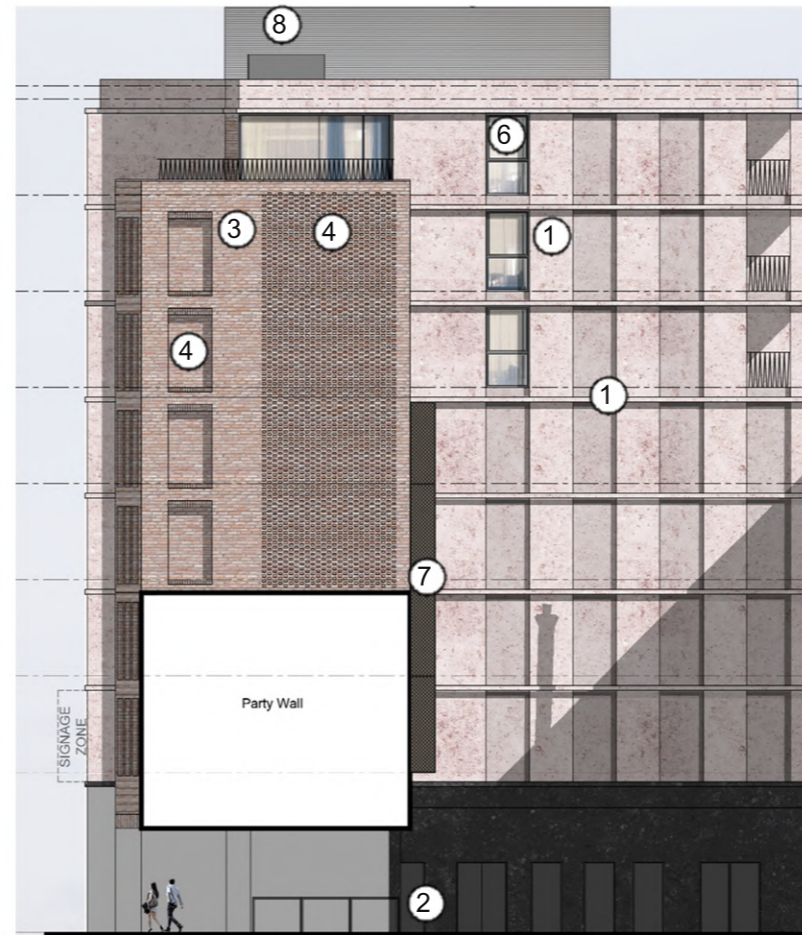

East Elevation

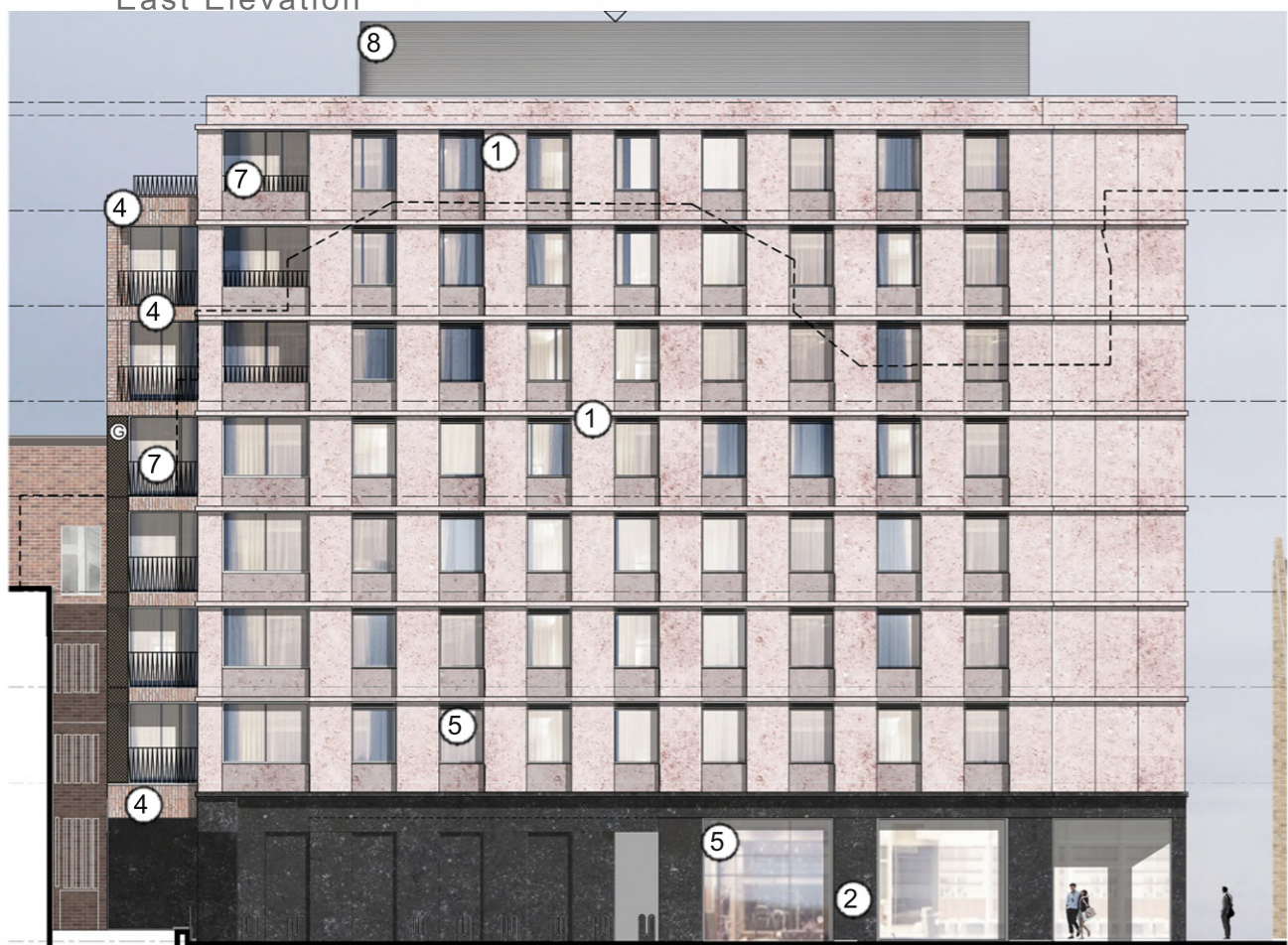

North Elevation



West Elevation



South Elevation

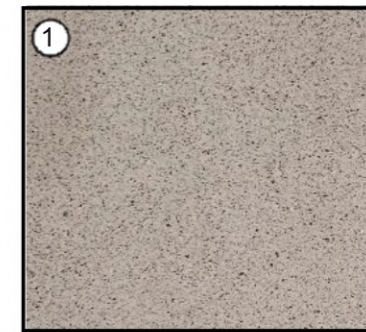

1
CONCRETE CLADDING:
BBF 38323 WL1

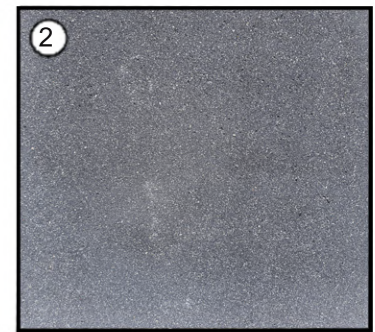

2
CONCRETE CLADDING:
BBF 3832 H-MGI

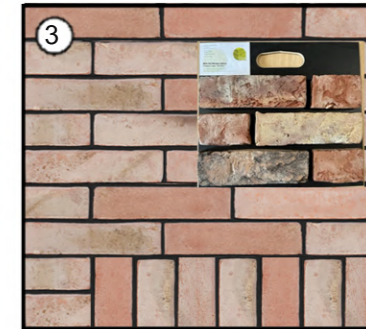

3
RESIDENTIAL BRICK &
BRICK SLIPS (inc SOLDIER
COURSE HEADER:
BEA Old Windsor
Ref:2910021

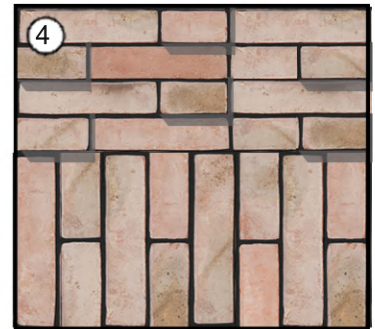

4
RESIDENTIAL FEATURE
PROJECTING BRICK & VER-
TICALLY LAID BRICK SLIPS:
BEA Old Windsor
Ref:2910021

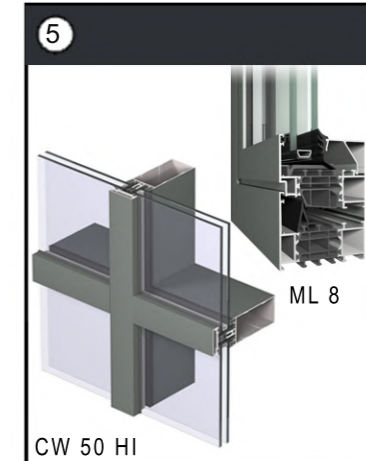

5
HOTEL DOUBLE GLAZED
ALUMINIUM WINDOWS &
DOORS: Reynaers CW 50 HI
(ground floor) & Reynaers
ML 8 (all upper floors).
RAL 7021 matt

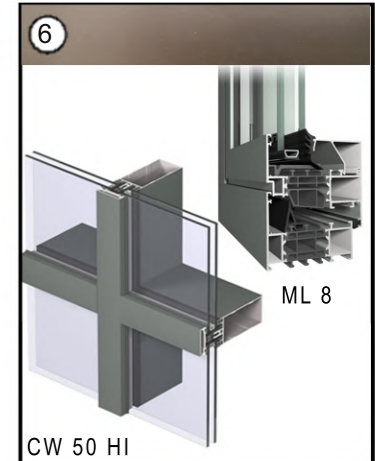

6
RESIDENTIAL DOUBLE
GLAZED ALUMINIUM
WINDOWS & DOORS:
Reynaers CW 50 HI (ground
floor) & Reynaers ML 8 (all
upper floors).

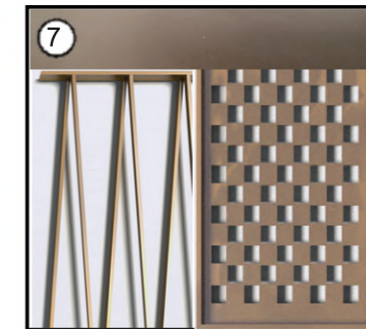

7
PERFORATED METAL
PANELS & BALUSTRADES:
RAL:8070, Sample Awaited

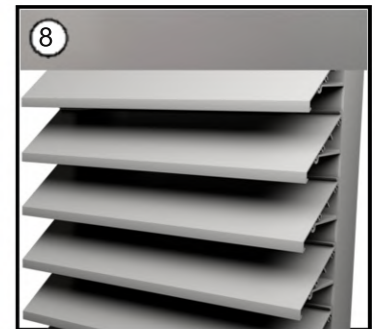

8
PLANT / SUB-STATION
ENCLOSURE:
Sunray louvre system
RAL:7040