

NOTES

- This drawing is for engineering services only and is to be read in conjunction with all relevant architectural, structural, MTT drawings and the Contract specification.
- THIS IS NOT AN INSTALLATION DRAWING.
- All services routes and equipment locations are indicative, actual location and configuration to be determined by contractor following completion of contractor design and coordination.
- This drawing will only be issued in PDF format.
- All switchboards, Distribution boards etc shall have 25% spare capacity.
- Each outgoing way from the Landlords LV switchboard shall have BMS facility for monitoring:
 - Open/Closed
 - Tripped
 - kWh pulsed signal from meter where fitted.
- Spare tap off points shall be available for future tenant/retail use as required.

SWITCHGEAR LEGEND

- Life Safety / Essential services
- Landlord's Life Safety Services
- Landlord Power
- Tenant 1
- Tenant 2

CABLE LEGEND

- BNO LV XLPE/SWA/LSF cables
 - Landlord LV XLPE/SWA/LSF distribution cables
 - Life safety/Primary Supply (FTP 120)
 - Life safety/Secondary Supply (FTP 120)
- DNO LV XLPE/AWA/LSF cables (Being installed as part of enabling works prior to main contract works)
- All meters where indicated shall be fitted with pulsed output and linked into the BMS system for full energy monitoring at the head end.



BMS

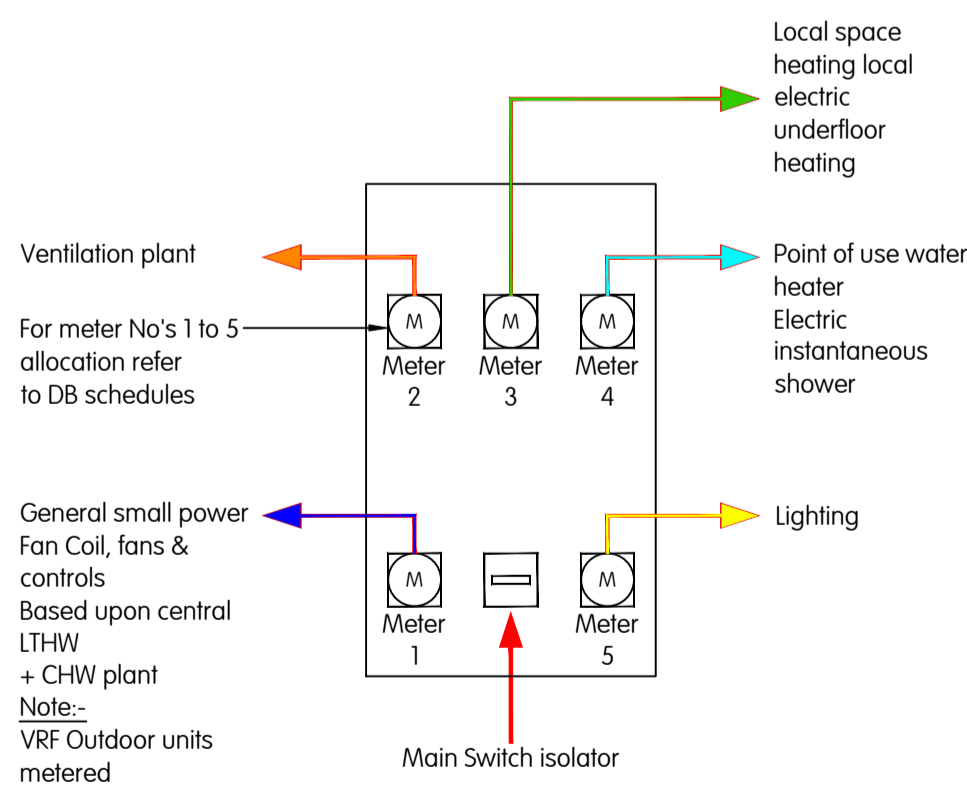

Typical Metering Allocation

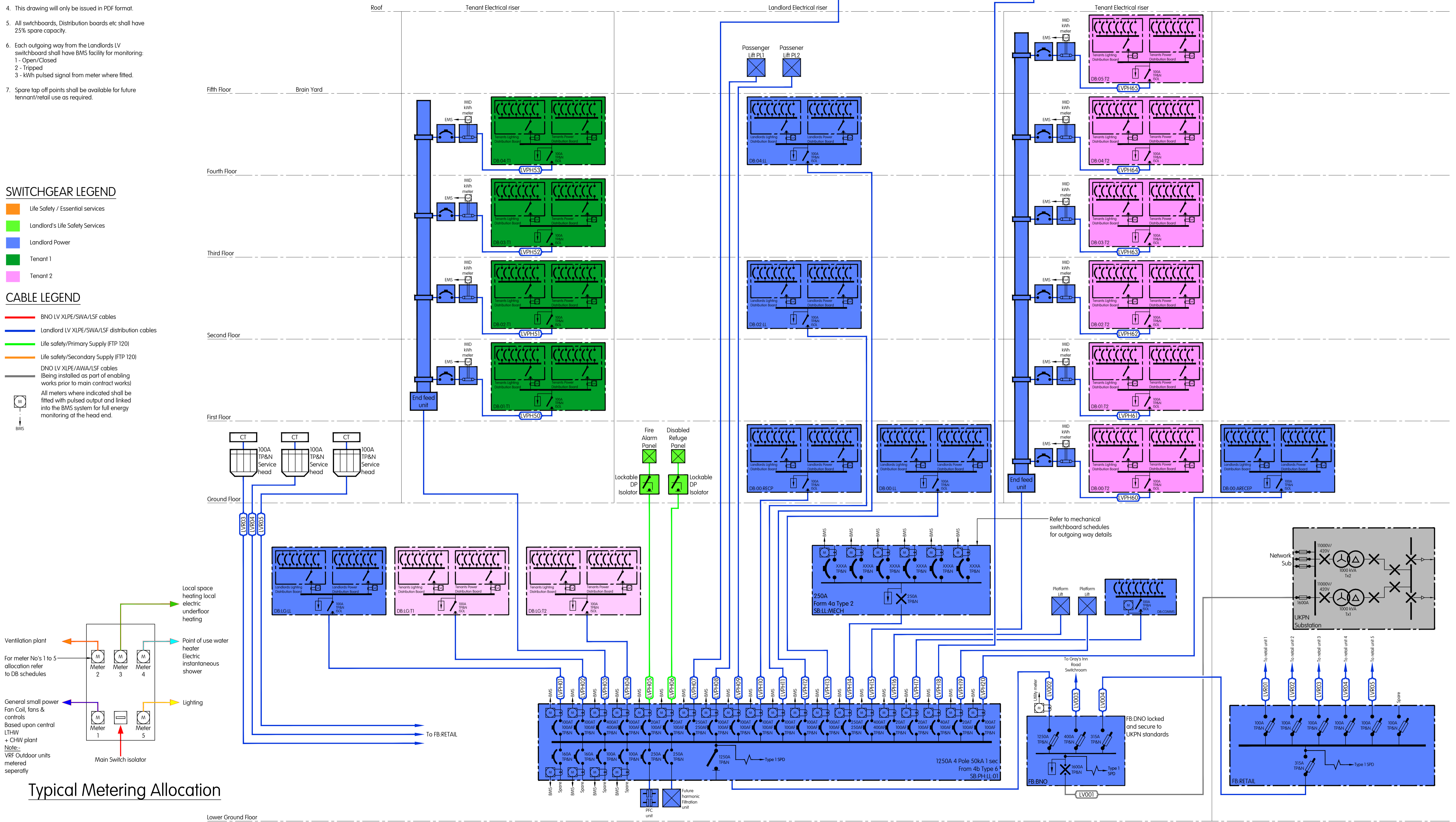

Copyright by mTT. No copies of this drawing, however produced and/or transmitted, may be made or undertaken without the express permission of mTT. This drawing should not be scaled. All dimensions to be checked on site and any discrepancies to be notified to mTT.

Based on architectural drawing/s:

TI	21.10.2021	Stage 4 Issue	ZP	LC
Rev	Date	Description	Drawn	Checked

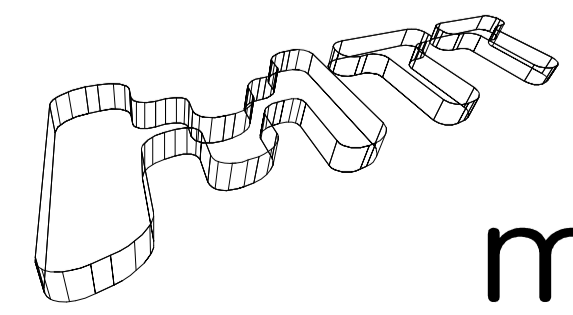

MTT/DRAWING

A 9 KINGSWAY
LONDON
WC2B 6XF
T +44 (0)20 7836 1133
F +44 (0)20 7836 1153
E info@mtt-limited.com
W www.mtt-limited.com

PM L Curtis
Cod V Popovic
Date February 2021
Scale NTS@A1
Status STAGE 4

Panther House
Electrical Services
Panther House
LV Schematic
Drg No: 7127-MTT-PH-ZZ-DR-E-1100
Revision T1

