

SAFETY, HEALTH AND ENVIRONMENT INFORMATION

THE DRAWING IS THE PROPERTY OF HS2 LIMITED AND IS NOT TO BE REPRODUCED OR TRANSMITTED IN ANY FORM OR BY ANY MEANS, ELECTRONIC OR MECHANICAL, WITHOUT THE WRITTEN PERMISSION OF HS2 LIMITED.

CONSTRUCTION

WORKERS MUST BE AWARE OF THE LOCATION OF ALL SERVICES AND EQUIPMENT. ALL SERVICES AND EQUIPMENT MUST BE PROTECTED FROM DAMAGE AND REMOVED FROM THE WORK AREA BEFORE ANY WORK COMMENCES.

OPERATIONS

THE DRAWING IS THE PROPERTY OF HS2 LIMITED AND IS NOT TO BE REPRODUCED OR TRANSMITTED IN ANY FORM OR BY ANY MEANS, ELECTRONIC OR MECHANICAL, WITHOUT THE WRITTEN PERMISSION OF HS2 LIMITED.

MAINTENANCE

ALL SERVICES AND EQUIPMENT MUST BE PROTECTED FROM DAMAGE AND REMOVED FROM THE WORK AREA BEFORE ANY WORK COMMENCES.

REVISIONS

ALL SERVICES AND EQUIPMENT MUST BE PROTECTED FROM DAMAGE AND REMOVED FROM THE WORK AREA BEFORE ANY WORK COMMENCES.

THE DRAWING IS THE PROPERTY OF HS2 LIMITED AND IS NOT TO BE REPRODUCED OR TRANSMITTED IN ANY FORM OR BY ANY MEANS, ELECTRONIC OR MECHANICAL, WITHOUT THE WRITTEN PERMISSION OF HS2 LIMITED.

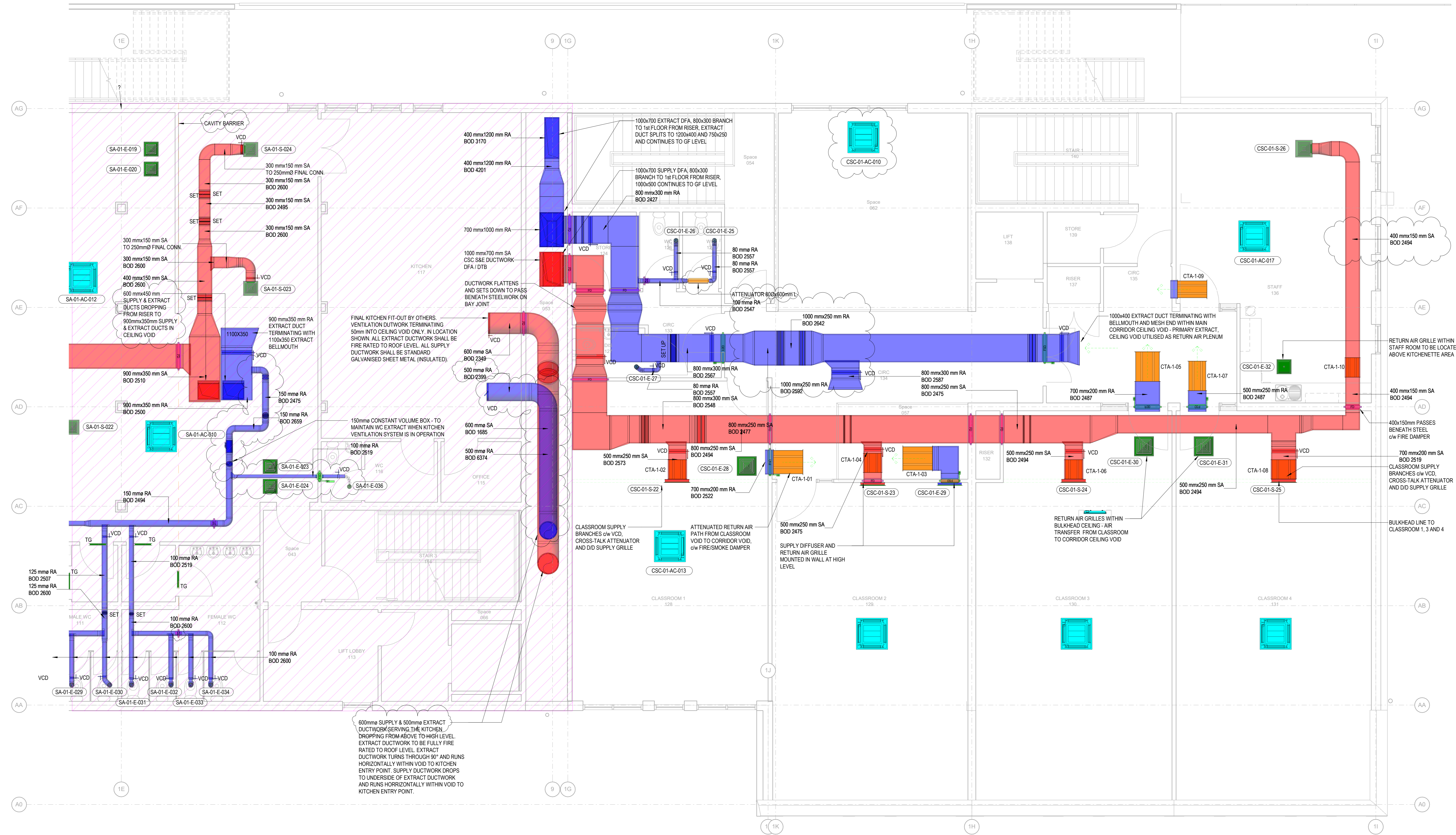

NOTES

- ALL DUCTWORK SYSTEMS INSTALLED IN ACCORDANCE WITH DW144 SPECIFICATION FOR CLASS A SYSTEMS.
- ALL DUCTWORK MANUFACTURED FROM HOT DIP GALVANISED STEEL TO BS EN10119:1991, UNLESS NOTED OTHERWISE ON THE DRAWINGS.
- RECTANGULAR DUCTWORK CROSS JOINTS SHOULD BE SEALED IN ACCORDANCE WITH DW144 FIGS 10, 13&14, FASTENINGS AND MAXIMUM SPACINGS IN ACCORDANCE WITH SECTION 10.7.
- CIRCULAR DUCTWORK SPIRAL WOUND AND STRAIGHT SEAMED JOINTS SEALED IN ACCORDANCE WITH DW144 FIGS 32-45, FASTENINGS AND MAXIMUM SPACINGS IN ACCORDANCE WITH SECTION 13.3.
- ACCESS PANELS PROVIDED ADJACENT TO ALL FIRE DAMPERS, UNLESS REMOTE ACCESS TYPE COMBINED FIRE DAMPER VCD'S ARE TO BE USED.
- ALL ACCESS/INSPECTION HATCHES ARE PROPRIETARY MANUFACTURED WITH QUICK RELEASE CATCHES AND SELF SEALING GASKETS.
- ALL ACCESS/INSPECTION PANELS REMAIN ACCESSIBLE, THE INSULATION CONTRACTOR HAS SUITABLY DRESSED THE EDGES OF THE INSULATION TO THE EDGE OF THE ACCESS OPENING.
- THE USE OF FLEXIBLE DUCTWORK IS LIMITED TO 1000mm IN LENGTH TO MAKE FINAL CONNECTIONS ONLY - NOTE ADDITIONAL LENGTH MAY BE REQUIRED TO ALLOW TRANSITION TO PLENUM CONNECTIONS IN SOME AREAS.
- DUCTWORK MANUFACTURED WITH GRADUAL TRANSFORMATIONS AND CHANGES OF SHAPE/DIRECTION.
- FLEXIBLE CONNECTIONS INCORPORATED WITHIN THE DUCTWORK SYSTEM TO ISOLATE THE DUCTWORK EQUIPMENT.
- GRILLES AND DIFFUSERS PROVIDED WITH SUITABLE PURPOSE MADE PLENUM BOXES (SIDE OR TOP ENTRY SPIGOT AS NECESSARY) WHERE INDICATED.
- ALL GRILLES AND DIFFUSERS PROVIDED WITH BALANCING DAMPERS WITHIN THE DUCTWORK SERVING THE GRILLE OR DIFFUSER - SINGLE LEAF TYPE ON FINAL BRANCHES.
- ALL GRILLES AND DIFFUSERS HAVE A FINISH COLOUR TO SUIT THE ARCHITECT'S REQUIREMENTS.
- ALL AIR DISTRIBUTION DUCTS PASSING THROUGH ELEMENTS OF STRUCTURE FORMING FIRE COMPARTMENTS SHALL INCORPORATE A FIRE DAMPER, OR COMBINED FIRE AND SMOKE DAMPERS TO PREVENT SMOKE MIGRATION TO EMERGENCY ESCAPE ROUTES. DAMPER RATINGS SHALL BE AS PER THE FIRE STRATEGY DRAWING, 30min, 60min OR 90min.
- FIRE DAMPERS, OR COMBINED FIRE AND SMOKE DAMPERS SHALL BE PROVIDED IN THE LOCATIONS AS INDICATED ON THE DRAWINGS. THE SMOKE DAMPER PANEL SHALL BE LOCATED ADJACENT TO THE FIRE ALARM PANEL SERVING THE CSC AND SA AREAS.
- THE FIRE DAMPER BLADE IS OF STAINLESS STEEL CONSTRUCTION AND SHALL BE HELD IN THE OPEN POSITION BY MEANS OF A THERMAL RELEASE MECHANISM RATED AT 72°C ± 1°C.
- ALL BRANCHES FROM THE MAIN DISTRIBUTION DUCTS ARE BY A SMOKE BRANCH FITTINGS.
- ALL FRESH AIR INTAKE DUCTWORK IS INSULATED, VAPOUR SEALED AND WEATHERPROOFED WHERE NECESSARY (ATMOSPHERE SIDE ONLY AND/OR WHERE AIR SUPPLIED IS USED TO PROVIDE SPACE HEATING/COOLING). THE INSULATION HAS AN ENVIRONMENTAL THICKNESS BETWEEN 20MM AND 50MM (TO SUIT THE IN DUCT AND AMBIENT AIR TEMPERATURES) WITH A MAXIMUM THERMAL CONDUCTIVITY OF 0.035 W/mK.
- ALL ROOM SIDE DUCTWORK SYSTEMS, AND EXHAUST DUCTWORK SYSTEMS, ARE TO BE FULLY INSULATED; DISTRIBUTION OF CONDITIONED AIR WITH HEAT RECOVERY SYSTEMS.
- UPON COMPLETION OF THE WHOLE VENTILATION INSTALLATION THE SYSTEM IS BALANCED AND COMMISSIONED IN ACCORDANCE WITH CIBSE COMMISSIONING CODE A.

LEGEND

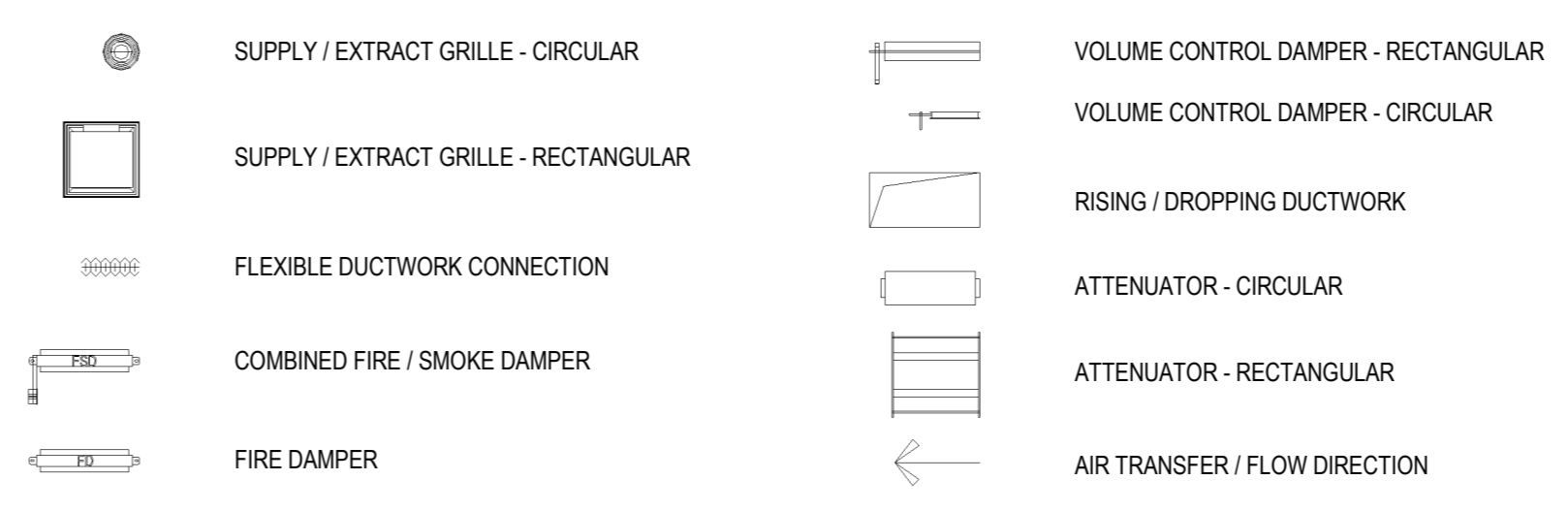

Rev	Description	Drawn	Checked	Approved	Con App	Scale	Notes
C02	STAGE 4 ISSUE	JB	ET	MMc			HS2 accepts no responsibility for any circumstances which arise from the reproduction of this document after alteration, amendment or abbreviation if it is issued in part or issued incompletely in any way.
C01	PRELIMINARY ISSUE FOR COMMENT	JB	ET	MMc			© Crown Copyright and database right 2020. All rights reserved. Ordnance Survey Licence number 100049150. This material was last updated on 2020 and may not be copied, distributed, sold or published without the formal permission of Land Registry. Only an official copy of a title plan or register obtained from the Land Registry may be used for legal or other official purposes.

Legends/Notes:

Scale with caution as distortion can occur.

HS2

OFFICIAL

Registered in England
Registration No. 06791686
Registered office:
2 Snow Hill, Queensway,
Birmingham, B4 6GA

Stage	Project/Contract	Owner/Originator	Sub-Originator
4	Euston Station	PREMIER MODULAR	
Drawing Title	Work Package Description	Discipline/Function	System Description
LEVEL 01	1200503	MECHANICAL	
Drawing No.	Scale	Size	Subsidiary
2 of 2	1:50	A0	S4
Drawn by	Checked by	Approved by	Date
JB	ET	MMc	24.01.22
Scale	Size	Subsidiary	Rev.
1:50	A0	S4	C02
Drawing No.	1CP01-MDS_PML-EME-DGA-S508_SL23_F1-000008		