

ROOF GLAZING  
FRAGILITY - NON-FRAGILE CLASS B TO ACR(M)001;2019

STALK CUT BACK SIZE - 100mm  
GLAZING MATERIAL - POLYCARBONATE  
GLAZING THICKNESS - 16mm  
GLAZING COLOUR - TBC  
GLAZING BAR COLOUR - TBC

STRUCTURE  
STRUCTURE MATERIAL - ALUMINIUM  
STRUCTURE COLOUR - TBC  
SECTIONS - AS INDICATED ON DRAWING  
FINISH - POLYESTER POWDER COATED

FLASHINGS  
FLASHING MATERIAL - PRESSED ALUMINIUM  
FLASHING COLOUR - TBC  
BUTYL SEAL - WHITE/LEAD LOOK

RAIN WATER GOODS  
GUTTER MATERIAL - TWINFIX ALUMINIUM  
GUTTER COLOUR - TBC  
DOWNPIPE MATERIAL - TWINFIX ALUMINIUM  
DOWNPIPE COLOUR - TBC  
DRAINING TO - SHOE TO SURFACE DRAIN AND EXISTING DRAIN  
NOTE: TWINFIX GUTTER AND DOWNPIPES ARE DESIGNED FOR THE WATER FLOW OF THE TWINFIX CANOPY ROOF/PANELS ONLY. IF ANY OTHER NO-TWINFIX ROOFS OR DOWNPIPES ARE DRAINING ONTO THE TWINFIX SYSTEM THEN THIS WILL NOT BE COVERED BY THE TWINFIX GUARANTEES UNLESS AGREED PRIOR TO DRAWING APPROVAL

GROUNDWORKS  
CONCRETE TYPE - C30 (MINIMUM)  
FOUNDATION POT SIZE - REFER TO STRUCTURAL CALCULATIONS  
BACK FILL MATERIAL - ASPHALT BY OTHERS  
MINIMUM GROUND BEARING PRESSURE - 95kN/M<sup>2</sup> (TO BE CONFIRMED BY OTHERS)

FIXINGS  
ALL FIXINGS SCREWS AND BOLTS TO BE STAINLESS STEEL WHEN USED FOR ALUMINIUM STRUCTURES  
ALL RESIN ANCHORS TO BE POSITIONED TO AVOID JOINTS IN MASONRY.  
RESIN ANCHORS TO BE ALLOWED TO CURE IN ACCORDANCE WITH MANUFACTURERS RECOMMENDATIONS PRIOR TO INSTALLATION

SETTING OUT DIMENSIONS TAKEN FROM TWINFIX SITE SURVEY

SETTING OUT DIMENSIONS  
CANOPY SETTING OUT DIMENSIONS ARE THE RESPONSIBILITY OF TWINFIX

TOLERANCES  
UNLESS STATED OTHERWISE  
GENERAL BUILDING DIMENSIONS +/- 10mm  
SETTING OUT DIMENSIONS +/- 25mm  
FABRICATION DIMENSIONS +/- 2mm  
PRODUCTION DIMENSIONS +/- 2mm  
ALL TOLERANCES ARE NON-ACCUMULATIVE

GENERAL  
ALL DIMENSIONS IN MILLIMETERS UNLESS STATED OTHERWISE.  
FOR WELDING STANDARDS REFER TO TWINFIX STANDARD FABRICATION FOLDER SHEET REFERENCES CMP-WS01 TO 06 INCLUSIVE (AVAILABLE ON REQUEST).  
DO NOT SCALE FROM THIS DRAWING.

NOTES FOR THE CONTRACTOR:  
• CONTRACTOR TO CONFIRM LOCATION OF RWP AND HOW THEY ARE TO BE DISPERSED  
• STRUCTURAL CALCULATIONS REQUIRED PRIOR TO MANUFACTURE.

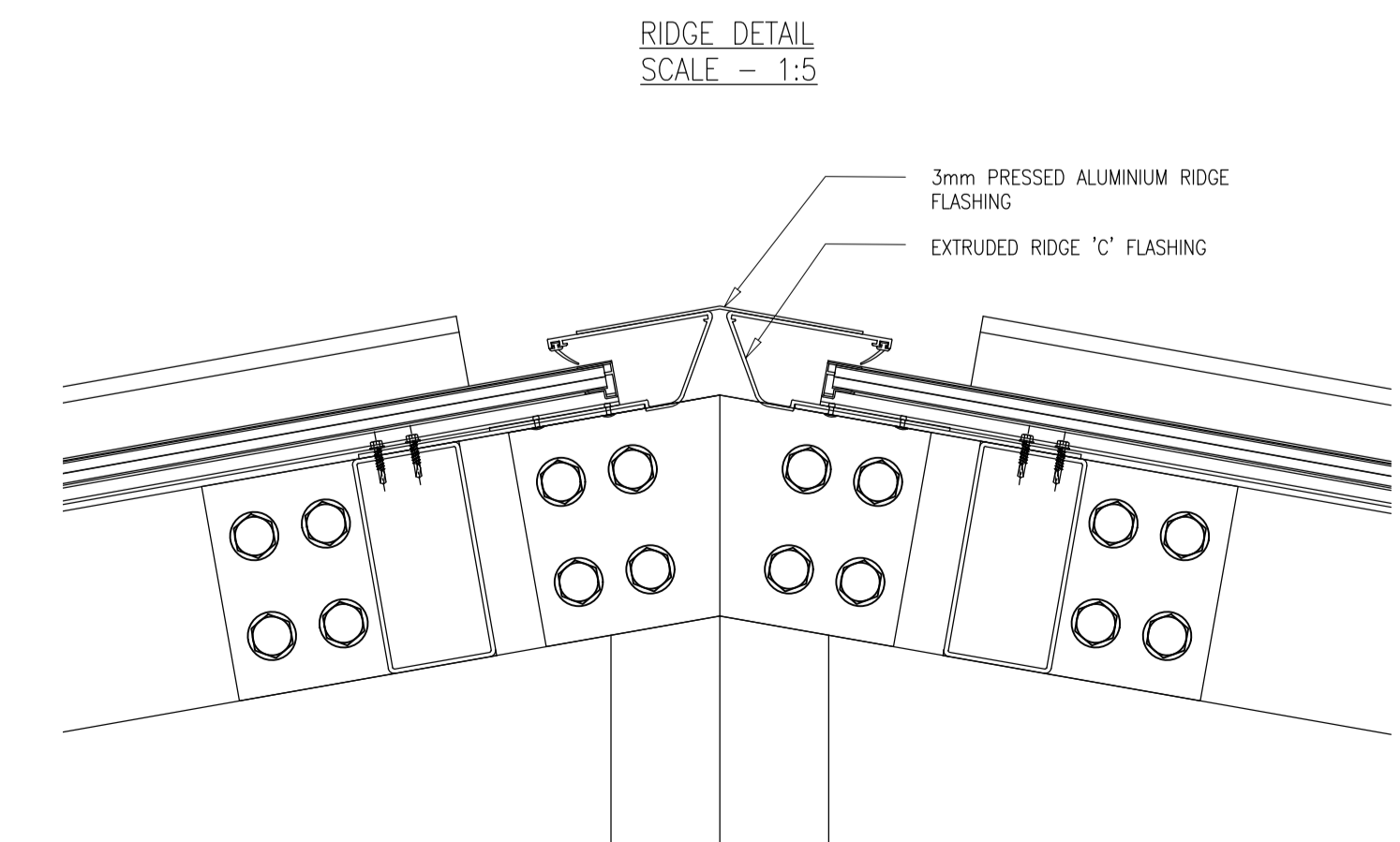
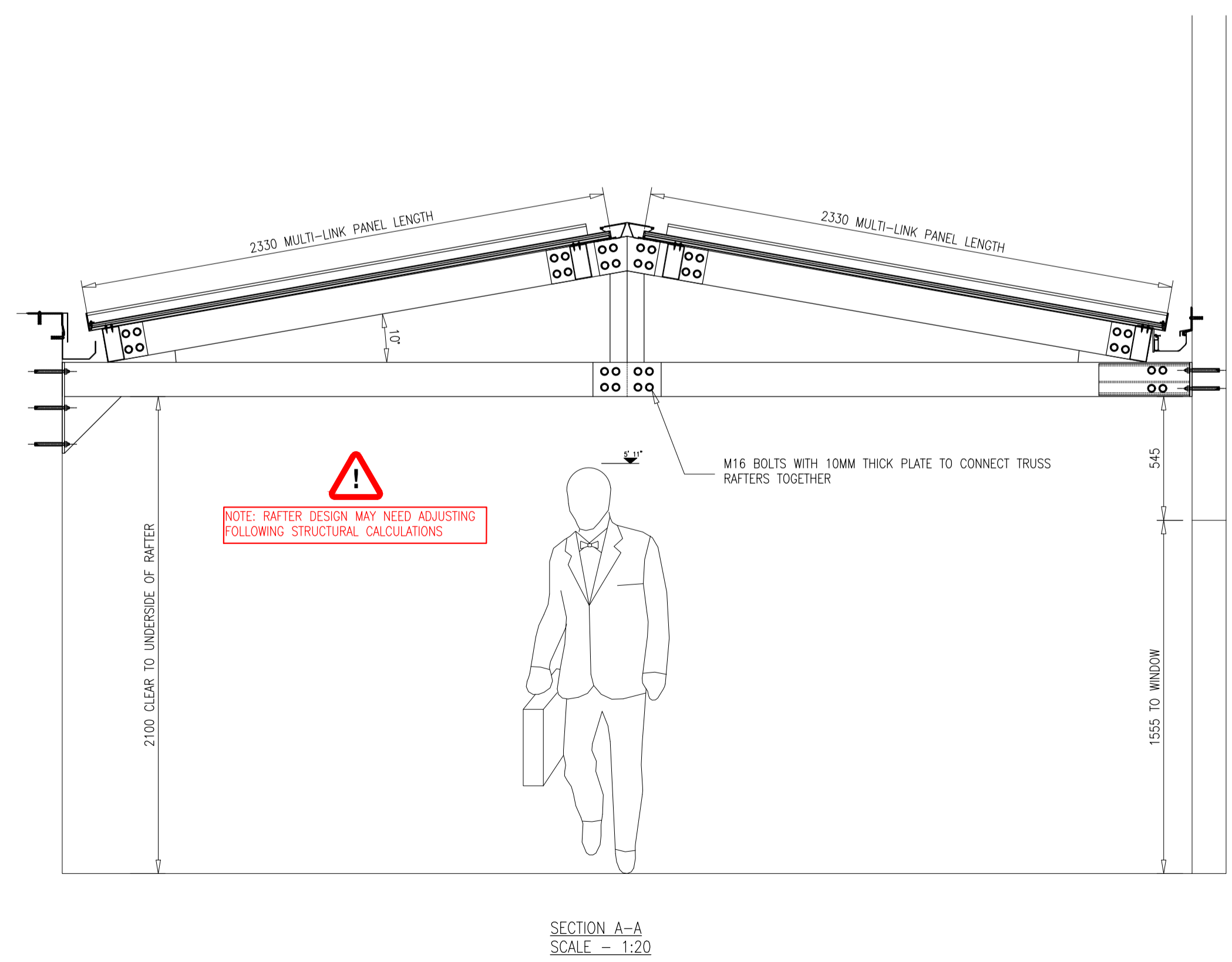
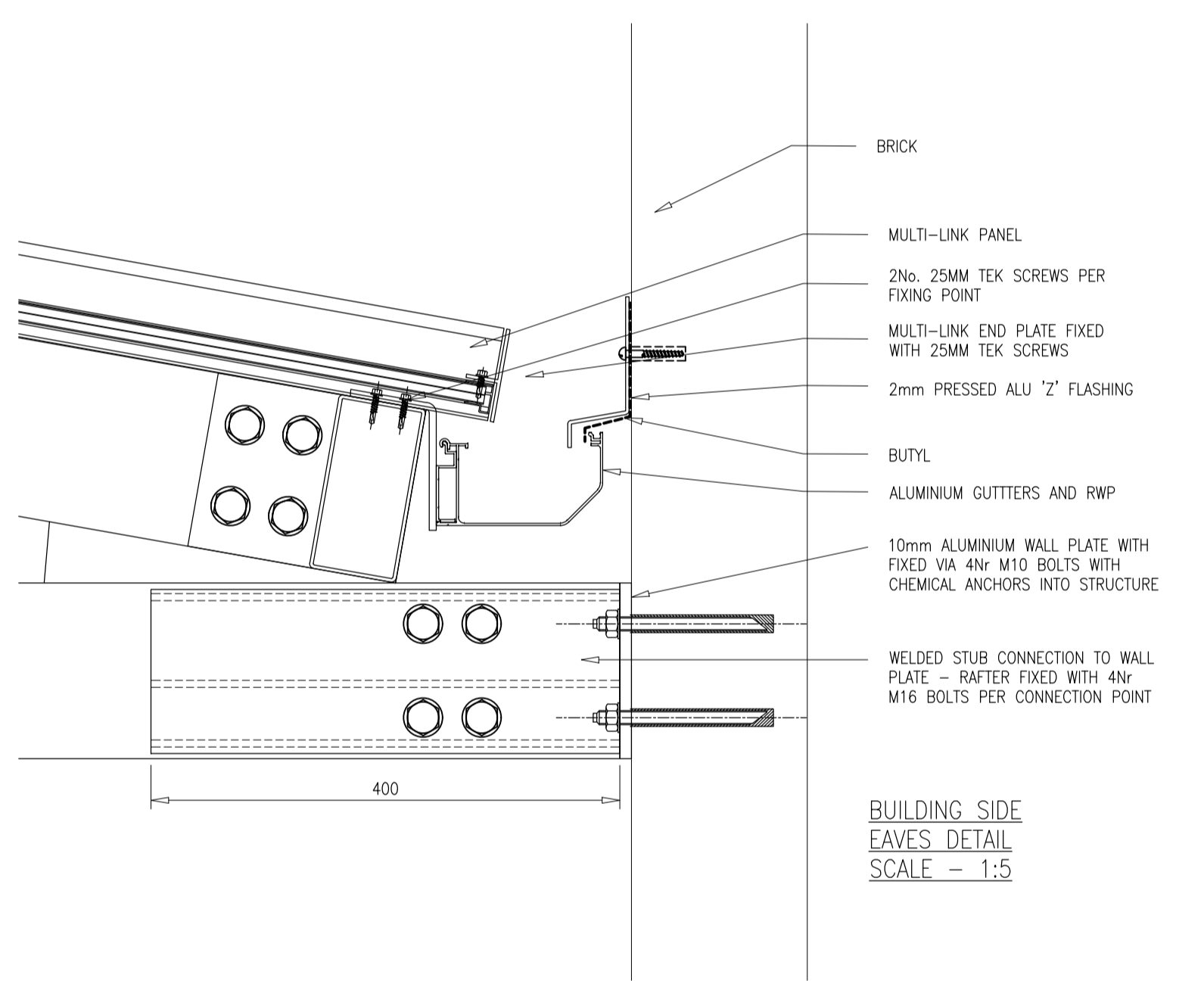
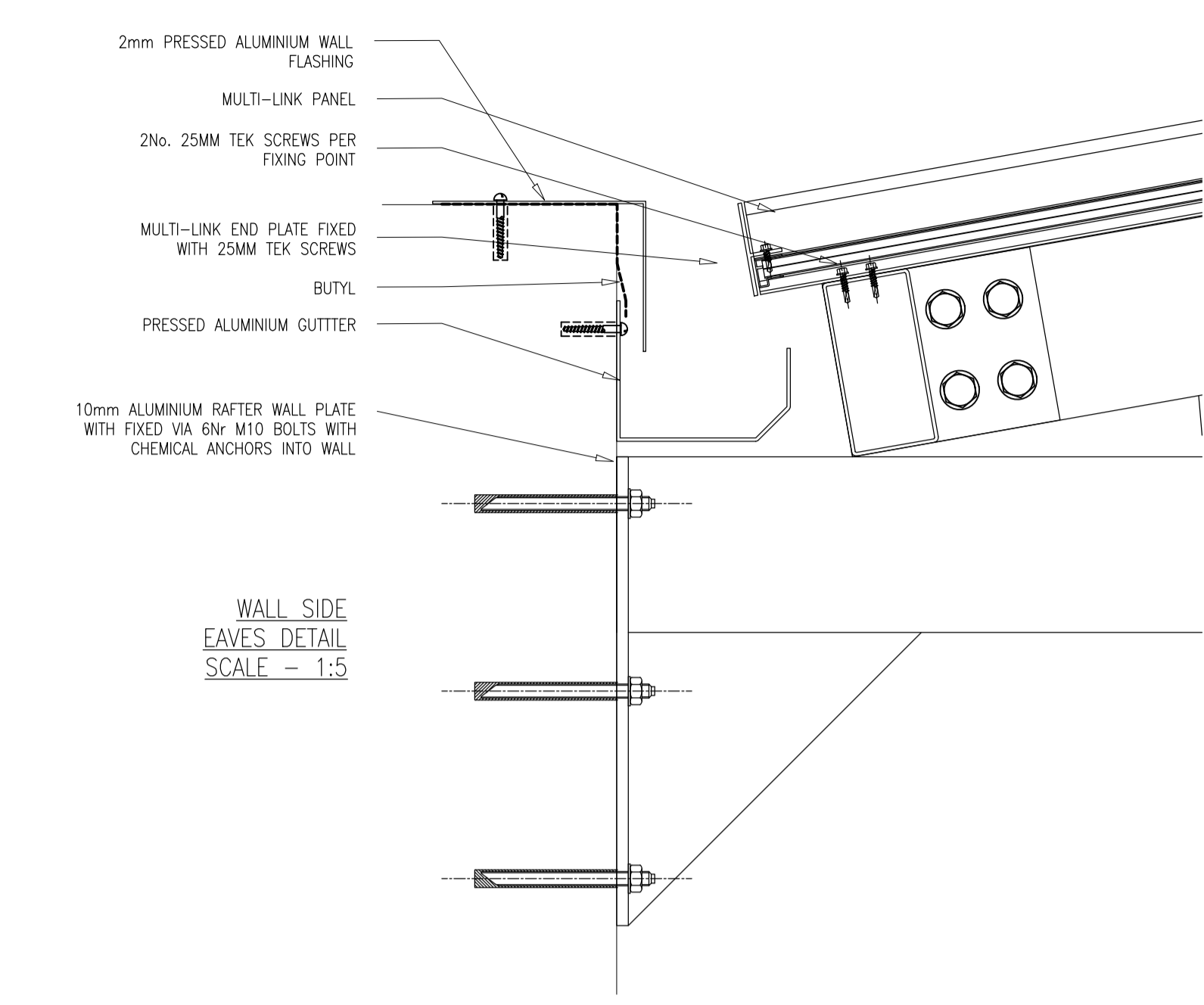
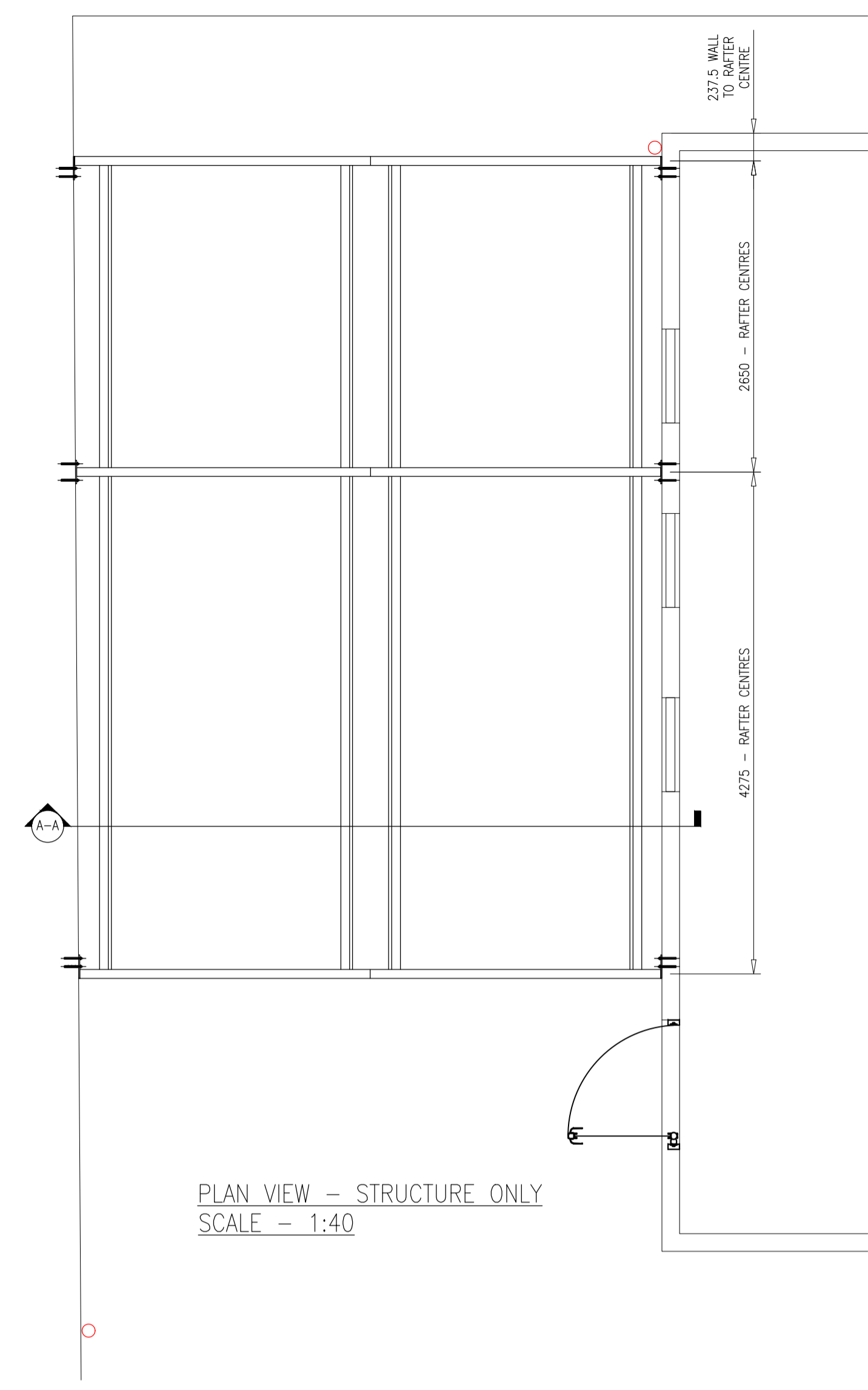
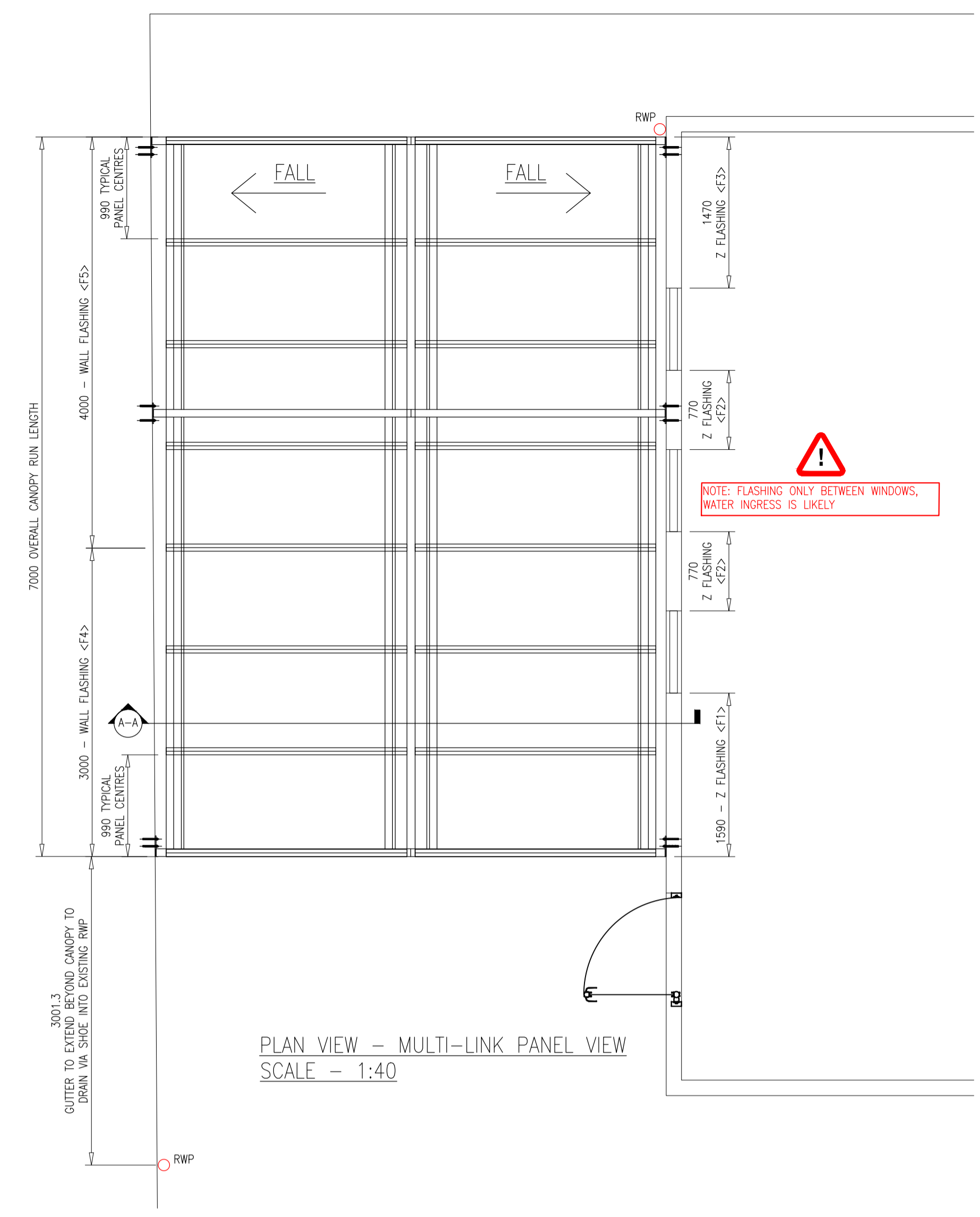

REV	NO	DESCRIPTION OF REVISION	DATE	BY
-	-	-	-	-

ISSUED FOR APPROVAL

**TWINFIX**  
TWINFIX LIMITED  
201 CAVENDISH PLACE,  
BRICKWOOD PARK,  
BRICKWOOD  
WARRINGTON  
WA5 0BU  
TEL: 01925 811 311  
M18 www.twinfix.co.uk  
EMAIL: sales@twinfix.co.uk

This drawing is a confidential communication and is the property of Twinfix Limited and is returnable on request. It must not be copied, loaned or communicated without the written consent of Twinfix Limited. ©2019

CUSTOMER  
SHOMREI HADATH SYNAGOGUE

PROJECT  
SHOMREI HADATH SYNAGOGUE

DRAWING TITLE  
CANOPY LAYOUT AND SECTION DETAILS

SIZE	SCALE	ORIGIN. ISSUE	DRAWN BY
A1	AS SHOWN	25.03.22	JH

PROJECT No.	TYPE	AREA-DWG No.	REV No.
05017	GA	01-01	-