

ALL DIMENSIONS, LEVELS AND CLEARANCES TO BE CHECKED ON SITE PRIOR TO WORKS COMMENCING

THIS DRAWING SHOULD BE READ IN CONJUNCTION WITH ALL OTHER PROJECT RELATED DRAWINGS, SPECIFICATIONS AND DOCUMENTS AS PART OF A SINGLE PROJECT PACKAGE.

ANY DISCREPANCY BETWEEN THIS DRAWING, OTHER DRAWINGS FORMING PART OF THIS CONTRACT, OR THE SPECIFICATION / BILLS OF QUANTITIES MUST BE CLARIFIED BEFORE COMMENCEMENT OF ANY WORK OR ORDERING OF ANY MATERIALS.

PLEASE CONSULT THE AUTHOR OR PROJECT MANAGER SHOULD THE READER REQUIRE CLARIFICATION ON ANY PART OF THIS DRAWING.

THE COPYRIGHT OF THE DRAWING AND DESIGN IS THE PROPERTY OF THE COMPANY. THIS INFORMATION HAS BEEN ISSUED UNDER SPECIFIC TERMS FOR THIS PROJECT AND MAY ONLY BE USED AND REPRODUCED ACCORDINGLY.

NOTES

P01	27.04.22	SEJ	BG	JM	Planning Issue
Rev	Date	By	Chk	Apr	Comment

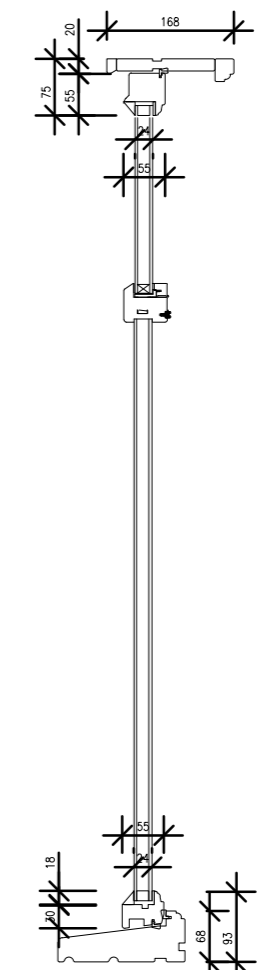
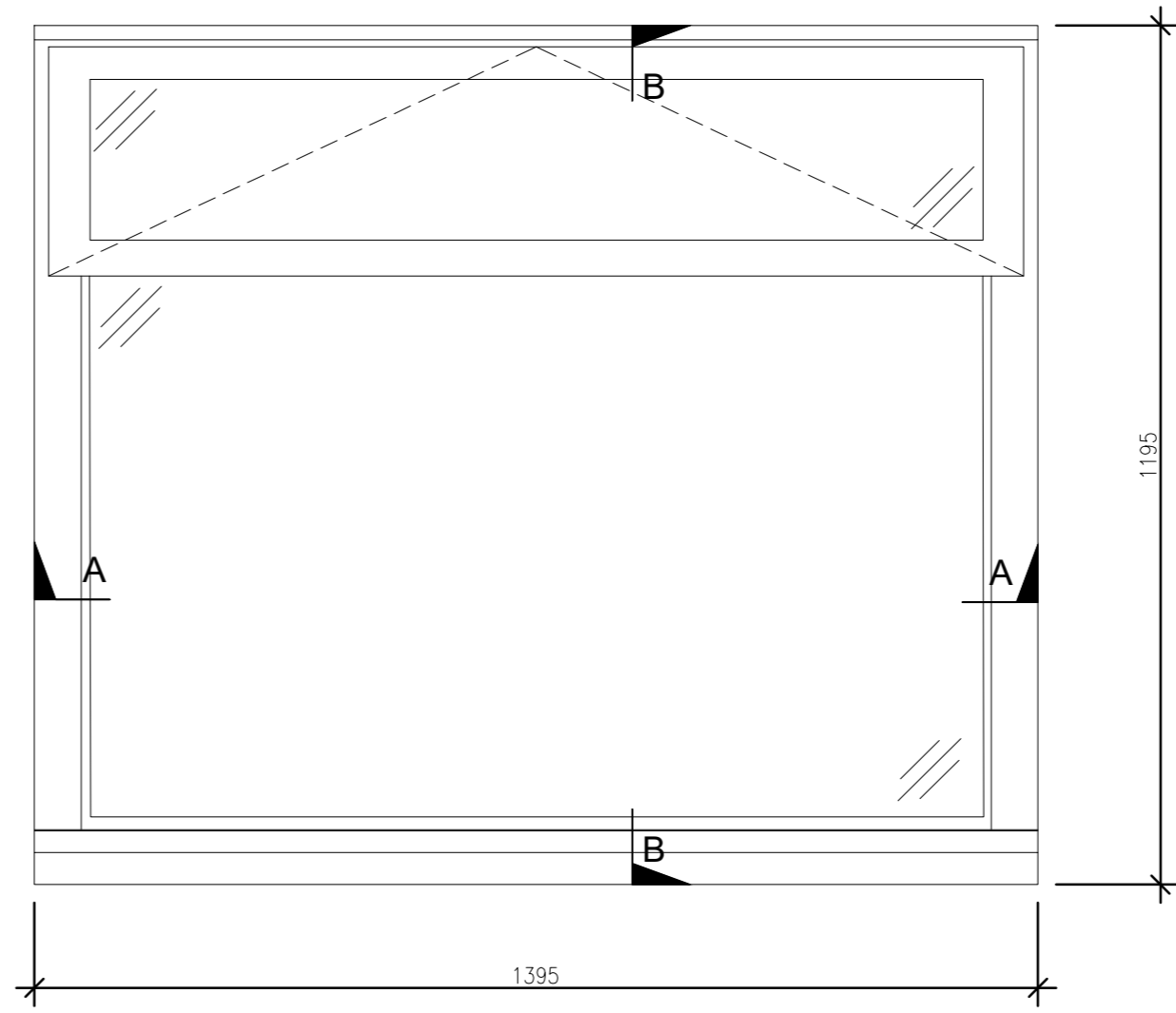
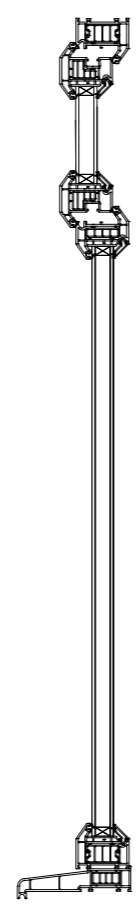
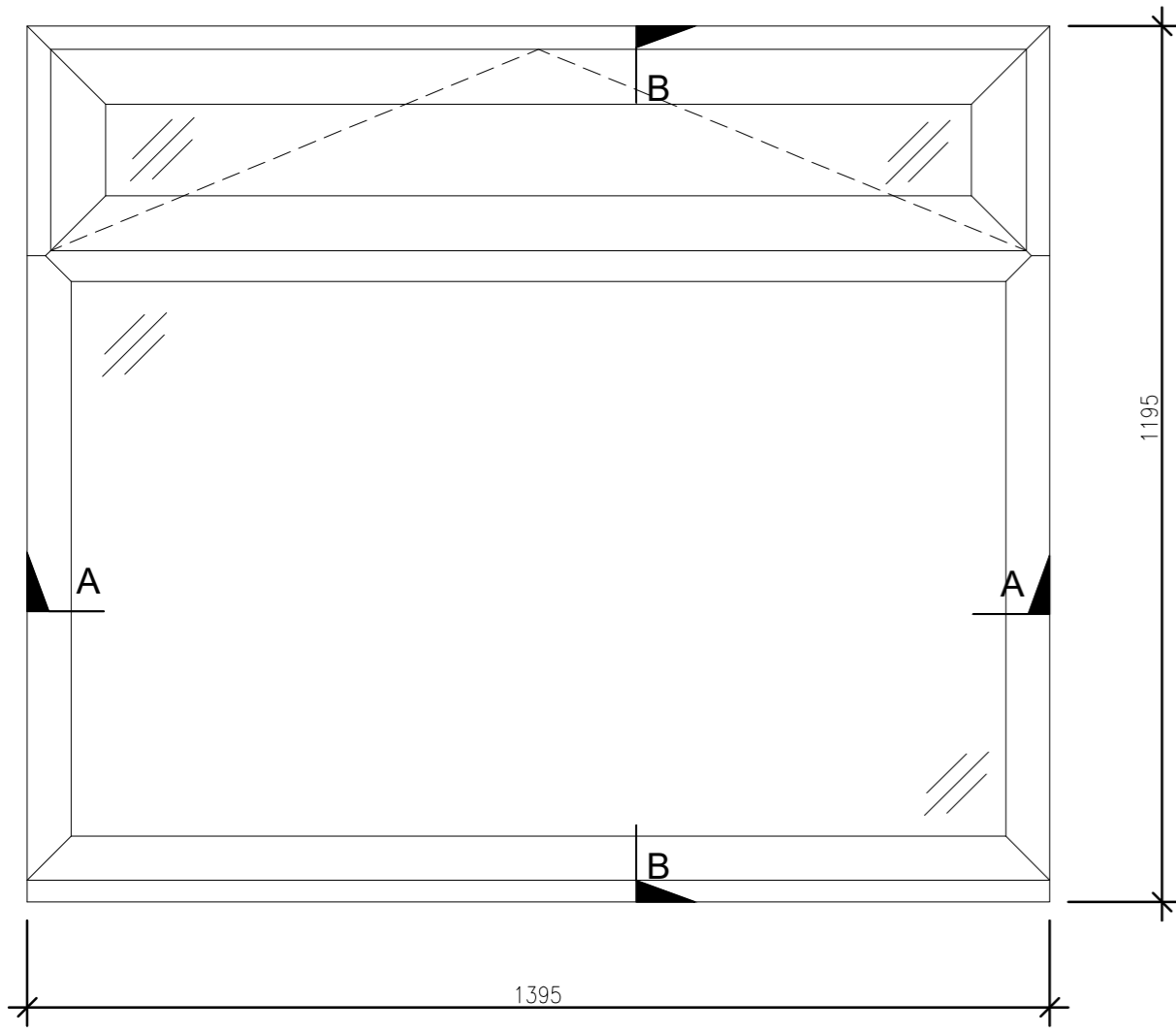

Elevation

Detail B

Elevation

Detail B

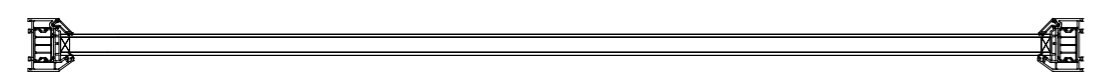

Detail A



Detail A

EXISTING TYPICAL uPVC TOP HUNG CASEMENT WINDOW DETAIL
Shown W08
Scale @ 1:10

PROPOSED TYPICAL TIMBER DOUBLE GLAZED TOP HUNG CASEMENT WINDOW DETAIL
Shown W08

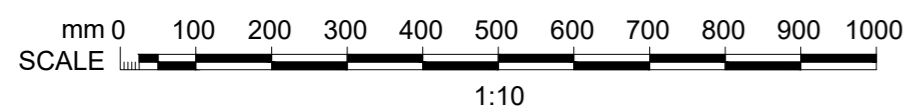

<p>BRINGING IDEAS TO LIFE</p>  <p>FRANKHAM</p> <p>Frankham Consultancy Group Limited E: enquire@frankham.com www.frankham.com</p>	
<p>SIDCUP OFFICE Irene House Five Arches Business Park Maidstone Road Sidcup, Kent DA14 5AE T: 020 8309 7777</p>	<p>OXFORD OFFICE Citibase Oxford New Barclay House 234 Botley Road Oxford OX2 0HP T: 01865 322500</p>
<p>LONDON OFFICE First Floor Bridge House 181 Queen Victoria Street London EC4V 4EG T: 020 7651 0790</p>	<p>STEVENAGE OFFICE Suite 237, Second Floor Kings Court Business Centre London Road, Stevenage Hertfordshire SG1 2NG T: 020 3714 7063</p>
<p>Client: AD Group</p>	
<p>Project Title: 91 Iverson Road, Camden, NW6 2QY Window Replacement Work</p>	
<p>Drawing Title: Existing and Proposed Window Details 2</p>	
<p>Status: PLANNING ISSUE</p>	

Drawn By: SEJ	Designed By: SEJ	Checked By: BG	Approved By: JM
Original Issue Date: 27/04/2022		Scale @ A2: 1:10	

Job No/ File Ref 228021	Originator FCG	Zone MB	Level EL
Type DR	Discipline B	Number 2401	Suitability S4
			Revision P01