

DO NOT SCALE THIS DRAWING
ALL DIMENSIONS MUST BE CHECKED ON
SITE BEFORE WORK COMMENCES

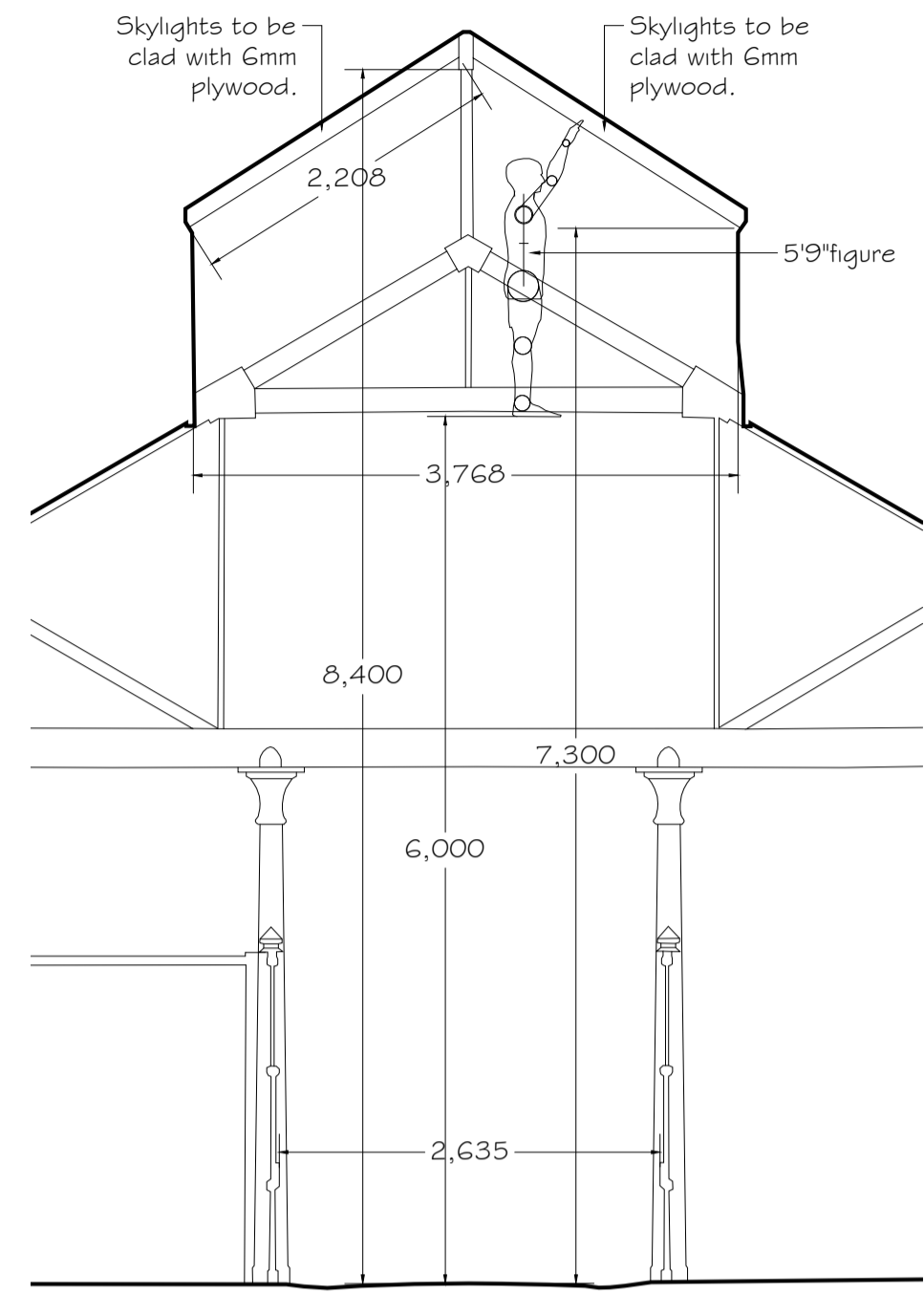

SECTION 1.50 scale

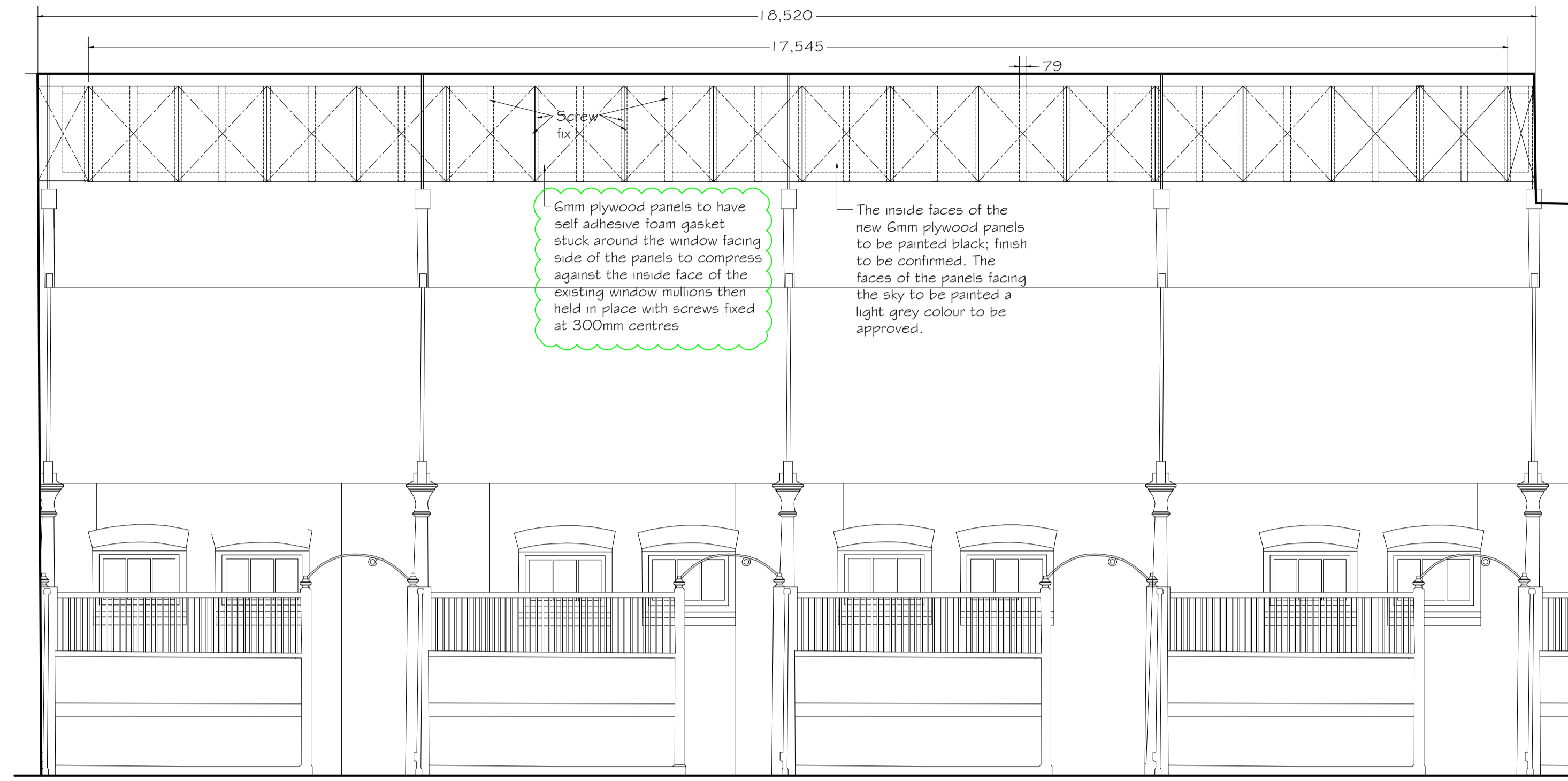

ELEVATION 1.50 scale NB: The mirror image of the above to be applied to the opposite elevation.

| No. | By | Revision | Date |
|-----|----|------------------------------------------------------|-----------|
| A | PB | Self adhesive foam gasket to panel fixing clarified. | 17 Apr 22 |

Job Title
Camden

Drawing Title
SKYLIGHT CLADDING DETAILS

| | | |
|--------------------------|--------------------------|----------------------|
| Scale 1.50 @ A1 | Drawing No. 22-714-06 | Rev. A |
| Drawn by Peter Bishop | Date 14 Apr 22 | Refer to Drawing No. |

