

Approximate top of  
 1841.00 AOD level  
 +136.30 AOD  
 PARAPET LEVEL  
 +138.19 AOD

23 Level  
 FFL +133.29 AOD

22 Level  
 FFL +130.04 AOD

21 Level  
 FFL +126.79 AOD

20 Level  
 FFL +123.54 AOD

19 Level  
 FFL +120.29 AOD

18 Level  
 FFL +117.04 AOD

17 Level  
 FFL +113.79 AOD

16 Level  
 FFL +110.54 AOD

15 Level  
 FFL +107.29 AOD

14 Level  
 FFL +104.04 AOD

13 Level  
 FFL +100.79 AOD

12 Level  
 FFL +97.54 AOD

11 Level  
 FFL +94.29 AOD

10 Level  
 FFL +91.04 AOD

09 Level  
 FFL +87.79 AOD

08 Level  
 FFL +84.54 AOD

07 Level  
 FFL +81.29 AOD

06 Level  
 FFL +78.04 AOD

05 Level  
 FFL +74.79 AOD

04 Level  
 FFL +71.54 AOD

03 Level  
 FFL +68.29 AOD

02 Level  
 FFL +65.04 AOD

01 Level  
 FFL +61.79 AOD

00 Level  
 FFL +58.54 AOD

-1 Level  
 FFL +52.45 AOD

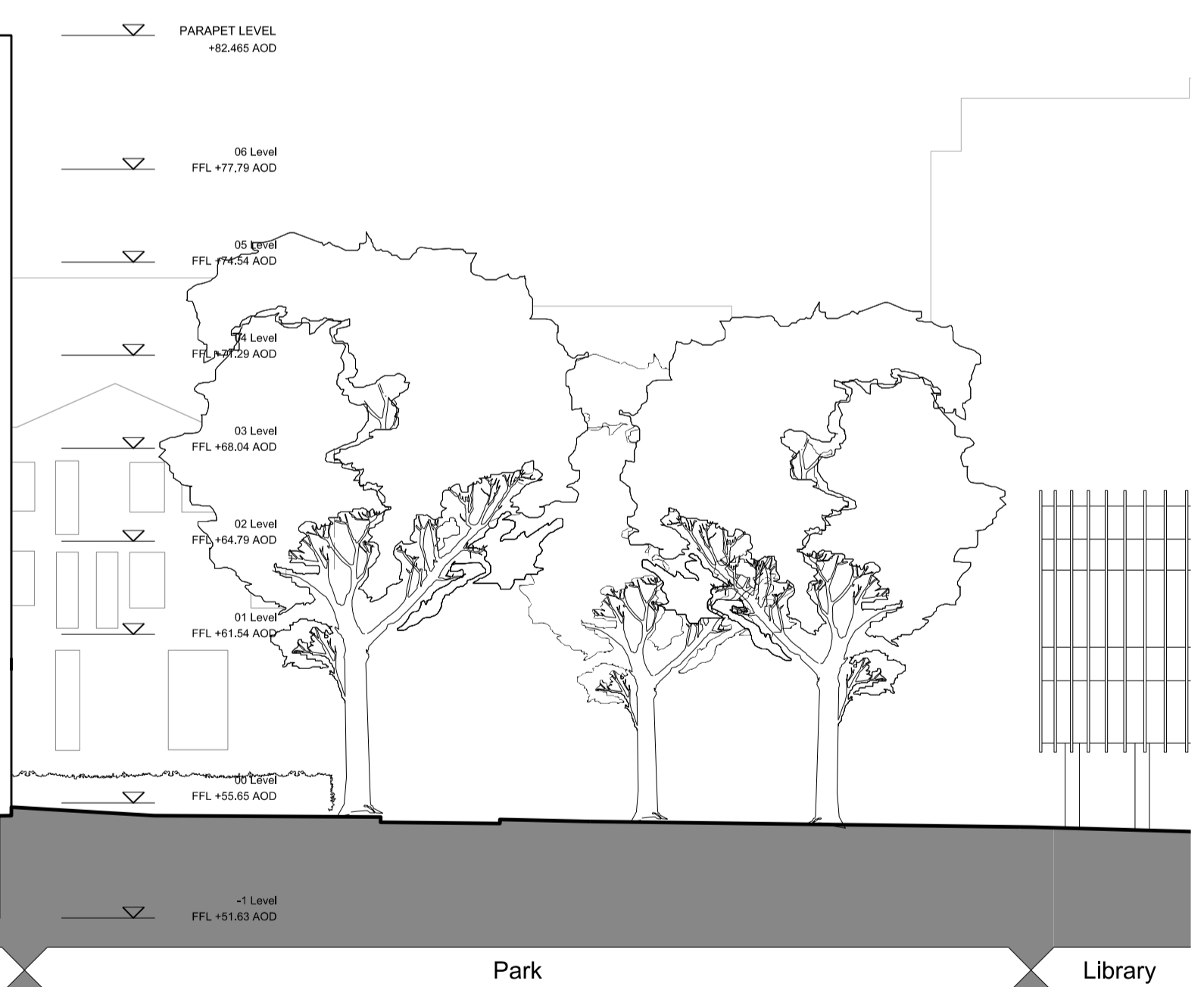
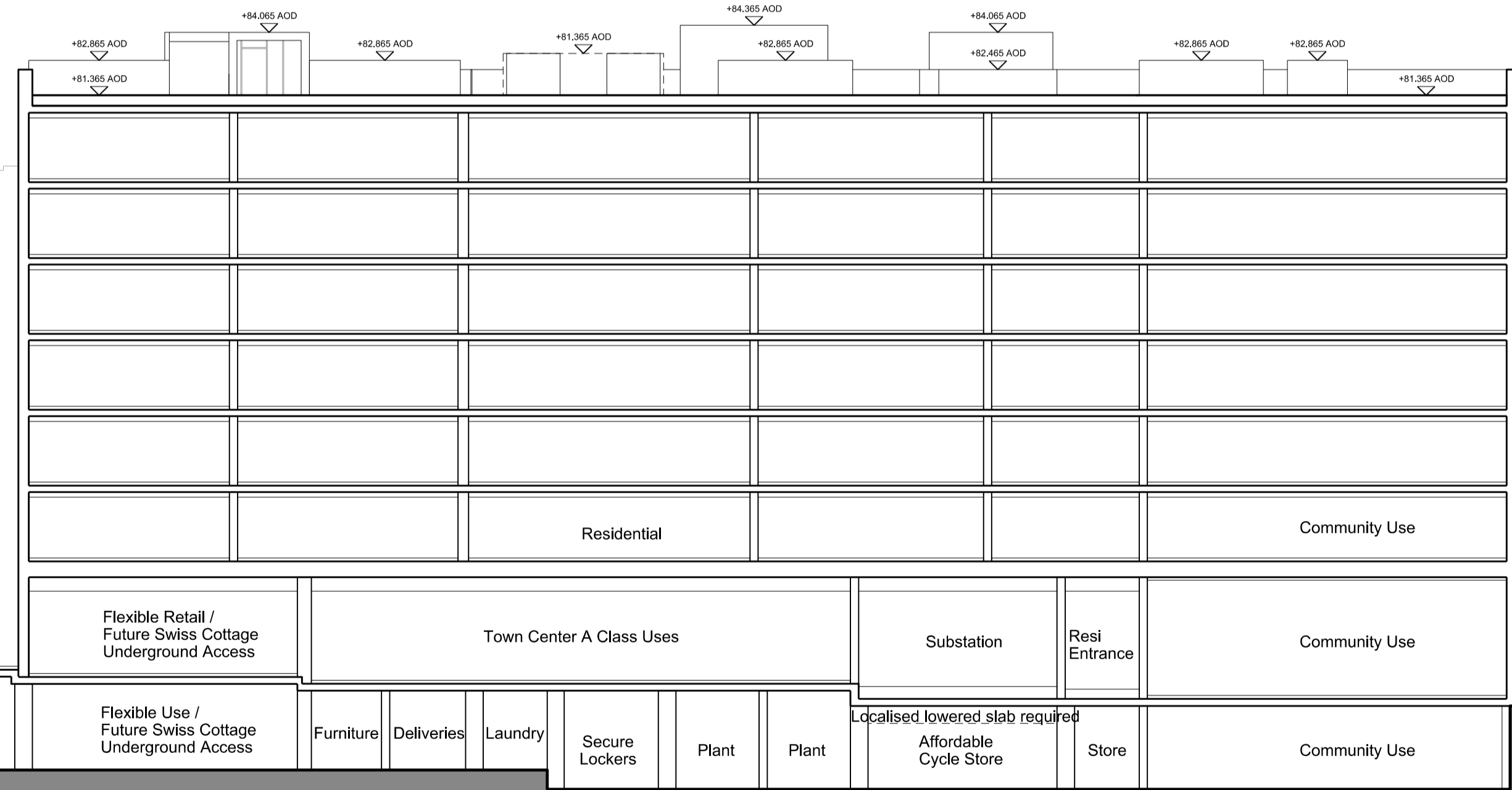
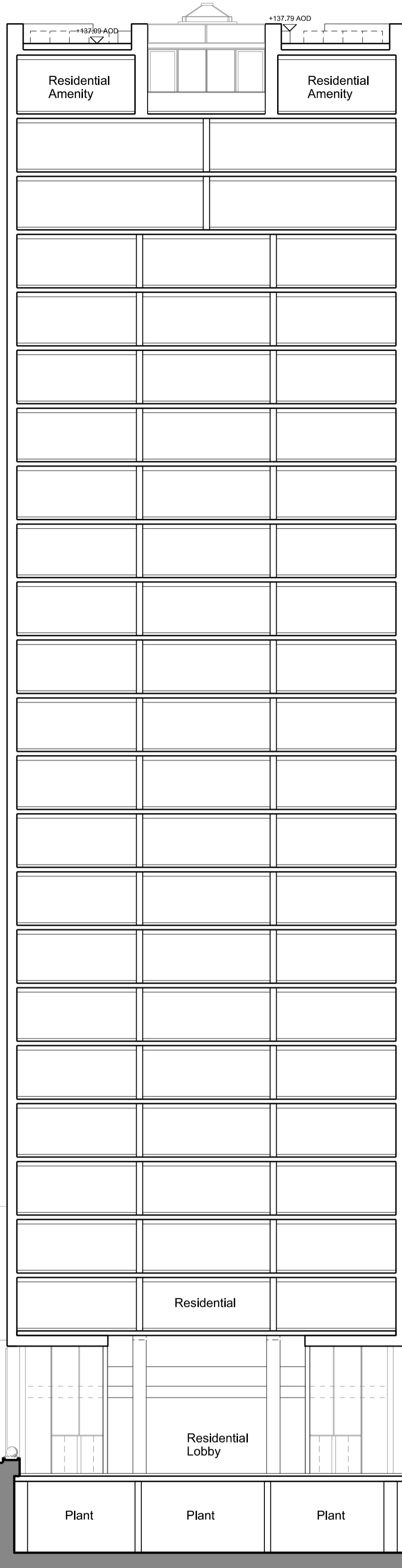

Market Store Site Park Library

**Disclaimer:**  
 Do not scale from this drawing.  
 Check all dimensions on site before fabrication or setting out.  
 This document is copyright and may not be reproduced without  
 permission of the owner.

**Notes:**  
 For Planning Purposes Only

Rev:	Notes:	Date:	Dwn:	Iss:
P1	Issued for Planning	28.02.14	mc	cc

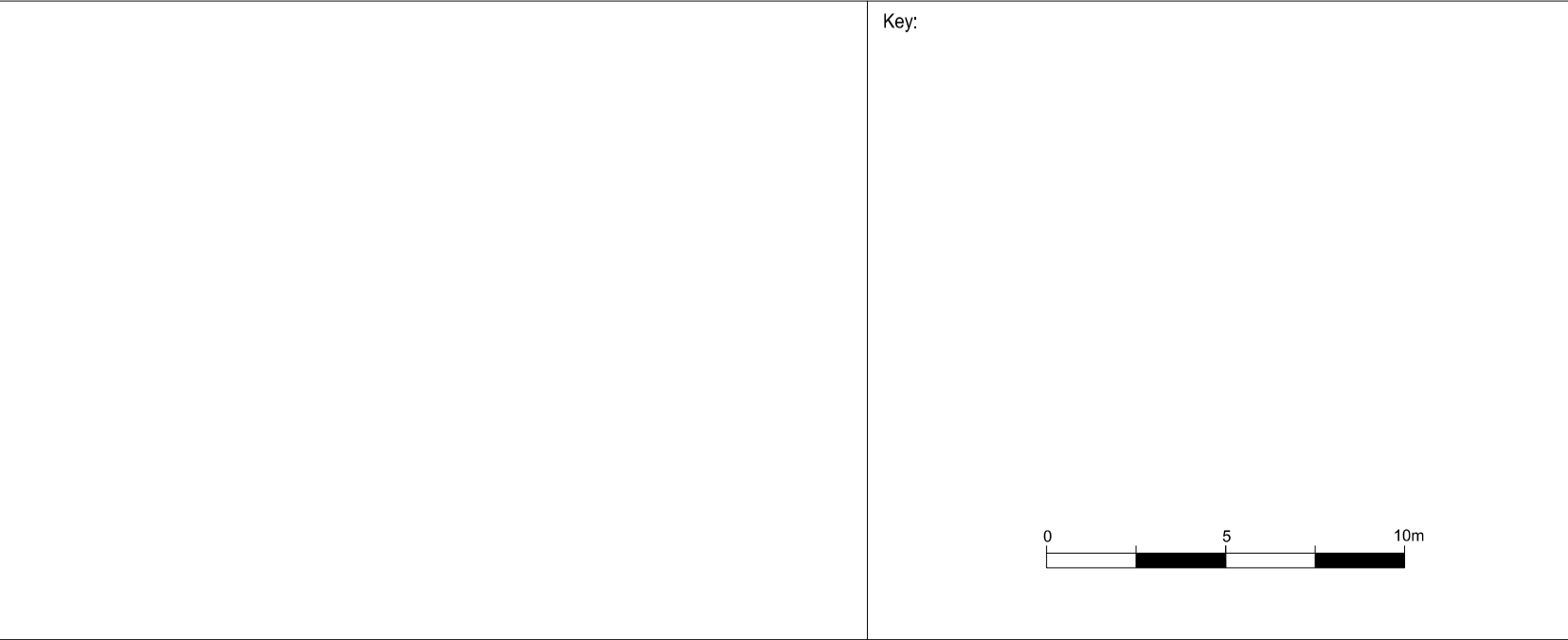

**GRID**  
 Architects // Masterplanners  
 128 Southwark Street,  
 London SE1 0SW  
 United Kingdom  
 T +44 (0) 20 7693 3260 E info@gridarchitects.co.uk W www.gridarchitects.co.uk

Client:  
**Essential Living**

Project: 100 Avenue Road, Swiss Cottage Residential led, mixed use development		
Drawing Title: Section 1 Northern and Southern Block		
Drawn By: MC	Issued By: CC	Date of First Issue: 28.02.14
Project No: 12064	Scale @ A1: 1:200	
Drawing No: PL_401	Revision: P1	

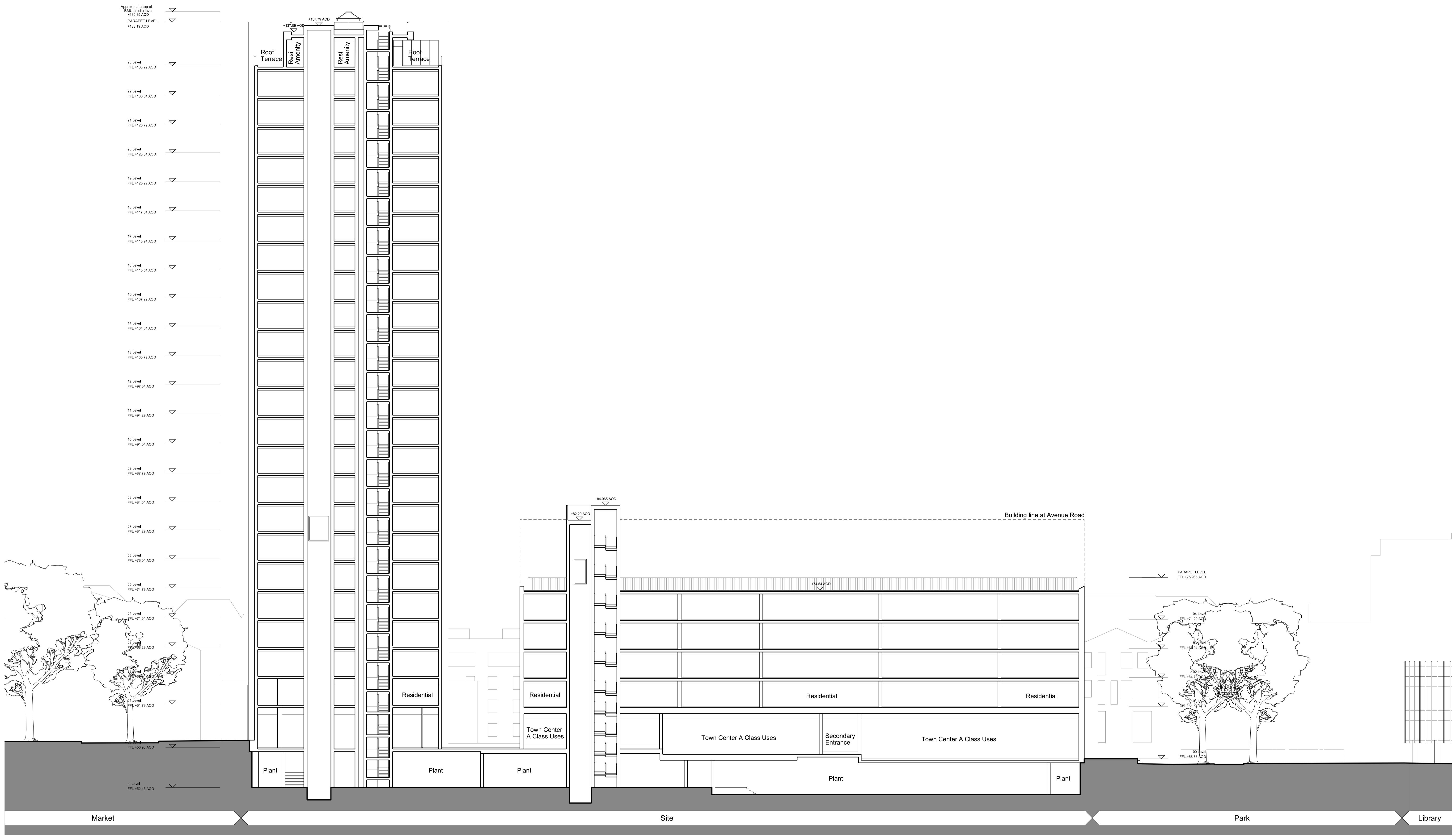

**Disclaimer:**  
Do not scale from this drawing.  
Check all dimensions on site before fabrication or setting out.  
This document is copyright and may not be reproduced without permission of the owner.

**Notes:**  
**For Planning Purposes Only**

Rev:	Notes:	Date:	Dwn:	Iss:
P1	Issued for Planning	28.02.14	mc	cc

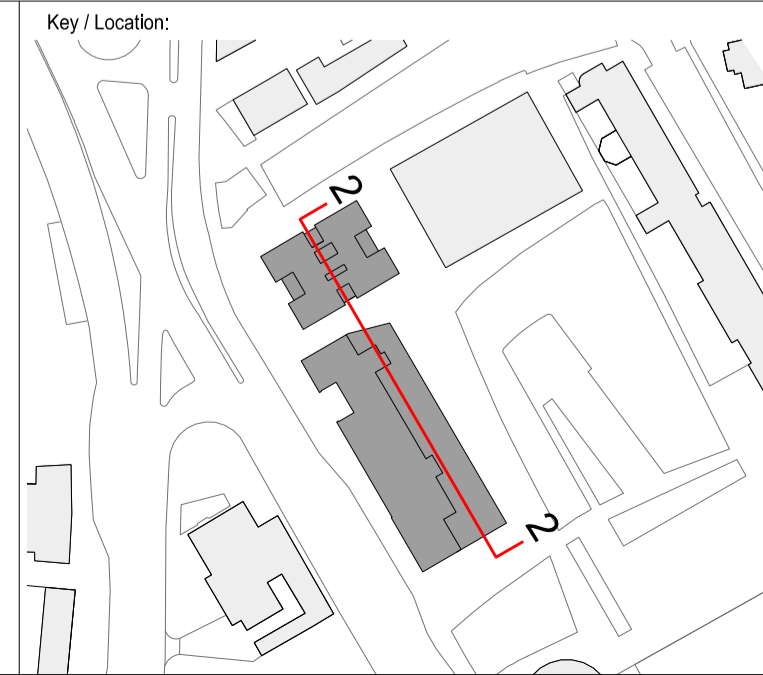
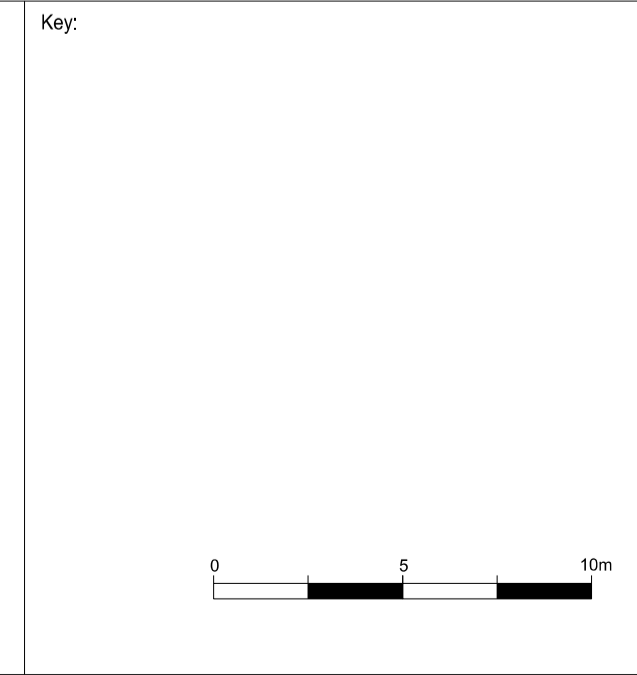

**GRID**  
Architects // Masterplanners  
128 Southwark Street,  
London SE1 0SW  
United Kingdom  
T +44 (0) 20 7633 3260 E info@gridarchitects.co.uk W www.gridarchitects.co.uk

Client:  
**Essential Living**

Project: <b>100 Avenue Road, Swiss Cottage Residential led, mixed use development</b>		
Drawing Title: <b>Section 2 Northern and Southern Block</b>		
Drawn By: MC	Issued By: CC	Date of First Issue: 28.02.14
Project No: 12064	Scale @ A1: 1:200	
Drawing No: PL_402	Revision: P1	

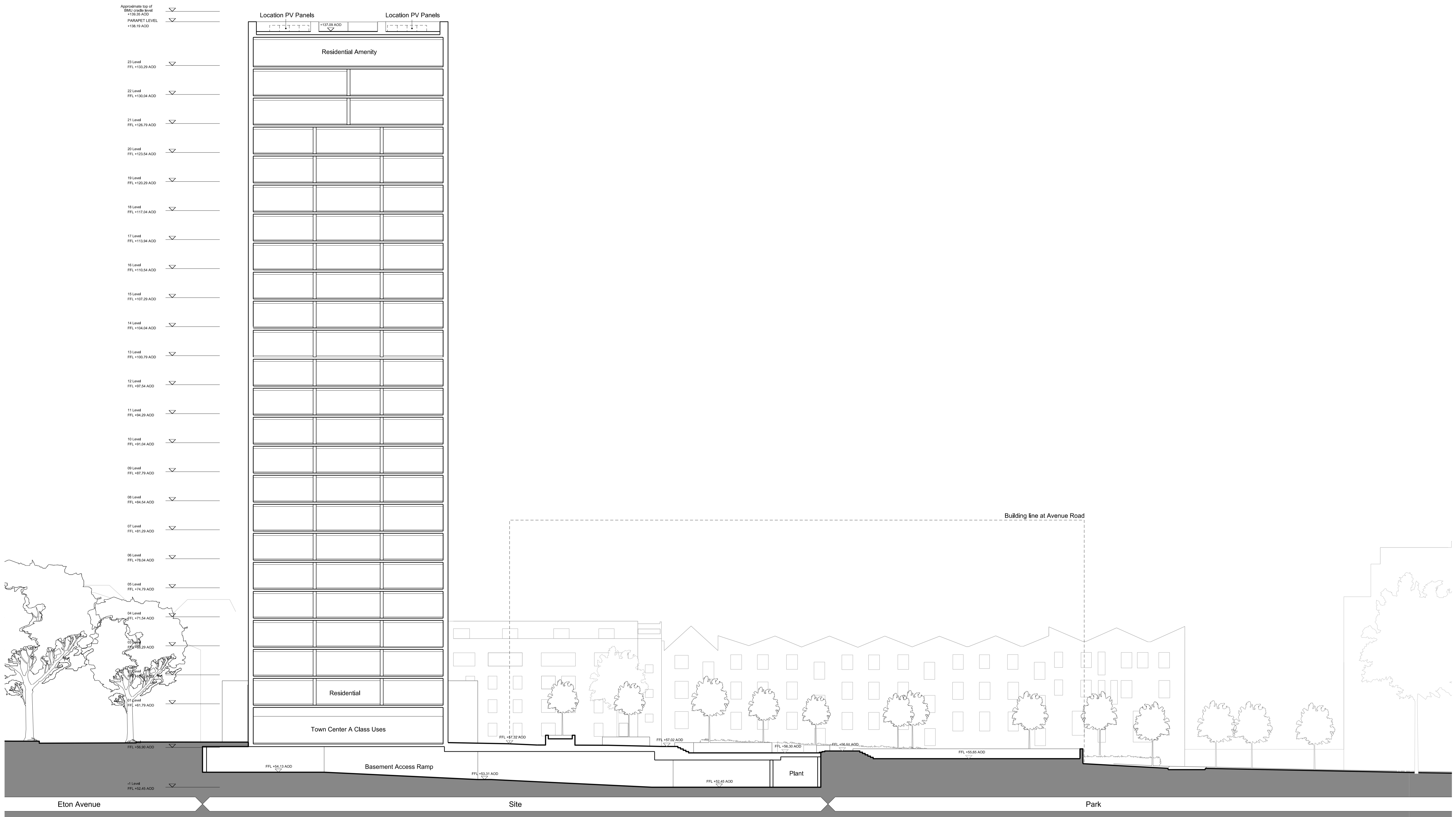

**Disclaimer:**  
Do not scale from this drawing.  
Check all dimensions on site before fabrication or setting out.  
This document is copyright and may not be reproduced without permission of the owner.

**Notes:**  
**For Planning Purposes Only**

Rev:	Notes:	Date:	Dwn:	Iss:
P1	Issued for Planning	28.02.14	mc	cc

Key:									
------	--	--	--	--	--	--	--	--	--

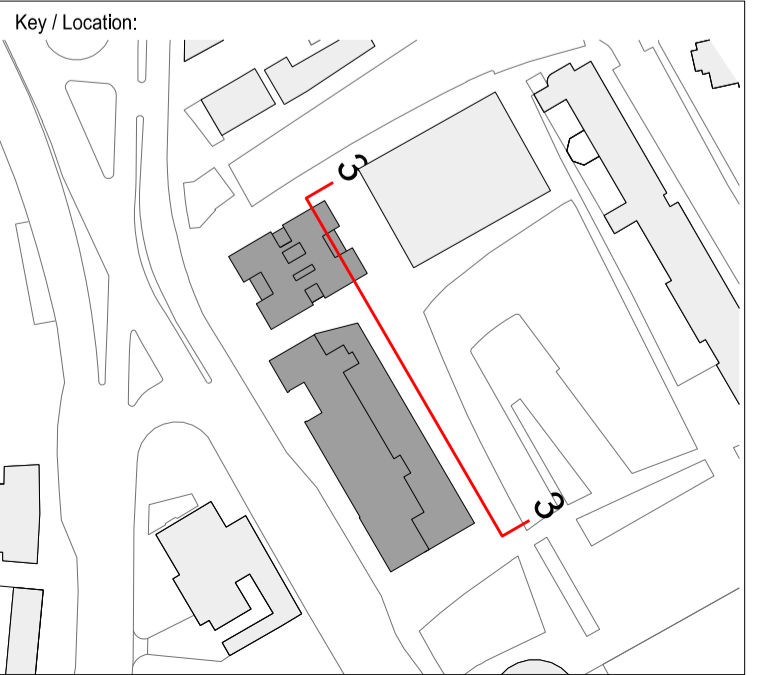
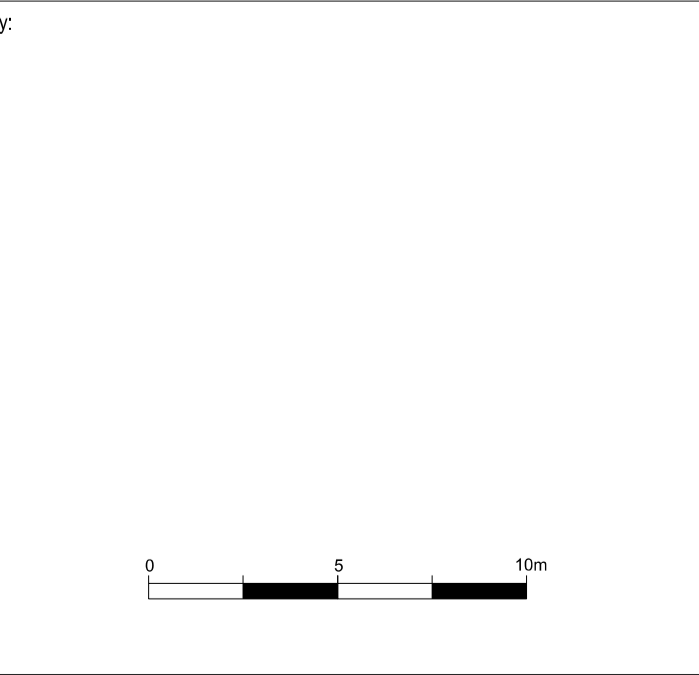

**GRID**  
Architects // Masterplanners  
128 Southwark Street,  
London SE1 0SW  
United Kingdom  
T +44 (0) 20 7693 3260 E info@gridarchitects.co.uk W www.gridarchitects.co.uk

Client:  
**Essential Living**

Project: <b>100 Avenue Road, Swiss Cottage Residential led, mixed use development</b>		
Drawing Title: <b>Section 3 Northern Block</b>		
Drawn By: MC	Issued By: CC	Date of First Issue: 28.02.14
Project No: 12064	Scale @ A1: 1:200	
Drawing No: PL_403	Revision: P1	

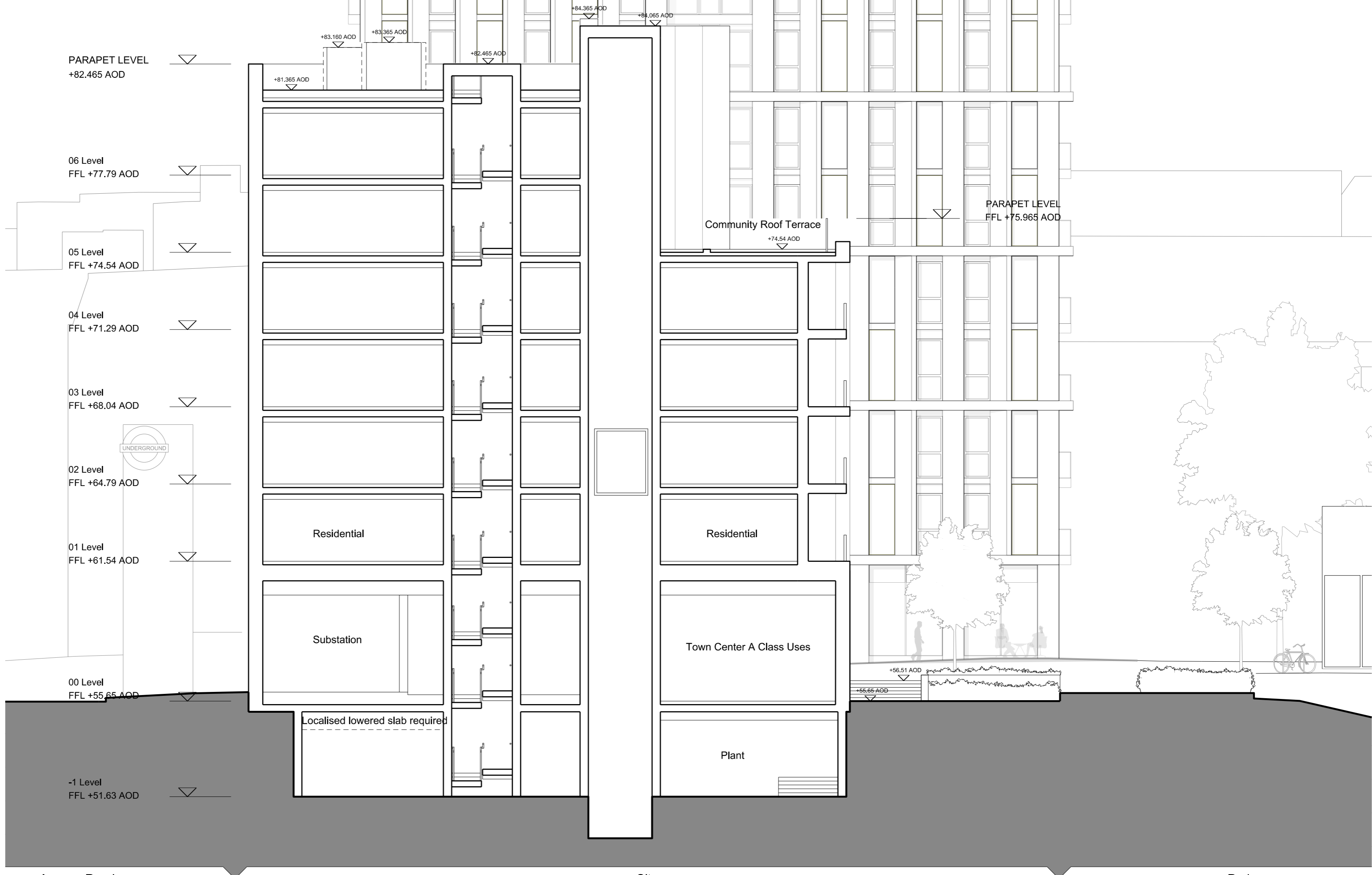
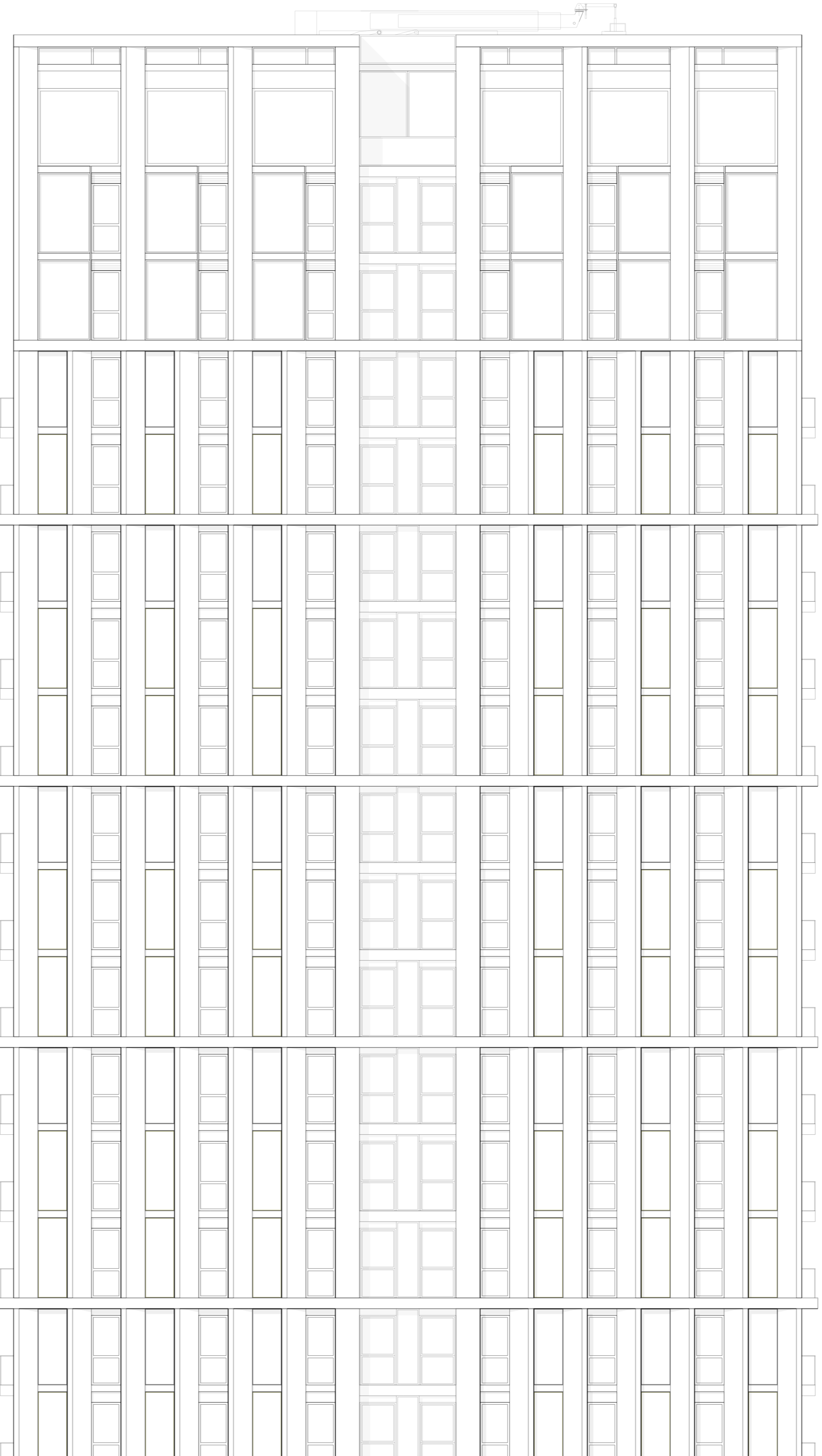

**Disclaimer:**  
Do not scale from this drawing.  
Check all dimensions on site before fabrication or setting out.  
The copyright in this drawing is reserved and may not be reproduced without permission of the owner.

**Notes:**  
**For Planning Purposes Only**

Rev:	Notes:	Date:	Dwn:	Iss:
P1	Issued for Planning	28.02.14	m/c	CC

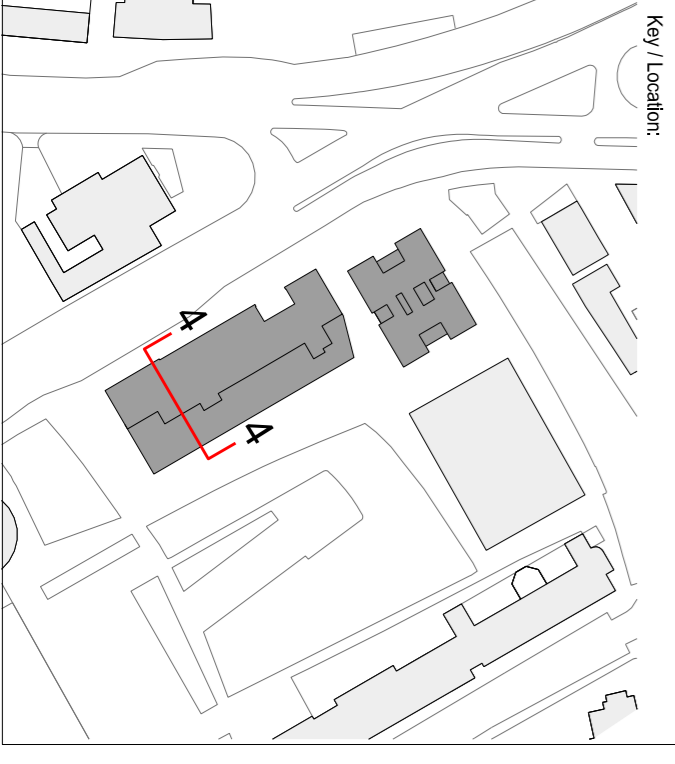
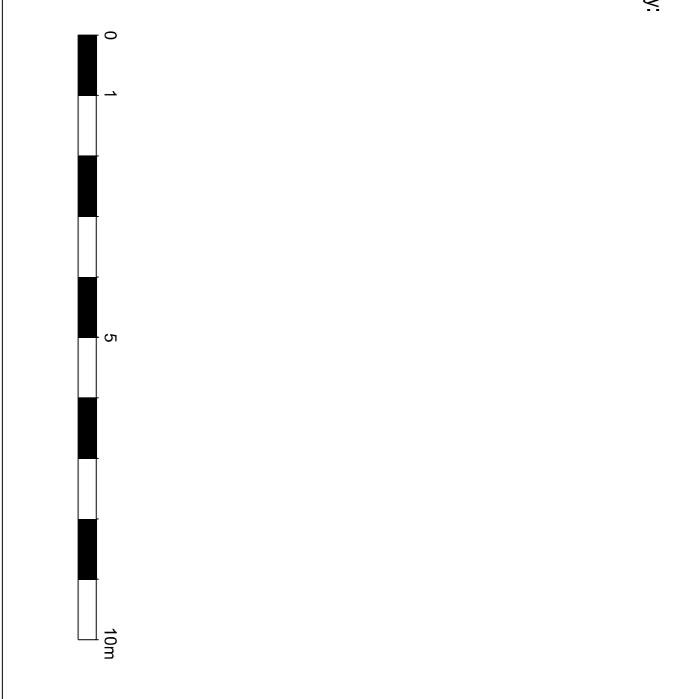

**GRID**  
Architects / Masterplanners

128 Southwark Street  
London SE1 1SW  
T: +44 (0) 20 7593 3200 E: info@gridarchitects.co.uk W: www.gridarchitects.co.uk

**Essential Living**

Project:	100 Avenue Road, Swiss Cottage Residential led, mixed use development
Drawn By:	M/C
Project No:	12064
Scale @ A1:	1:125
Issue:	CC
Date of First Issue:	28.02.14
Revision:	P1

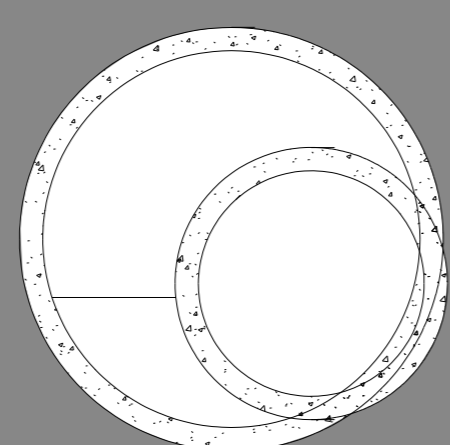





**Disclaimer:**  
Do not scale from this drawing.  
Check all dimensions on site before fabrication or setting out.  
The information on this drawing is for information only and may not be reproduced without permission of the owner.

**Notes:**  
For Planning Purposes Only

Rev: P1  
Notes: Issued for Planning  
Date: 28.02.14  
Dwg: mc  
Iss: cc

Key:



Key/Location:

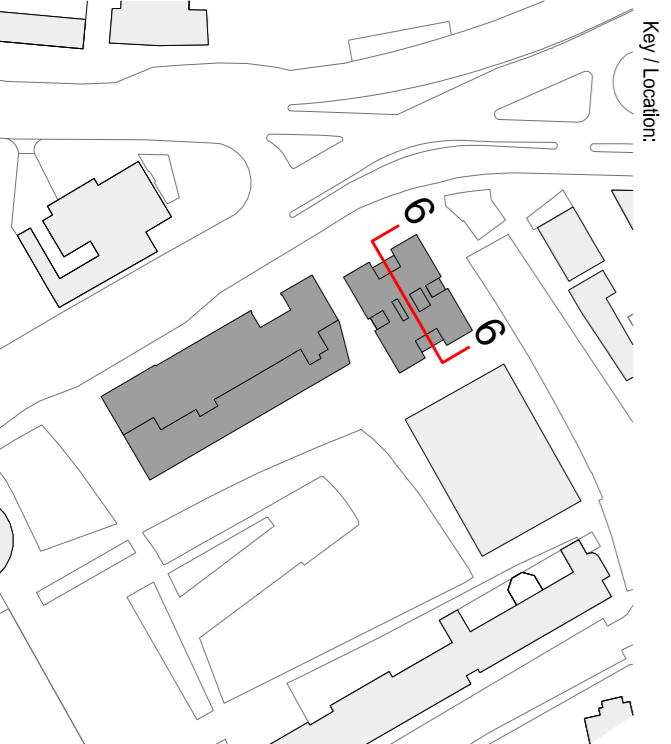

**GRID**  
Architects / Masterplanners  
128 Southwark Street  
London SE1 1SW  
T: +44 (0) 20 7593 3200 E: info@gridarchitects.co.uk W: www.gridarchitects.co.uk

**Essential Living**

Project:  
100 Avenue Road, Swiss Cottage  
Residential led, mixed use development

Section 6  
Tower

Drawn By: MC  
Issued By: CC  
Date of First Issue: 28.02.14

Project No: 12064  
Scale @ A1: 1:125

Drawing No: PL\_406  
Revision: P1

- Approximate top of BMU cradle level +139.35 AOD
- PARAPET LEVEL +138.19 AOD
- 23 Level FFL +133.29 AOD
- 22 Level FFL +130.04 AOD
- 21 Level FFL +126.79 AOD
- 20 Level FFL +123.54 AOD
- 19 Level FFL +120.29 AOD
- 18 Level FFL +117.04 AOD
- 17 Level FFL +113.94 AOD
- 16 Level FFL +110.54 AOD
- 15 Level FFL +107.29 AOD
- 14 Level FFL +104.04 AOD
- 13 Level FFL +100.79 AOD
- 12 Level FFL +97.54 AOD
- 11 Level FFL +94.29 AOD
- 10 Level FFL +91.04 AOD
- 09 Level FFL +87.79 AOD
- 08 Level FFL +84.54 AOD
- 07 Level FFL +81.29 AOD
- 06 Level FFL +78.04 AOD
- 05 Level FFL +74.79 AOD
- 04 Level FFL +71.54 AOD
- 03 Level FFL +68.29 AOD
- 02 Level FFL +65.04 AOD
- 01 Level FFL +61.79 AOD
- 00 Level FFL +56.90 AOD
- 1 Level FFL +52.45 AOD

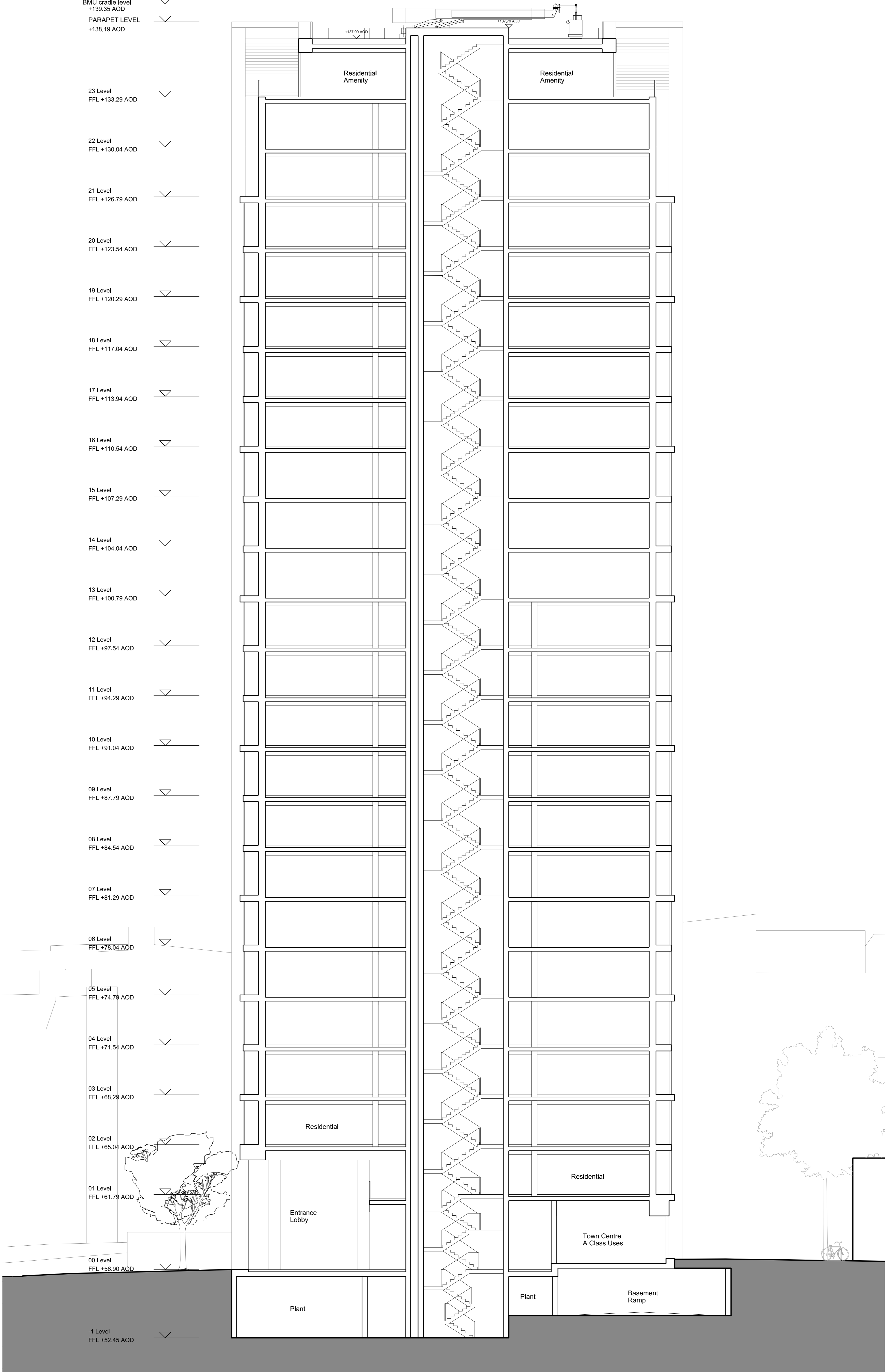

Avenue Road

Site

Path

Theatre

