

01 Plan D-D
3002 1:20 @ A3

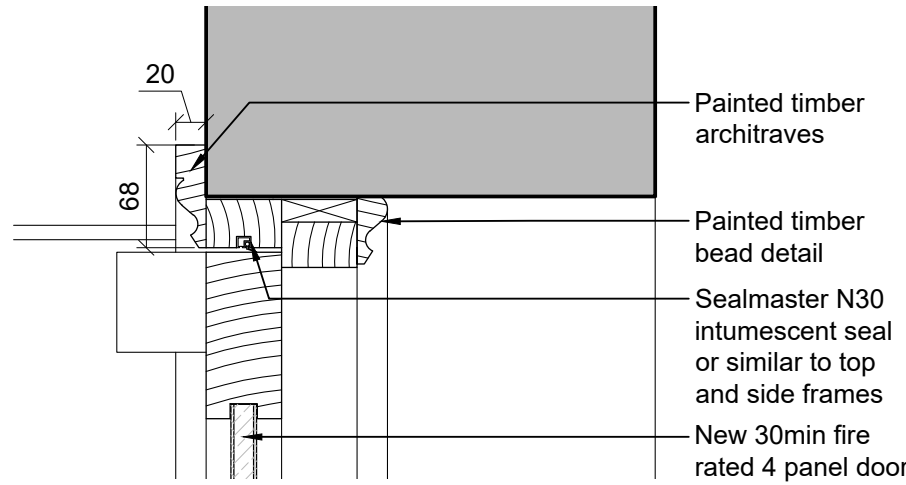

02 Door Head
3002 1:5 @ A3

NOTES:

1. Drawings based on survey by others.
2. Drawings to be read in conjunction with all schedules and specification.
3. Dimensions to be confirmed on site
4. Refer to M&E Engineer's specifications and proposals.
5. Refer to Structural Engineer's specifications and proposals for all structural work.
6. Notify architect in writing of any discrepancies or omissions.
7. Survey information by others. All existing dimensions to be confirmed on site.
8. Drawing is not to be used for construction.
9. All works subject to Listed Building Consent.
10. New doors of an appropriate style for the hierarchy of the building, complete with door heads, linings and frames. Existing architraves to be replaced with new of an appropriate style where noted.
11. Allow for the production of full working shop drawings to be undertaken by a specialist sub-contractor for the review and approval of the Historic Buildings Architect.
12. All door dimensions based on site survey and survey drawings. Structural door openings to be measured on site by contractor.
13. All details are to be approved by the Building Regulations Approved Inspector.
14. On fielded panel doors - top panels to be taller or equal to lower panels.

DRAWING FOR DESIGN PURPOSE ONLY. ENSURE DOOR MEETS FIRE RATING AS PER DOOR SCHEDULE 6000

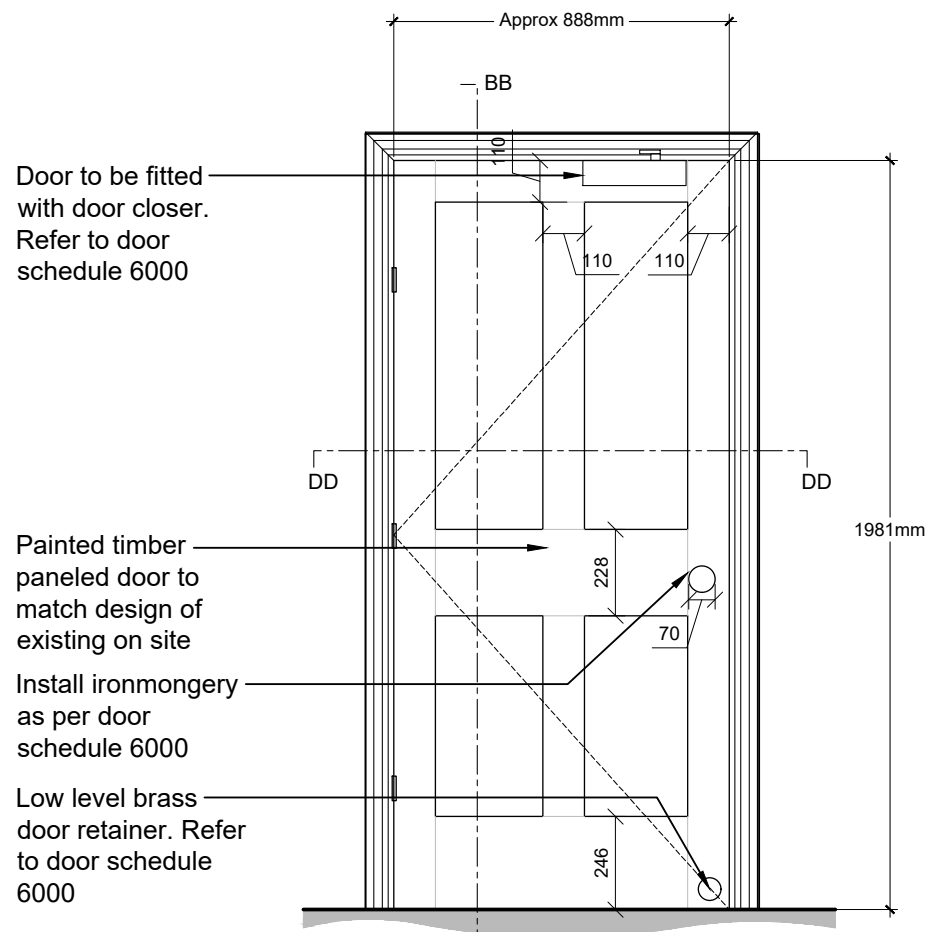

03 Door Elevation AA
3002 1:20 @ A3

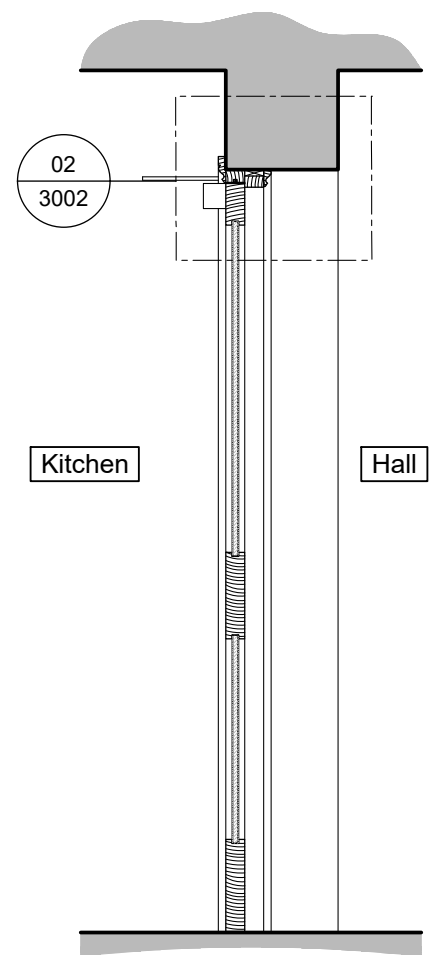

04 Door Section B-B
3002 1:20 @ A3

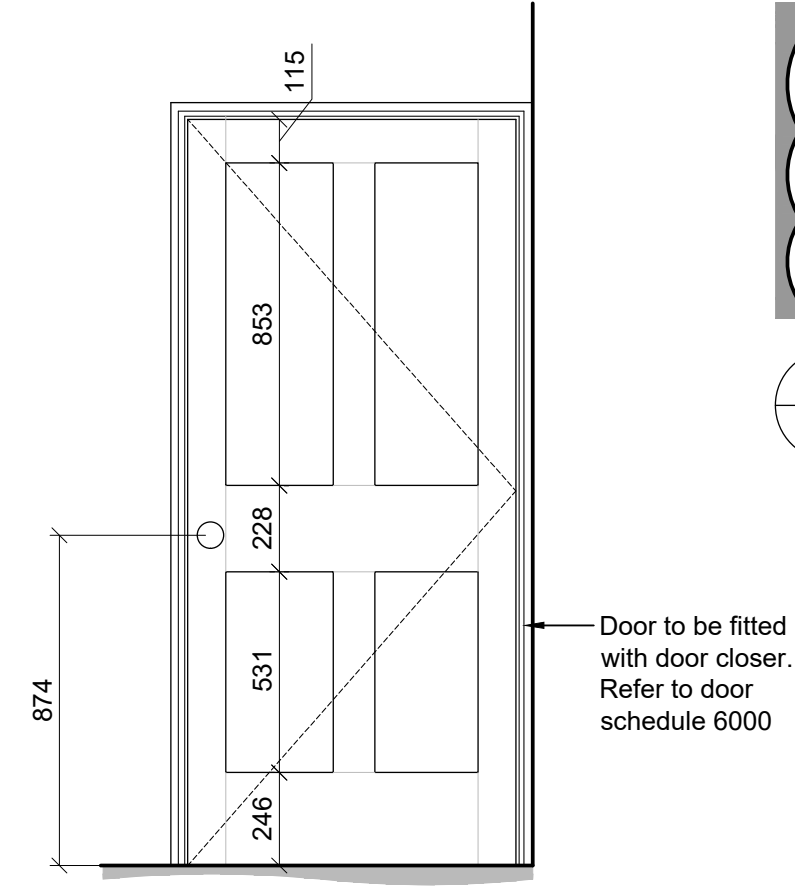

05 Door Elevation C-C
3002 1:20 @ A3

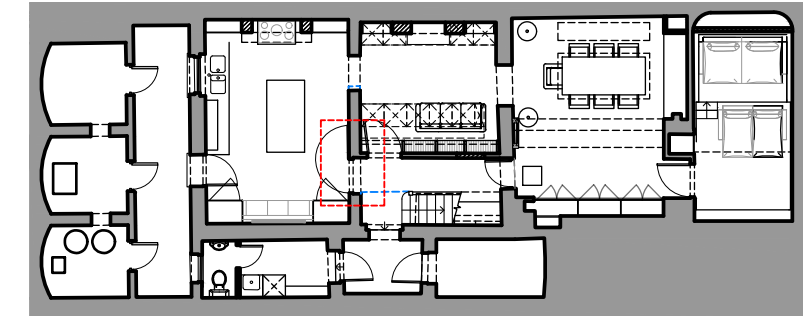

00 Basement Key Plan
3002 1:200 @ A3

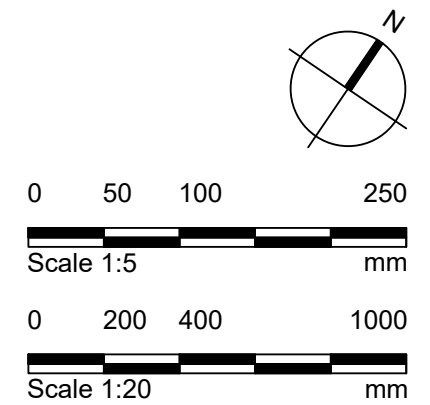

Purpose of Issue:
FOR_TENDER

Notes
1. Any dwg format drawing is to be read in conjunction with and at the scale of the accompanying pdf.
2. Where colours other than black or grey are used, the drawing must be plotted in colour.
3. For status 'C' (Construction) drawings all dimensions are to be checked on site by the contractor, scaling is for Local Authority purposes only.
4. Unless otherwise indicated, all dimensions are in millimeters.
5. All information on this drawing is to be read in conjunction with the relevant Donald Insall Associates specification and trade contractors' drawings and information by specialists.
6. In the event of any discrepancy, please contact us immediately.
7. This drawing may contain survey information by others and is to be used solely for the purposes for which it was issued.
8. These are uncontrolled documents issued for information purposes only. If you have any queries regarding the drawings, please contact DIA immediately.
9. Please note DIA cannot be held responsible for any errors arising from changes made to an uncontrolled dwg file.

Rev	Date	Dwn	Auth	Revision
0	28-01-22	HZC	JXT	Tender Issue

Donald Insall Associates
Chartered Architects and Historic Building Consultants

12 Devonshire Street
London W1G 7AB
(+44) 020 7245 9888
london@insall-architects.co.uk

1 Crestfield Street

Project	CS1.01	No	3002
Scale (A3)	1:100	Status	4T
		Revision	0

Kitchen Door BD06
As Proposed