

LANDSCAPE ELEMENTS: refer to hard landscape plan SP108_04_HL & to relevant engineer's information
CYCLE STANDS - 14no. providing 28 spaces

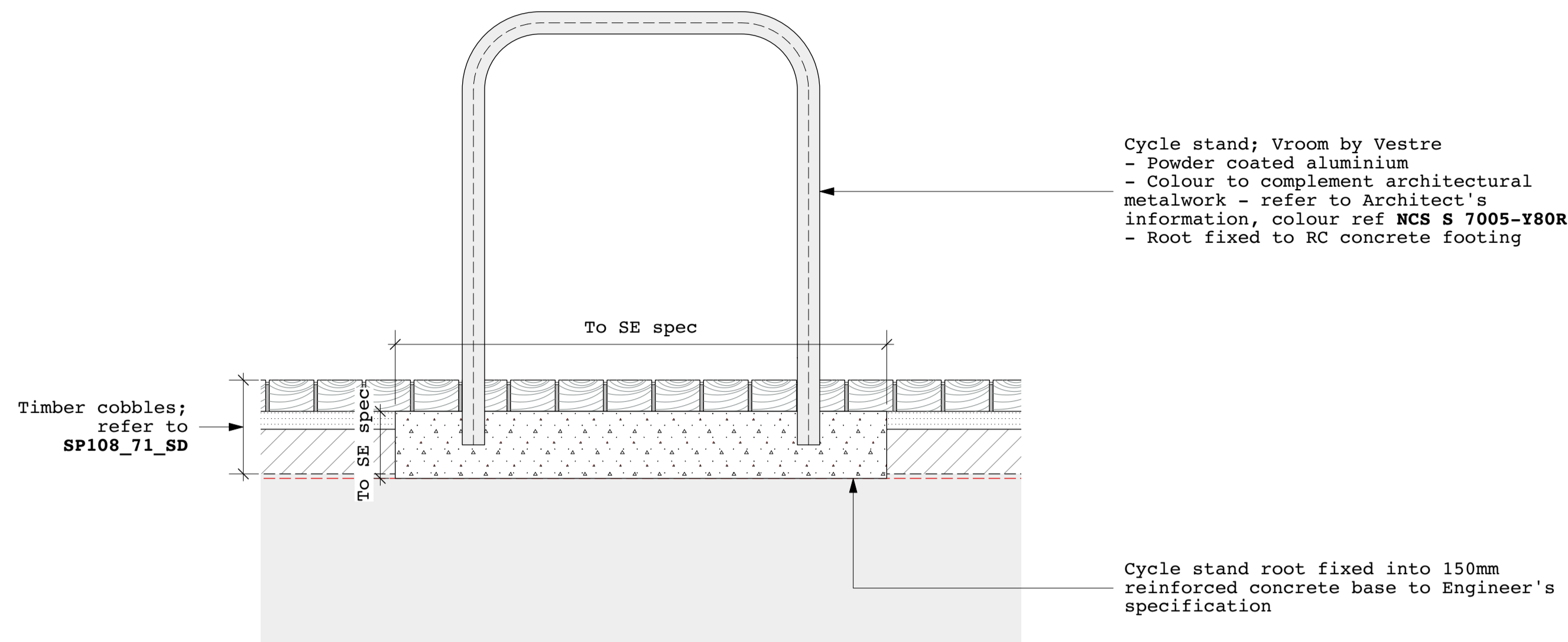

LITTER BINS - 2no.

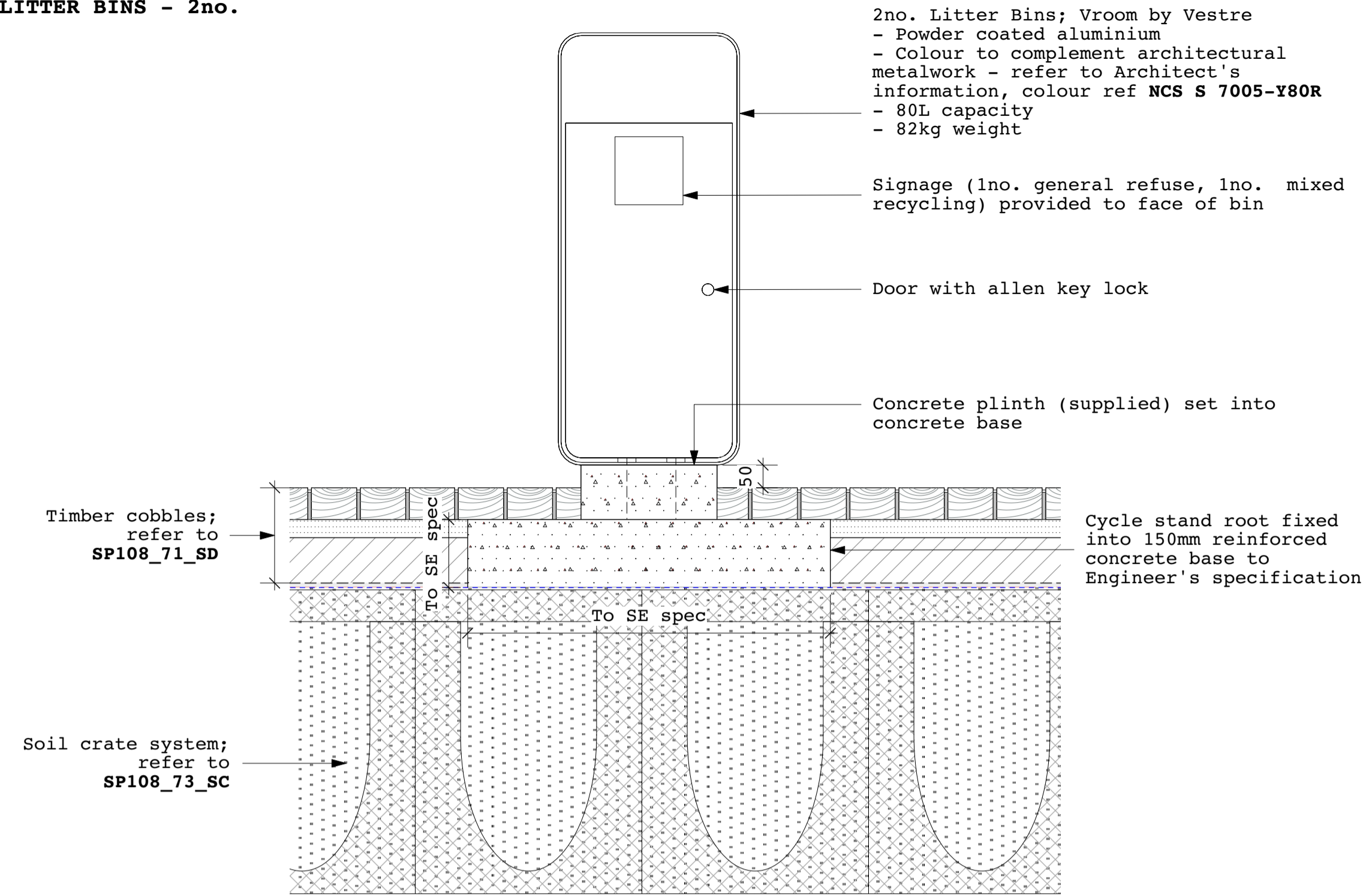

For surfaces key and areas, refer to hard landscape plan: SP108_04_HL

© JCLA

Do not scale from this drawing. Any discrepancies or queries should be brought to the attention of the authors. Dimensions are to be verified on site prior to construction.

All existing site, tree and building information has been compiled from different sources.

Refer to current revisions of all referenced files.

Notes:

IRRIGATION STANDPOINTS, 2no.: refer to hard landscape plan SP108_04_HL & to relevant engineer's information

- Supplier: Arrow Valves
- Model SPTB - Miniature standpipe for soft ground (overall height 288mm, tap height 176mm)
- Refer to drainage information for supply/ducting requirements

Miniature Standpipe Model SPTB – Miniature Standpipe – Soft Ground - Datasheet

Description

Tamperproof outside hose tap in stainless steel enclosure, with spherical type angled valve and hose connector. The SPTB has a hinged tap cover, which can be secured with a padlock, to prevent misuse or tampering.

The permanent low level Standpipe is designed to be buried in soft ground – such as flower beds. The height from the outlet to ground complies with the Water Regulations. The outlet is horizontal, which is ideal for a hose pipe. See SPTG or SPED if bucket filling required.

The housing includes foam insulation, which provides a reasonable level of frost resistance for the valves and pipe.

The Standpipe features a Double Check Valve providing Fluid Category 3 protection. A servicing valve is also supplied and all serviceable components are accessible from the front.

Specification

Pressure Supply	10 bar maximum
Inlet	20 or 25 MDPE or 22 mm Cu
Outlet	Inter-Lock Plug (quick release) (compatible with Hozelock)
Box material	304 Stainless Steel (bright)
Water Regulations Approval	1303701

Applications

Model SPTB incorporates a Double Check Valve (ED device) and is suitable for Fluid Category 3 applications. This low-level standpipe is specifically designed for discreet flower bed installation – a hose can be attached. For installing on a hard flat surface - see model SPTG.

Dimensions

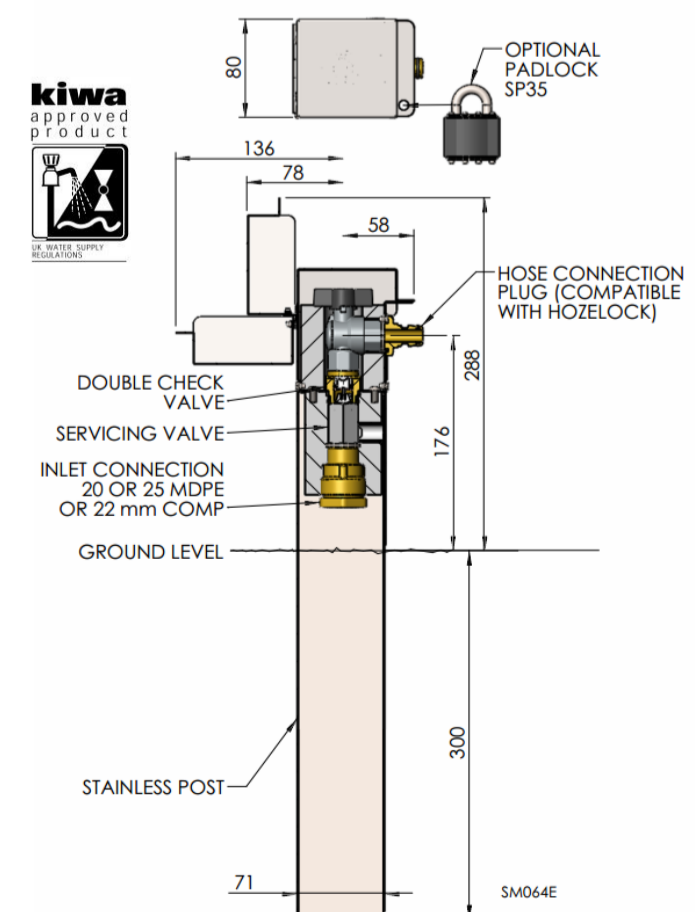

Service

The spherical valve features maintenance free PTFE seats. It is possible to tighten or replace the spindle PTFE seal. A servicing valve is provided, accessible through the front cover.

Water Regulations

The Double Check Valve fitted provides adequate protection against Fluid Category 3 risks.

Options

Padlocks – high anti rust, model SP35 supplied with 2 keys or code SPCP1 has four digit combination.

Hose connector sockets – Brass quick release coupling for connecting a hose to the Tap Box outlet plug. Codes - HUG7903 (1/2"), HUG7933 (3/4"). Note hose connector plug is common to 1/2" and 3/4" Tap Boxes. Compatible with Hozelock.

Shield - Hose Connection/DB Pipe Interrupter Shield – code HUSHIELD with lock plate. Stainless steel tube that covers the brass hose connector. The Shield is secured with a lock plate inside the box, which is inaccessible once the cover is padlocked. Fits all models.

Male Outlet – The 1/2" Tap Box is normally supplied with Hozelock compatible hose plug outlet. A conventional 1/4" male thread with removable hose plug is available – code HUG791575M.

Codes and Descriptions

Size	Code	Description
DN15	SPTB15X20	1/2" Miniature Standpipe Ground 20 MDPE
DN15	SPTB15X25	1/2" Miniature Standpipe Ground 25 MDPE
DN15	SPTB15X22	1/2" Miniature Standpipe Ground 22 Comp
	SP35	Padlock 2 Keys KA - Silver Shackle
	SPCP1	Square Padlock Combination - High Anti Rust
1/2"	HUG791575M	Male Outlet (1/2") and Hose Plug - 1/2" Tap Box
DN15	HUG7903	Hose Connector/Inter-Lock Socket
	HUSHIELD	Hose Connector/DB Pipe Interrupter Shield
	DB20LS15	Pipe Int. DB HUSHIELD 1/2" Hose Connector
DN15	HUG7943	Spray Gun Medium Duty Var. Vol Inter-Lock
DN15	HU19NTB1	Washdown Gun Heavy Brass Inlock Hose Con.

Arrow Valves Ltd
 Tel: 01442 823123 Fax: 01442 823234
 www.arrowvalves.co.uk

Arrow Valves Ltd reserve the right to change specifications, design and materials at any time without notice.
 All unit-less dimensions in mm.
 © Copyright Arrow Valves Ltd 2009-2019



Q:\Arrow Valves\Products\SP Standpipes\spstdatasheet.docx 09-Jan-19

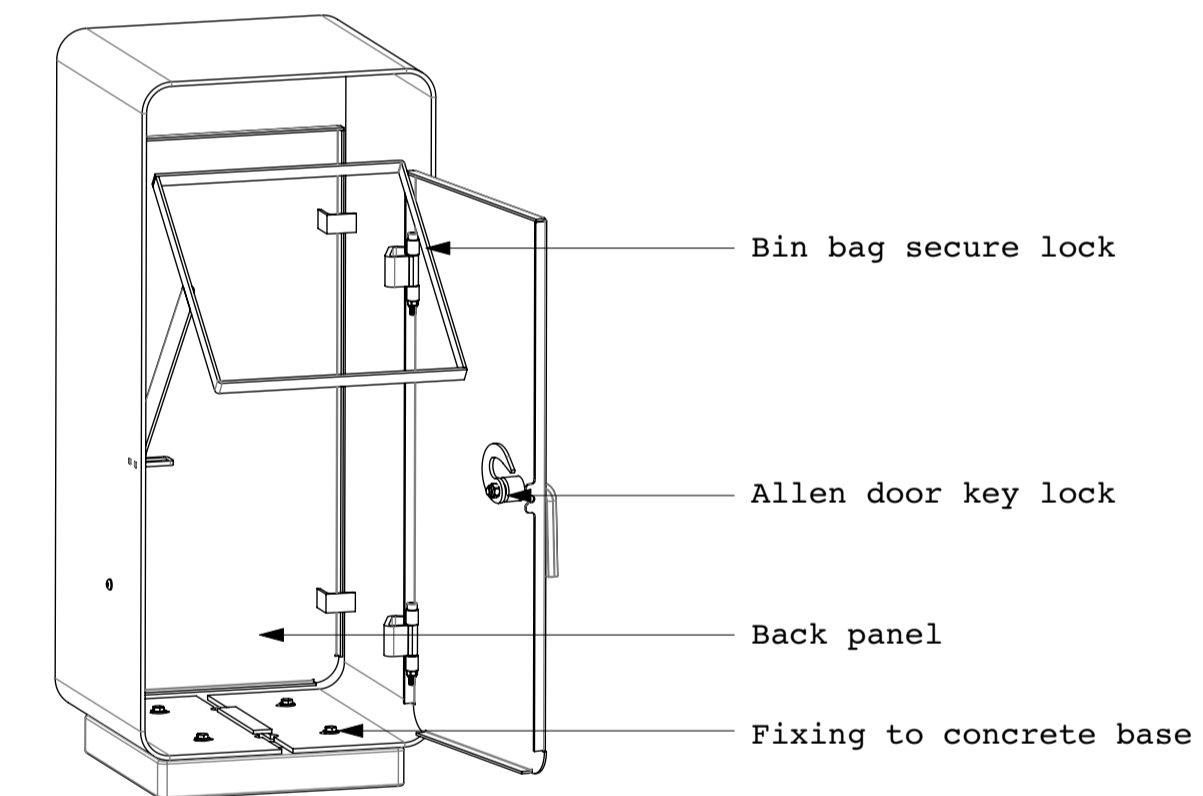
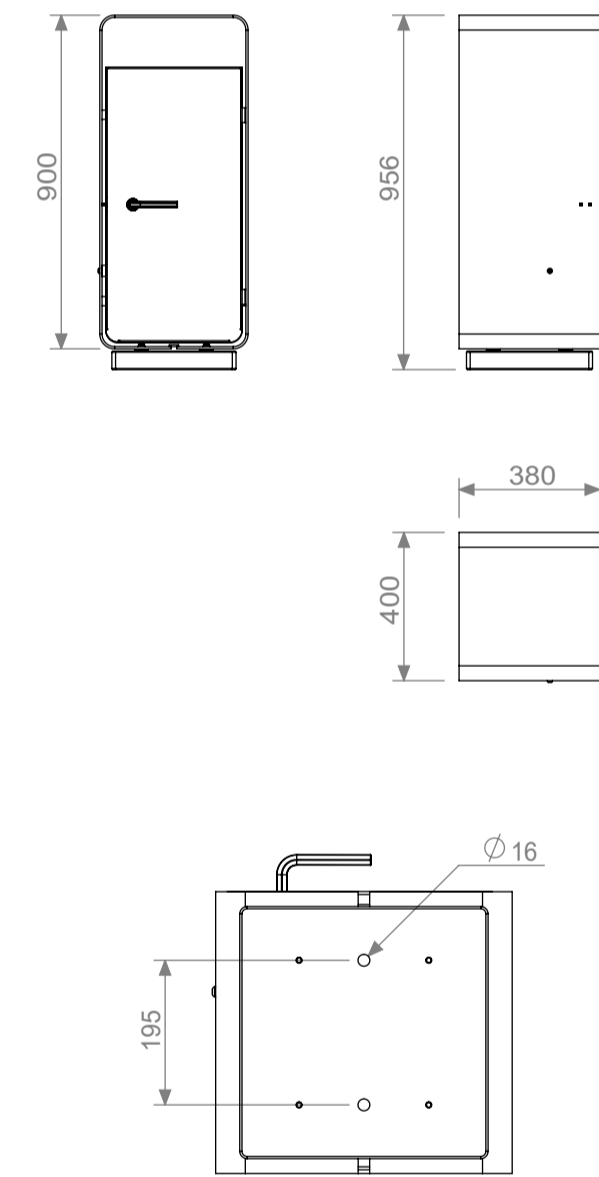

Key:

Rev	Date	Description
30.10.20	T1	Issued for Tender

JCLA Jonathan Cook Landscape Architects Ltd 3A Iliffe Yard LONDON SE17 3QA Tel +44 (0)207 703 3270 www.jcla.co.uk	
Client	W.RE
Project	SP108: St Pancras Commercial centre
Drawing Title	Landscape elements: Cycle stands / bins / irrigation
Drawing Number	SP108-82-LE
Date	30.10.20
Revision	T1
Scale (8 A1)	1:10
Drawing Status	Stage 4