

1 Boundary Wall Typical Section- Middle part between gates
1:10

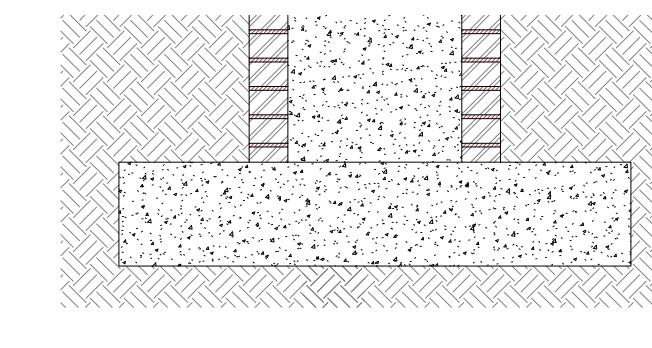

2 Gate Pier Detail Section
1:10

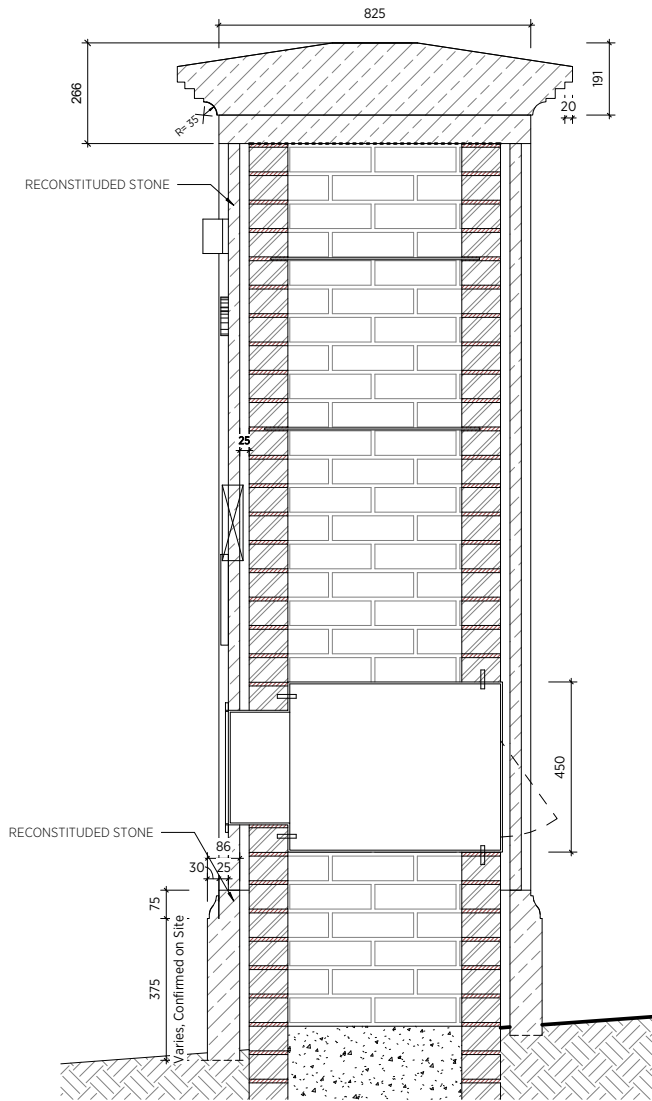
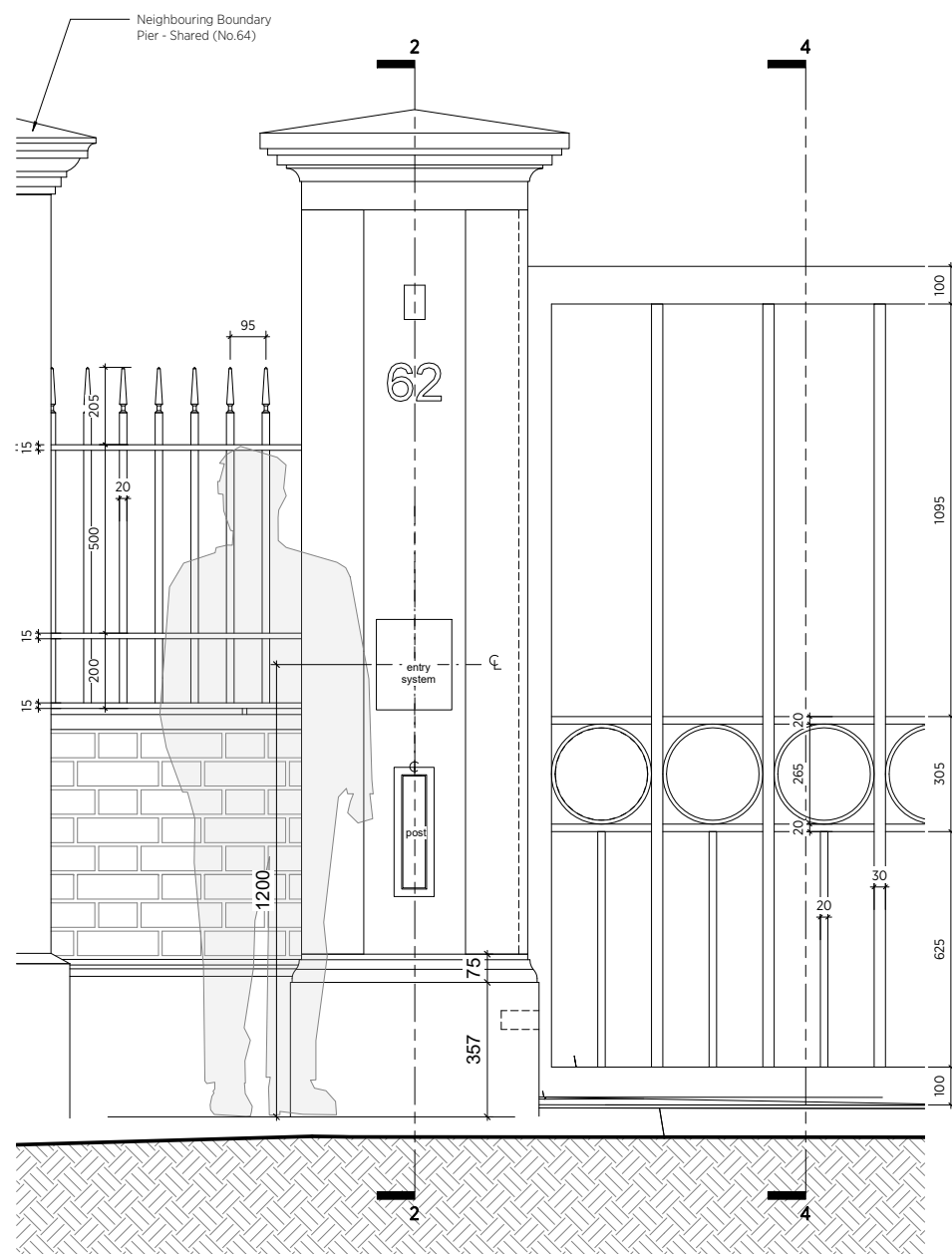

3 Gate Pier-Front Elev
1:10

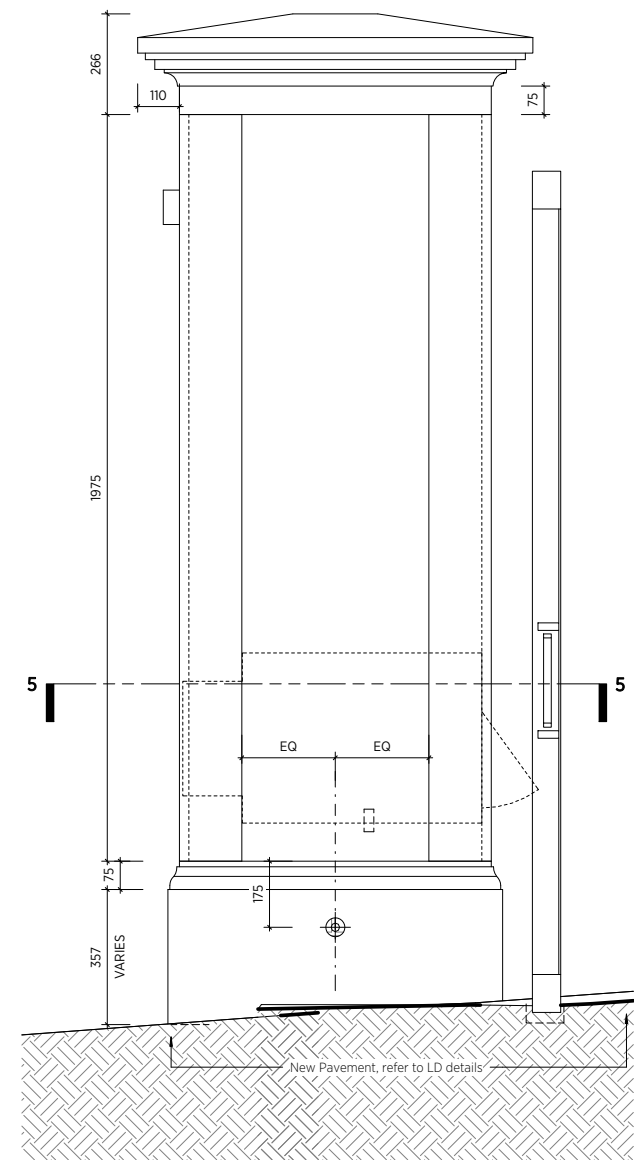

4 Gate Pier- Side Elev
1:10

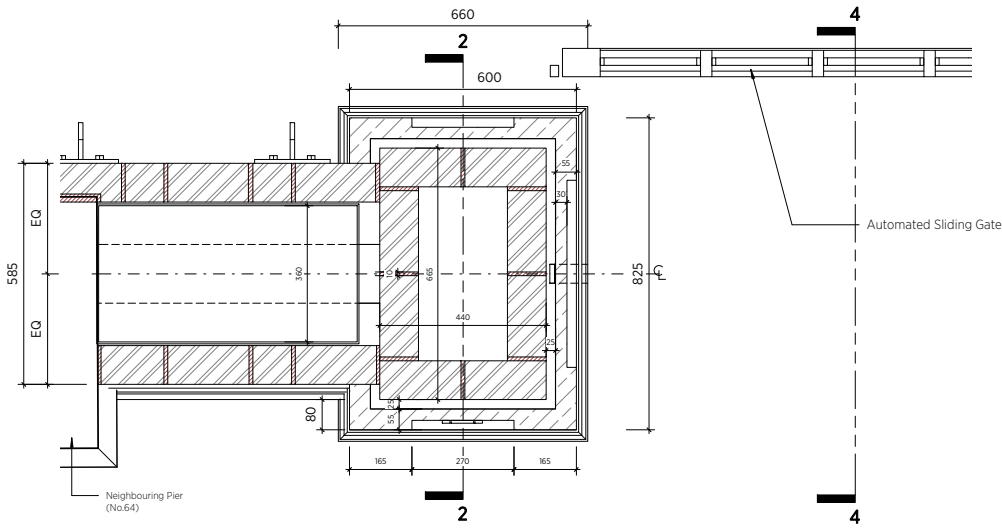

5 Gate Pier Detail-Plan
1:10

General Notes
 This drawing is copyright of KSR architects. This drawing must be read in conjunction with the Designer's Risk Assessment, specification and all other relevant documentation and drawings.
 KSR architects accept no liability for any expense, loss or damage of whatsoever nature and however arising from any variation made to this drawing or in the execution of the work to which it relates which has not been referred to them and their approval obtained.
 Areas are based on un-checked survey and are approximate only. Do not scale from this drawing or the digital data, only figured dimensions are to be used. Refer to linear scale for guidance.
 Check all dimensions on site prior to carrying out any works and advise any discrepancy.

Status: _____
 Scale: _____
 Project: **62 Avenue Road**
 Date of first issue: **12/24/21**
 Drawn By: **Author**
 Checked By: **Checker**
 Drawing No: **19021-EZR-902**
 Rev: _____
 Description: _____
 Date: _____
 © KSR Architects

KSR ARCHITECTS & INTERIOR DESIGNERS
 KSR Architects LLP
 14 Greenland Street
 London NW1 0ND
 t: +44 (0)20 7636 5000
 www.ksrarchitects.com

Front gate and boundary wall