

SECTION A-A

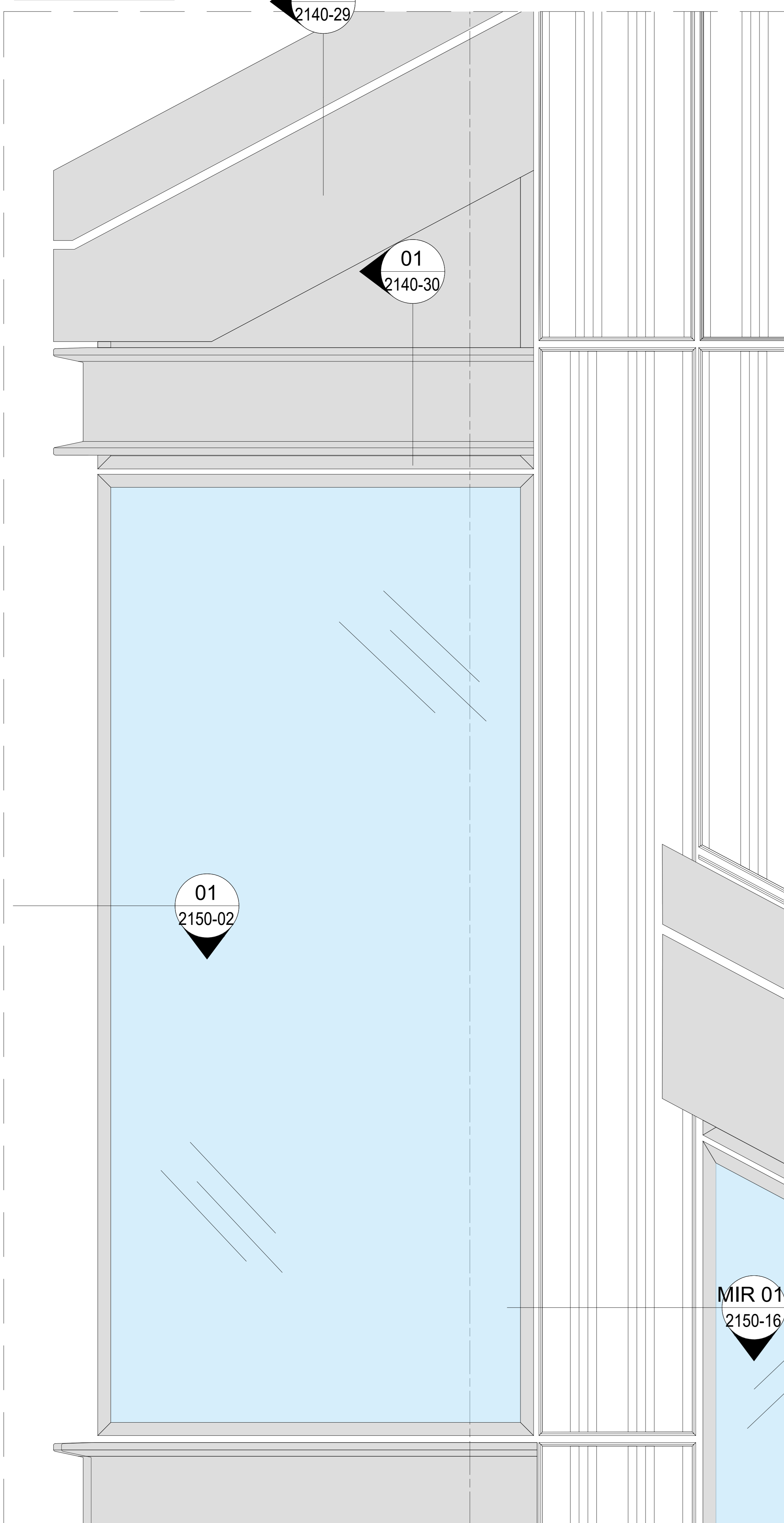

PARTIAL ELEVATION

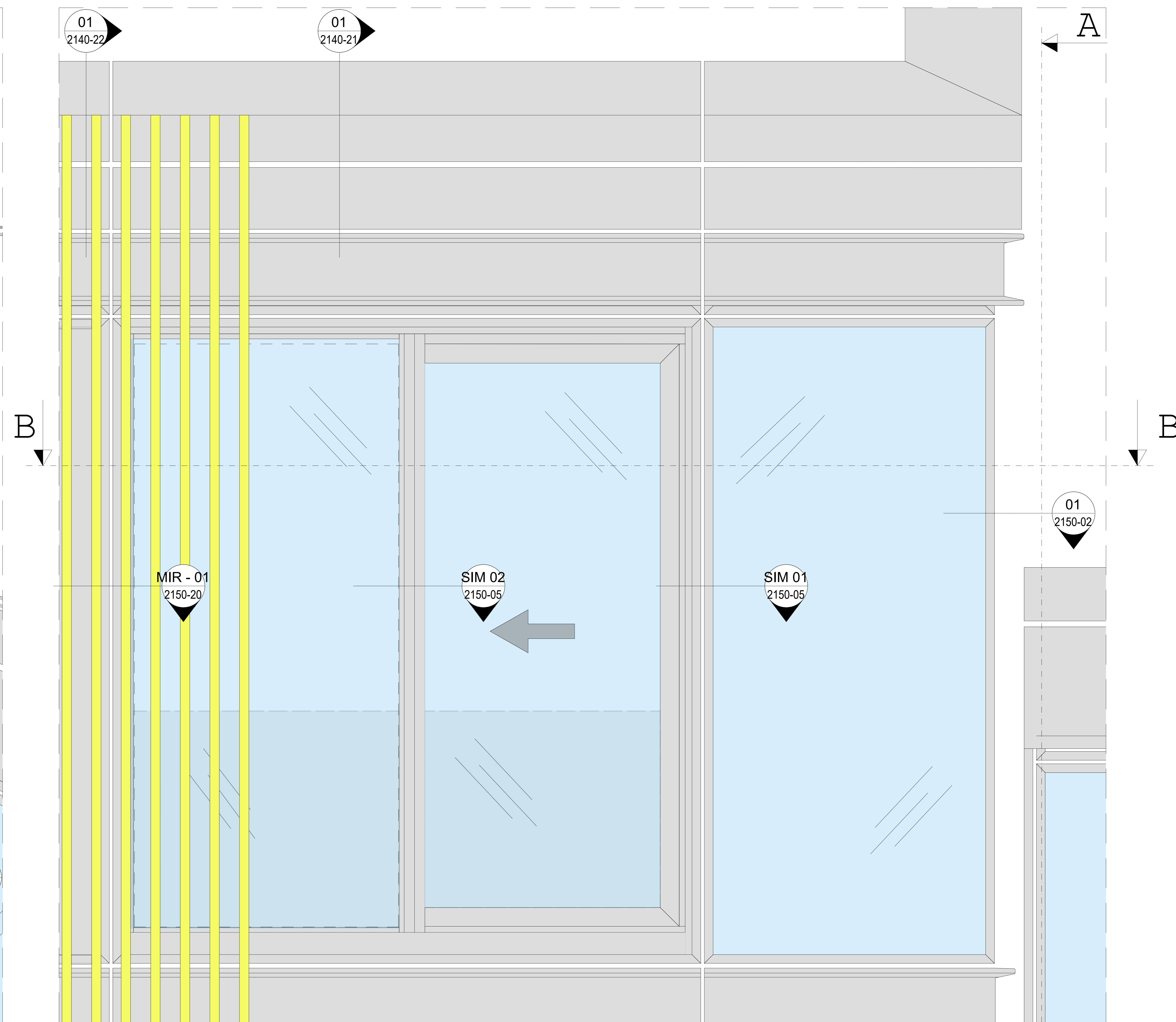

KEY PLAN

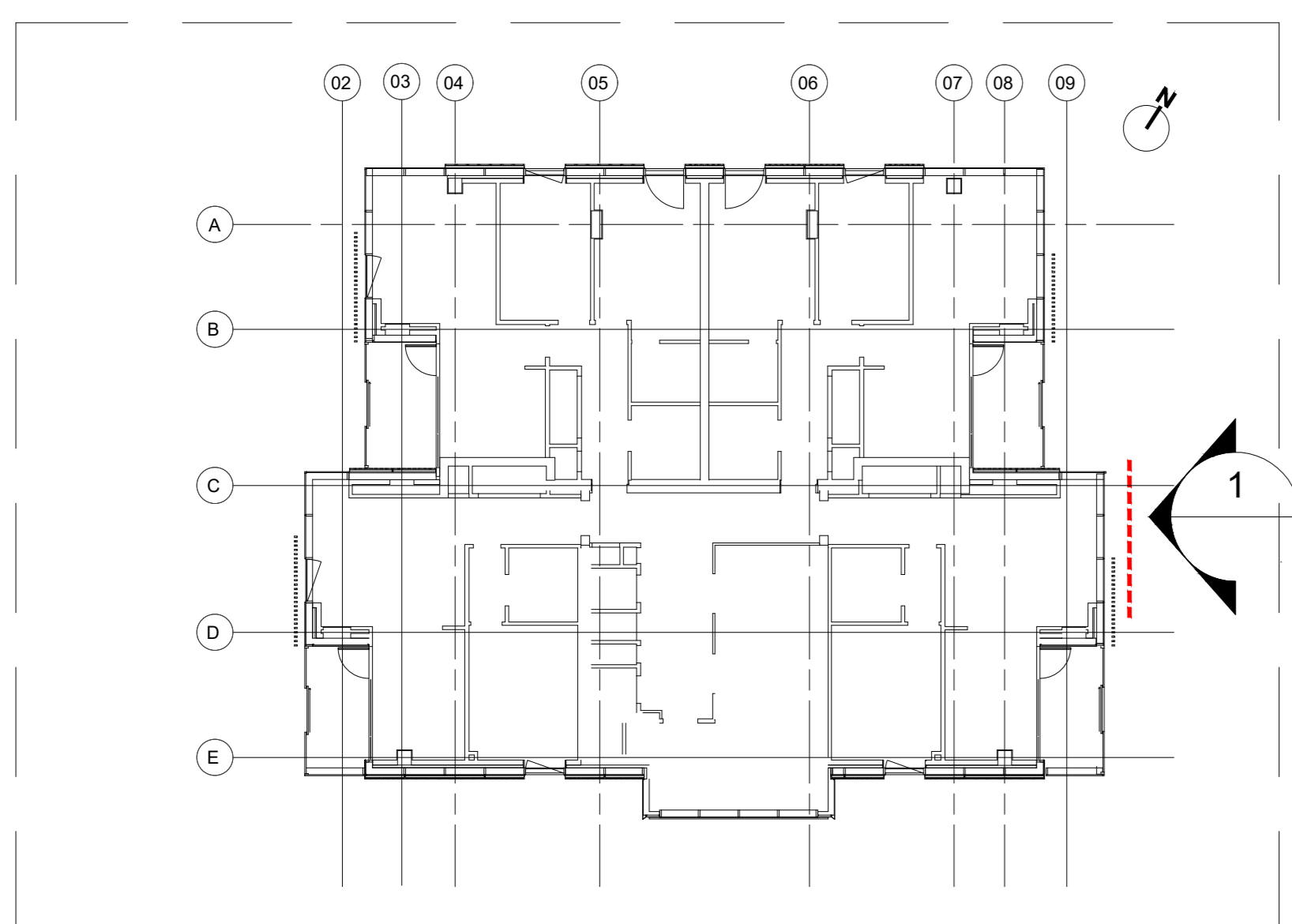

SECTION B-B

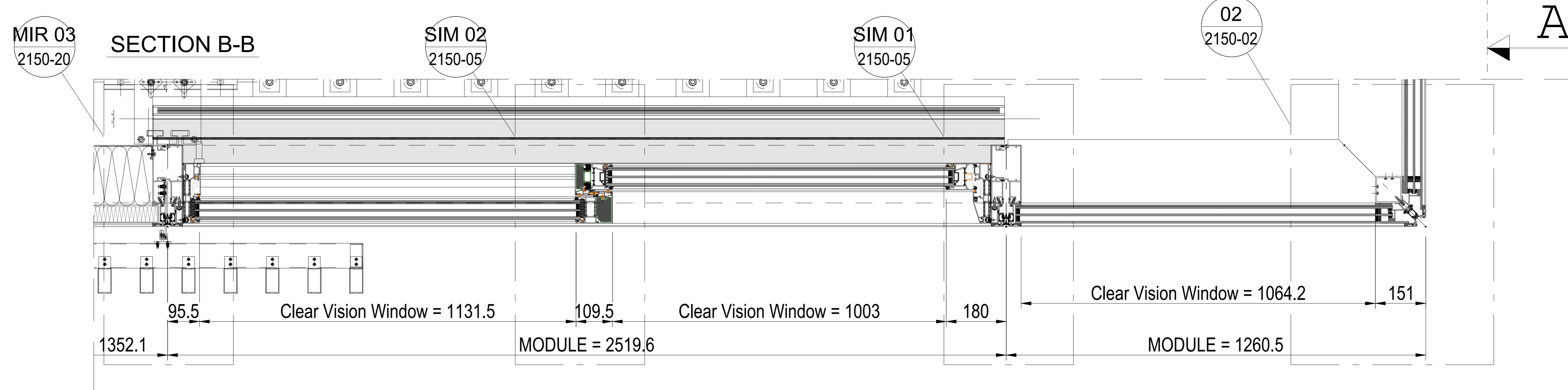

Proprietary Note:
The copyright of this drawing remains with us. No copies may be taken without our written consent nor the drawing made available to third parties. Legal action will be taken in case of breach of the above requirement.

NOTES:

Design Architect
Stiff + Trevillon Architects Ltd
16 Woodfield Road, London W9 2BE

Client
Henry Construction Projects Ltd
Church Rd, Cranford, Middlesex, TW5 9RY

Rev	Date	By	Description

Project name
BRILL PLACE RESIDENTIAL TOWER
Brill Place, London

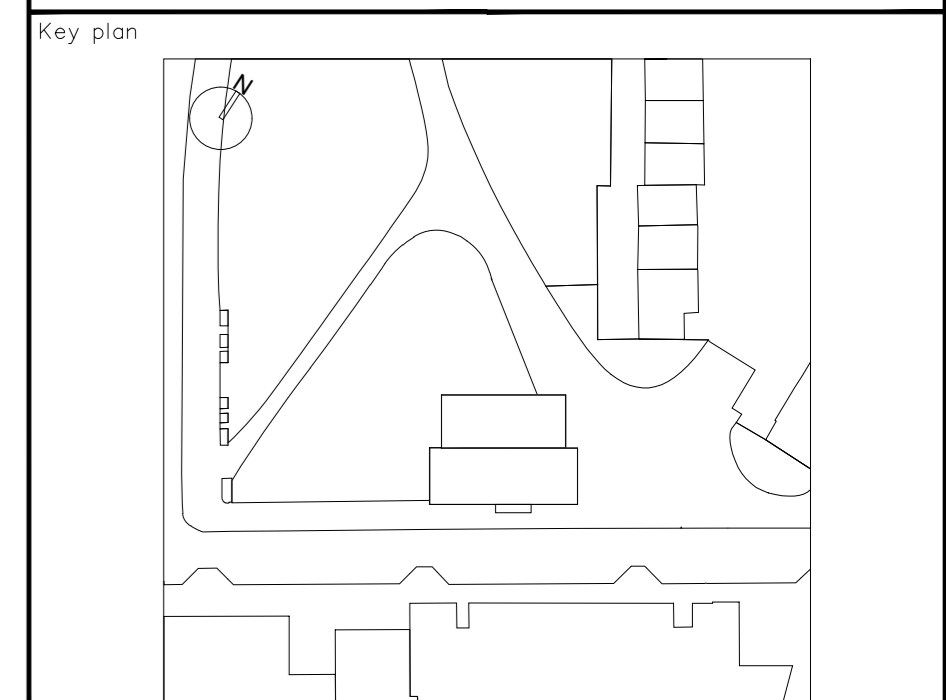

Project No. Lot No.
bluesteel
EXCELLENCE FOR ARCHITECTURE
Via Vittorio Veneto, 15 - 31014 San Martino di Cole Umberto (TV) Italy
Phone: 0438-520113 - Fax: 0438-520498

Title
Unitized System Facade
EWS01 - Partial Elevations
WinterGarden @ East Lvl 19

Drawn by: **D. Da Re** Checked by: **D. Da Re** Approved by: **L. De Noni**
Scale (A0 size): First date of issue: **20.04.2021**

Status: Drawing No.: **0182-2125-25** Revision No.: **00**
DIVULGATION AND REPRODUCTION FORBIDDEN BY LAW