

TYPE 1 MANHOLE - SECTION

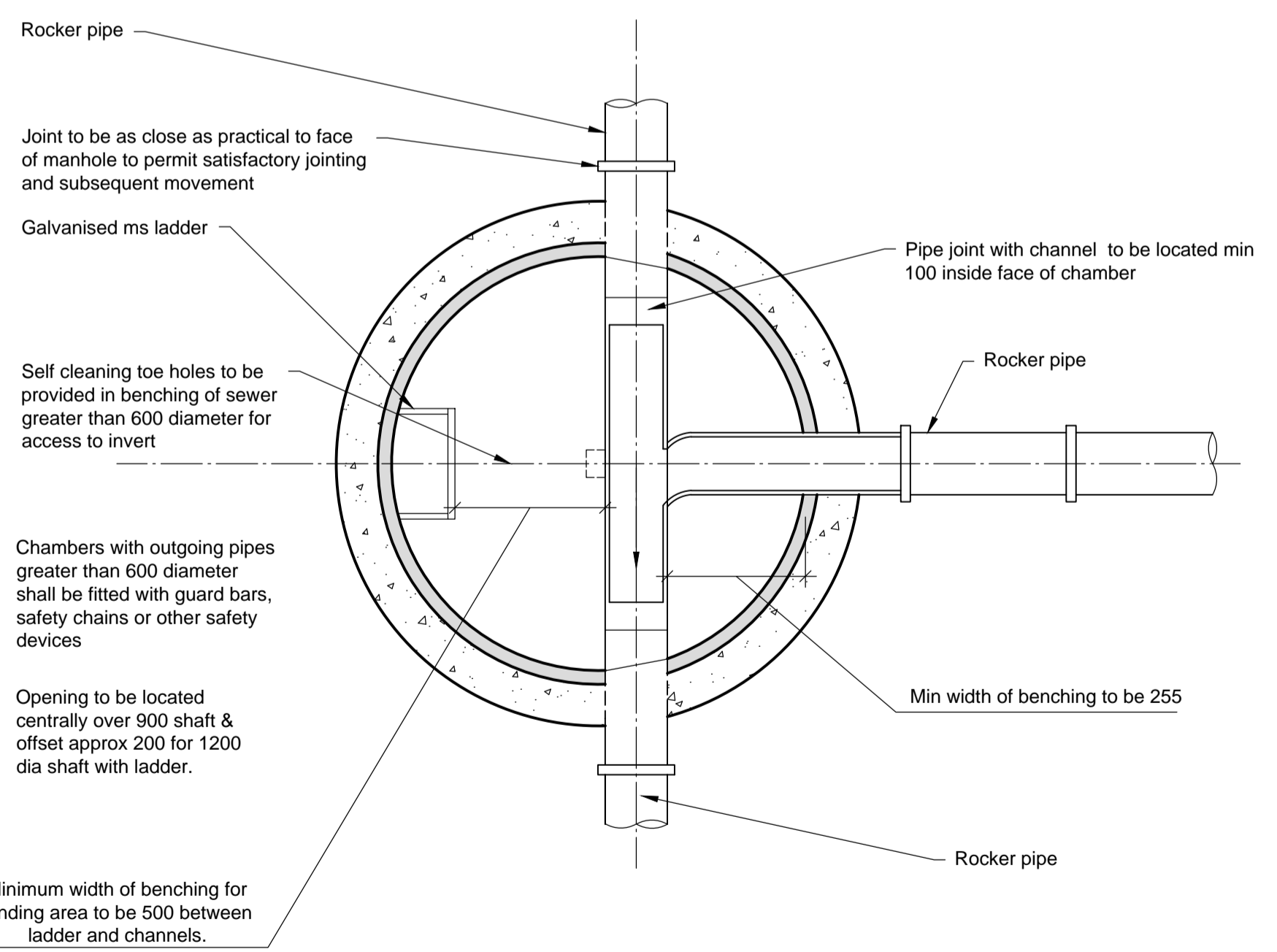

TYPE 1 MANHOLE - PLAN
DEPTH TO SOFFIT: 3.0m to 6.0m

TYPICAL DETAIL. SEE SCHEDULE FOR DIMENSIONS AND GA FOR NUMBER OF CONNECTING PIPES.

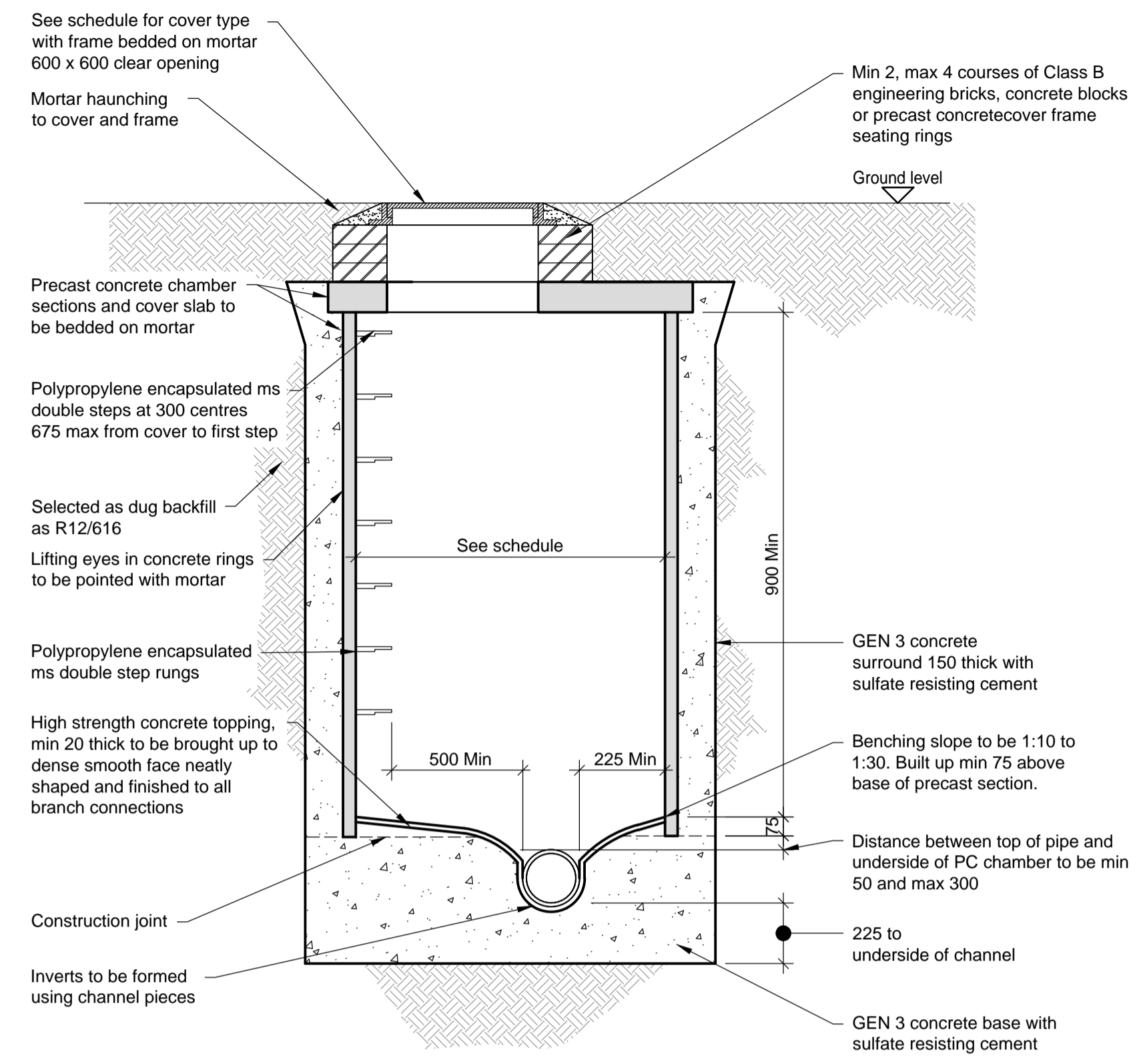

TYPE 2 MANHOLE - SECTION

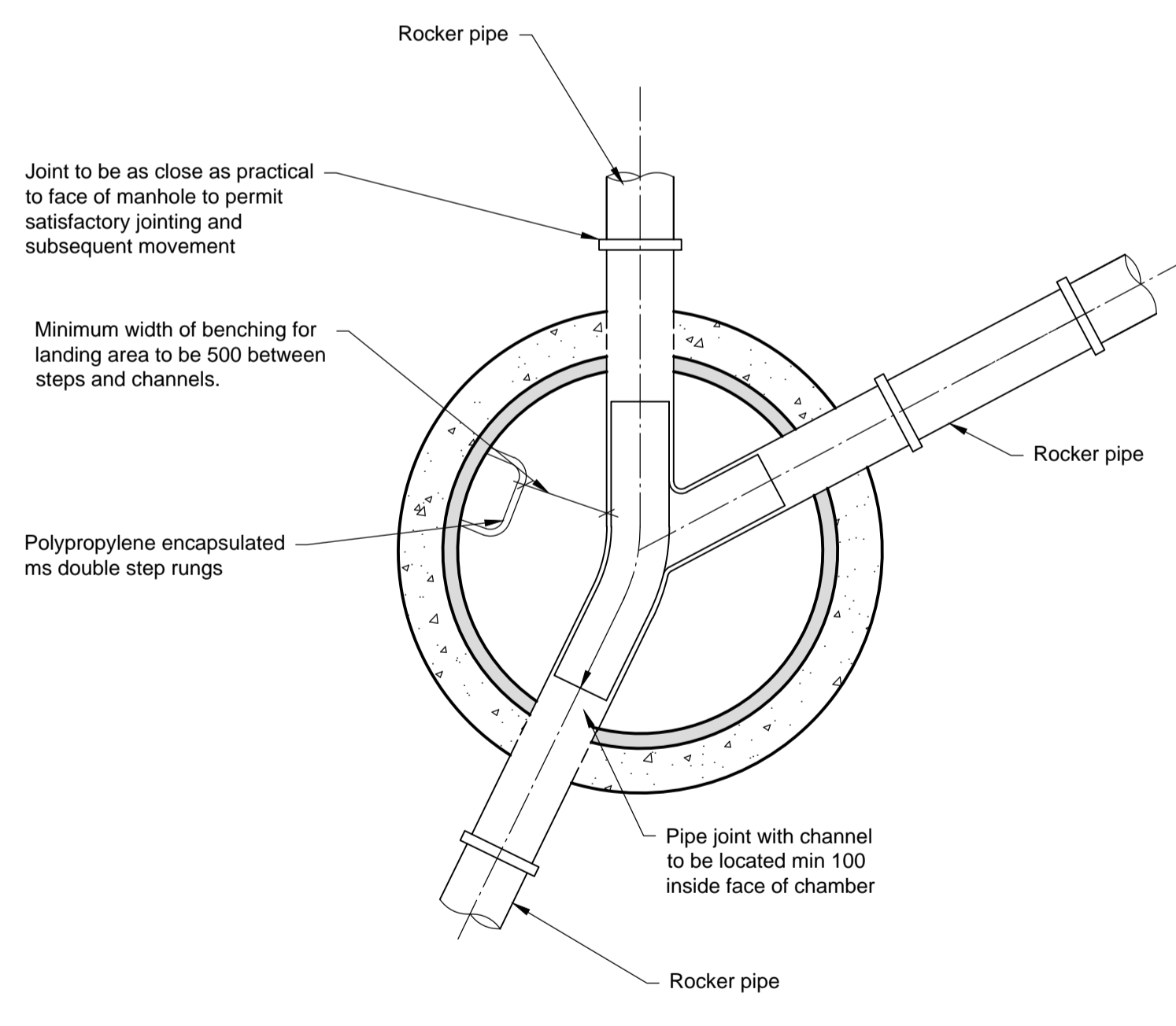

TYPE 2 MANHOLE - PLAN

DEPTH TO SOFFIT: 1.35m to 3.0m
TYPICAL DETAIL. SEE SCHEDULE FOR DIMENSIONS AND GA FOR NUMBER OF CONNECTING PIPES.

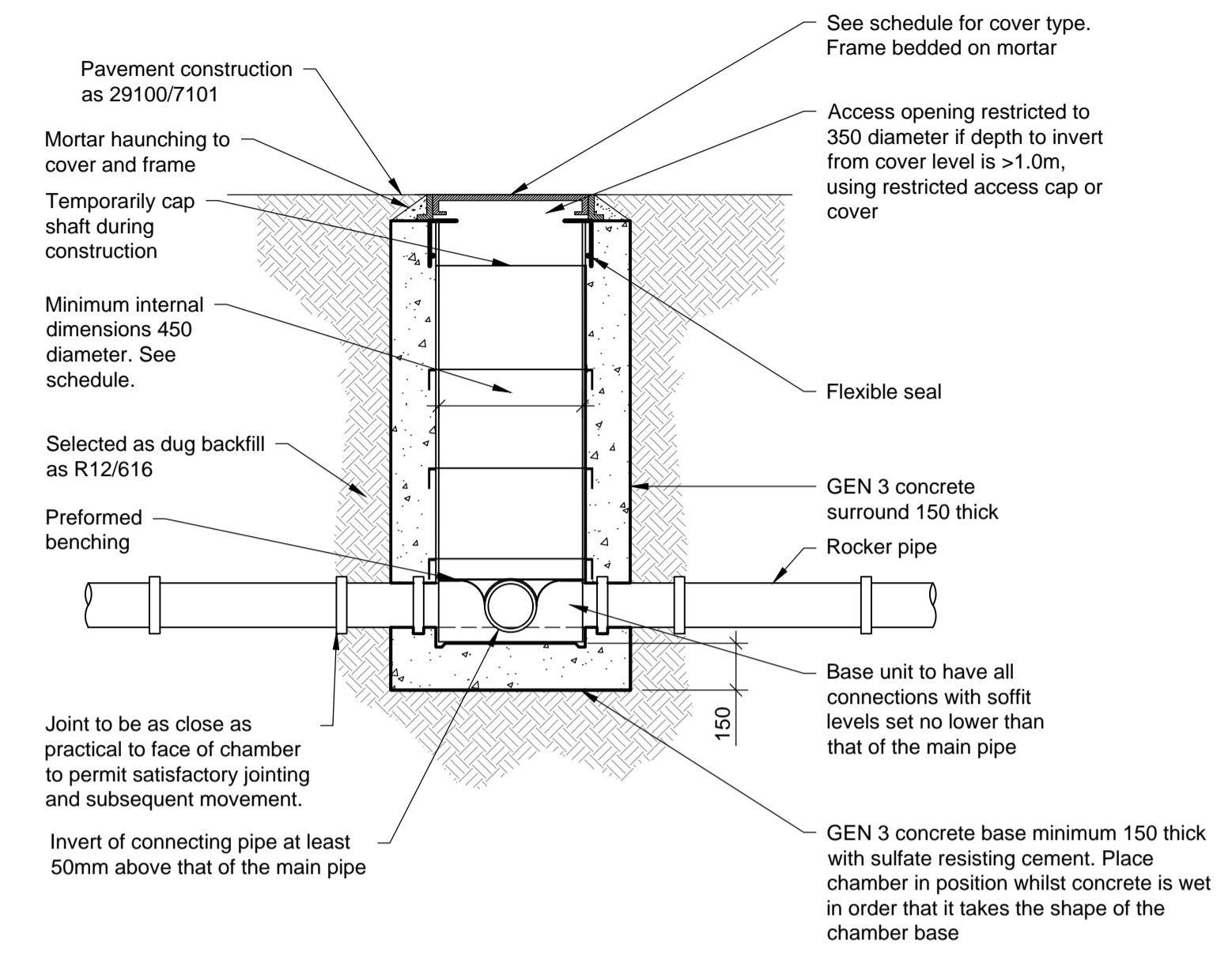

TYPE 3 PLASTIC INSPECTION CHAMBER

FOR 450 DIAMETER CHAMBERS IN :-
• SOFT LANDSCAPING, PEDESTRIAN (A15) AREAS UP TO 3.0m DEEP
• DOMESTIC DRIVEWAYS (B125) AREAS UP TO 1.0m DEEP

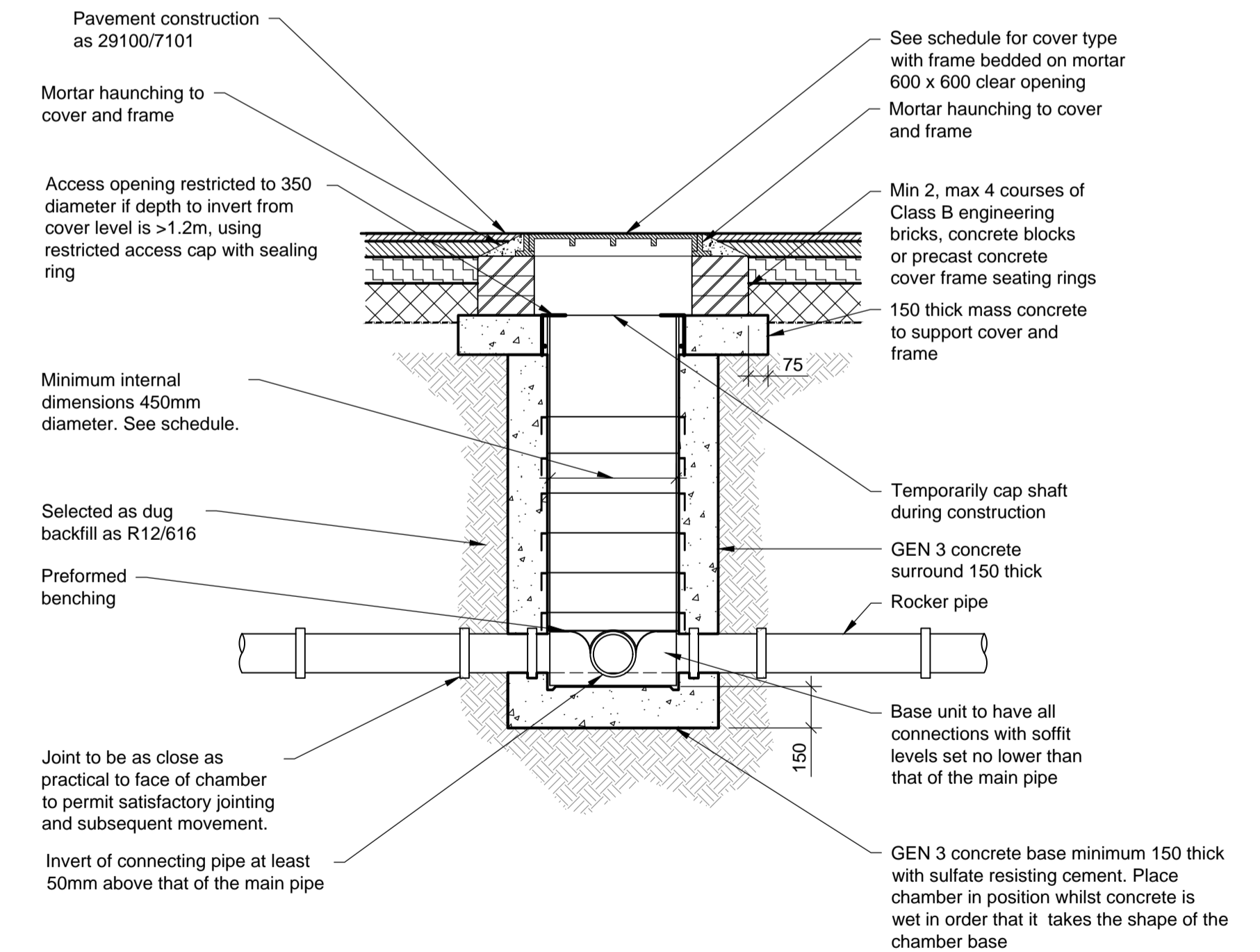

TYPE 3 PLASTIC INSPECTION CHAMBER

FOR 450 DIAMETER CHAMBERS IN :-
• DOMESTIC DRIVEWAYS (B125) AREAS FROM TO 1.0m TO 3.0m DEEP
• AREAS SUBJECT TO VEHICLE LOADING (D400) UP TO 3.0m Deep

- NOTES :
1. This drawing is to be read in conjunction with all relevant Architect's, Engineer's and specialists' drawings and specifications.
 2. Do not scale from this drawing in either paper or digital form. Use written dimensions only. To check that this drawing has been printed to the intended scale this bar should be 50mm long @ A1 or 25mm long @ A3.
 3. Health & Safety : All specific drawing notes are to be read in conjunction with the project "Information Pack" and "Site Rules".
 4. For general notes refer to Drawing No. 29100 / 0002.

Rev	Date	Drawn	Eng	Amendment
P03	28.10.21	TP	KB	Issued for Stage 3
P02	22.10.21	TP	KB	Contract Issue
P01	16.02.21	AC	KB	Issued for Information

LIDDELL ROAD - PHASE 2
BELOW GROUND DRAINAGE DETAILS SHEET 1

Status
STAGE 3 ISSUE
NOT FOR CONSTRUCTION

Drawn	AH	Eng	KB
Scales	1:20 at A1	1:40 at A3	
Drawing No	Rev		
	29100 / 6101	P03	
Doc Ref.	29100-PAM-ZZ-XX-DR-C-6101		