

Horizontal section through window

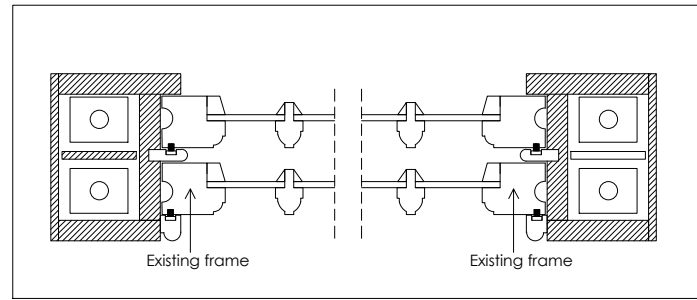

Typical plan view details

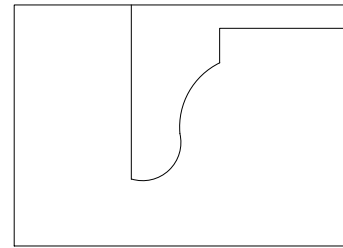

Horn design

Vertical section through window

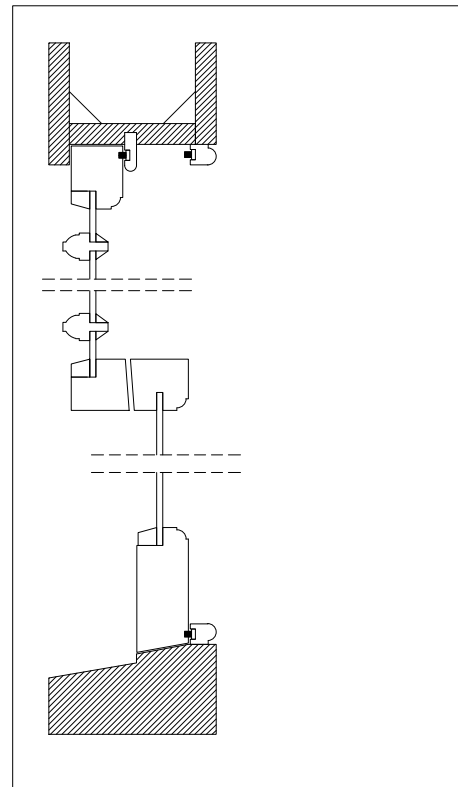

Typical section details

Existing window Details  
Scale 1:5

Vertical section through window

Horizontal section through window

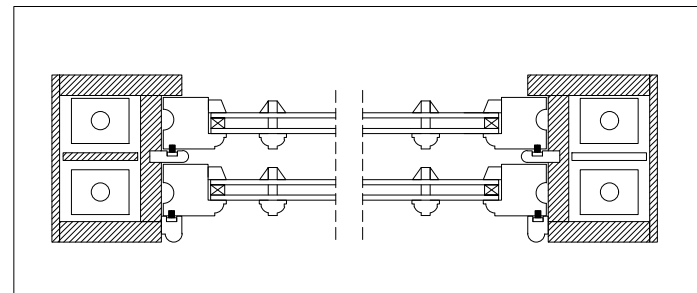

Typical plan view details

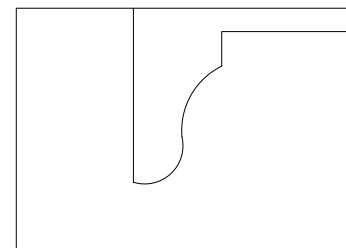

Horn design

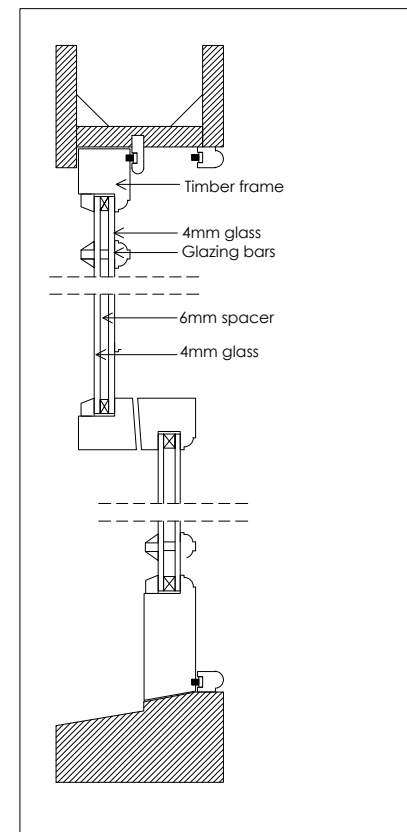

Typical section details

W4-Proposed double glazed sash window Details  
Scale 1:5

PLANNING DRAWINGS ONLY.  
NOT FOR CONSTRUCTION

ALL DIMENSIONS AND INFORMATION ON THE DOCUMENT MUST THEREFORE BE CHECKED ON SITE FOR ACCURACY AND APPROVED WITH THE BUILDING INSPECTOR PRIOR TO THE COMMENCEMENT OF WORKS.

CONTRACTORS MUST VERIFY ALL DIMENSIONS, LEVELS AND BOUNDARIES ON SITE BEFORE COMMENCING ANY WORKS.

ALL EXISTING LINTELS, BEAMS, FOUNDATIONS ETC. TAKING ANY NEW LOADS ARE TO BE EXPOSED AND RE-ASSESSED FOR THE NEW LOAD AND TO BE RE-INFORCED OR REPLACED AS NECESSARY AT THE DISCRETION OF THE LOCAL AUTHORITY.

ALL STRUCTURAL INFORMATION SHOULD BE CHECKED AGAINST DETAILED STRUCTURAL ENGINEERS INFORMATION AND CALCULATION SHEETS.

REFER STRUCTURAL ENGINEER'S DRAWINGS FOR STRUCTURAL DETAILS

CONTRACTOR TO CHECK EXISTING HEIGHTS PRIOR TO CONSTRUCTION

This drawing must be read in conjunction with all other relevant documentation and drawings. No liability will be accepted for any expense, loss or damage of whatsoever nature and however arising from any variation made to this drawing or in the execution of the work to which it relates which has not been referred to them and their approval obtained.



Drawing issued for  
Planning

Project  
Second Floor Flat, 128A Regents Park Road, London, NW1 8XL

Client  
-

Title  
EXISTING AND PROPOSED DETAIL

Date  
13/01/2022

Scale @ A3  
1:5

REV  
-

Drawing No-Revision:  
E104

