

PLAN 1 - COUNTER LEVEL

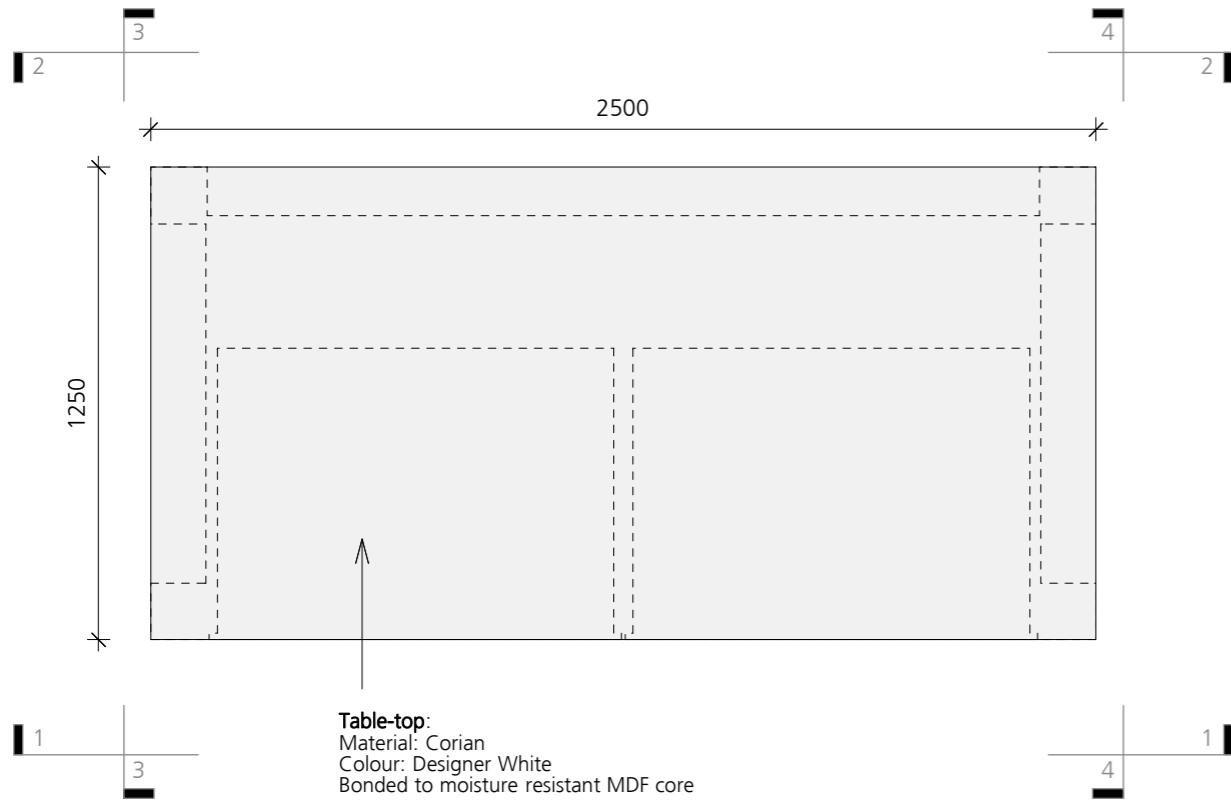

ELEVATION 1

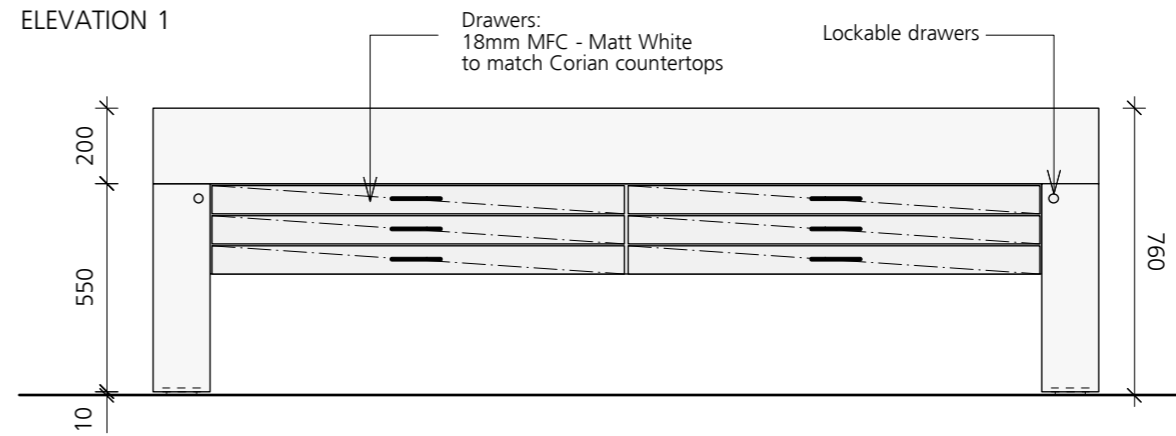

ELEVATION 2

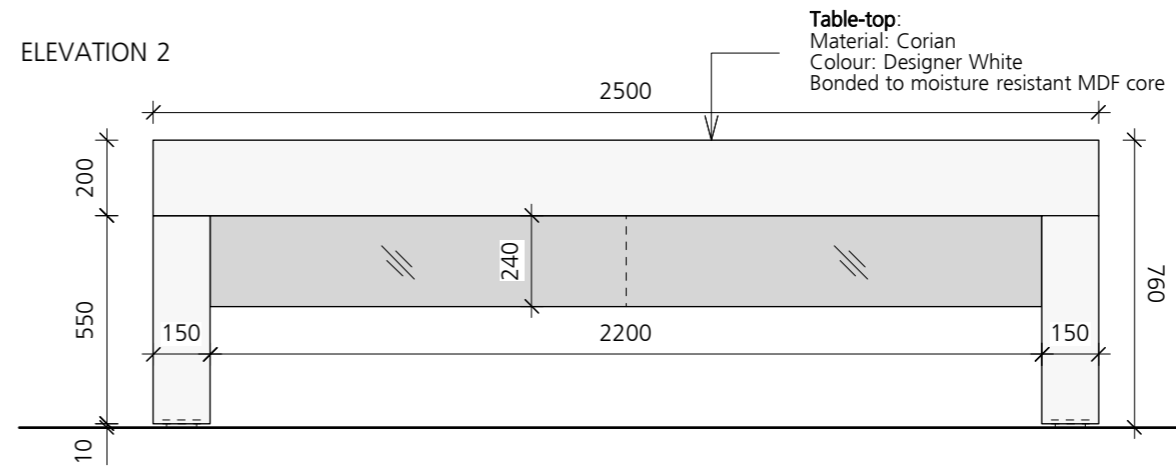

PLAN 2 - BELOW COUNTER LEVEL

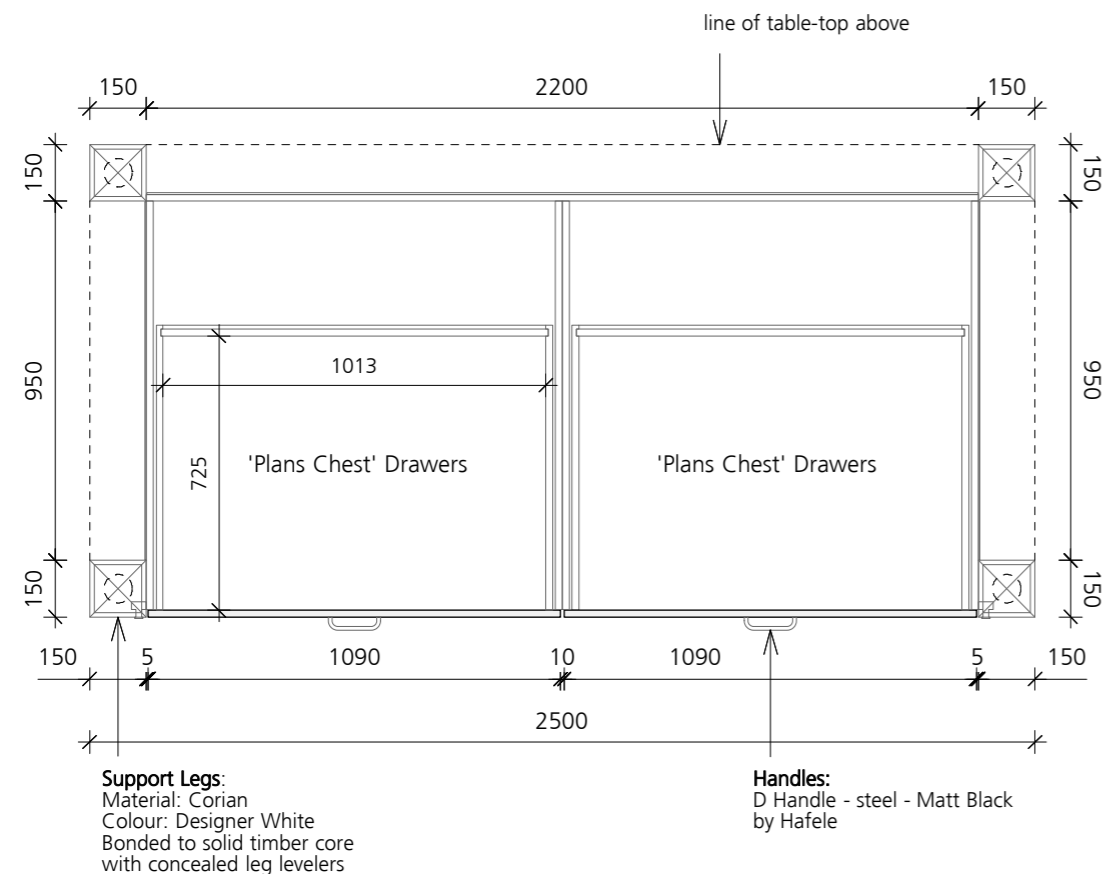

ELEVATION 3

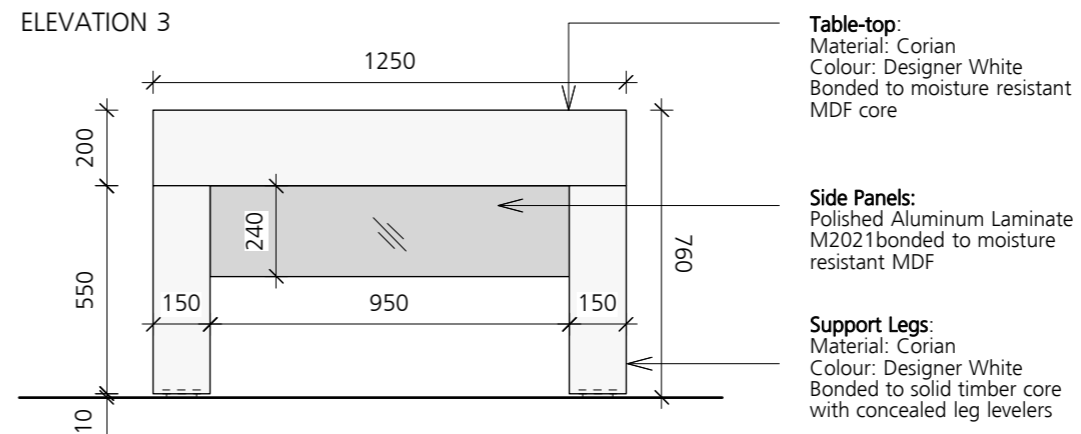

ELEVATION 4

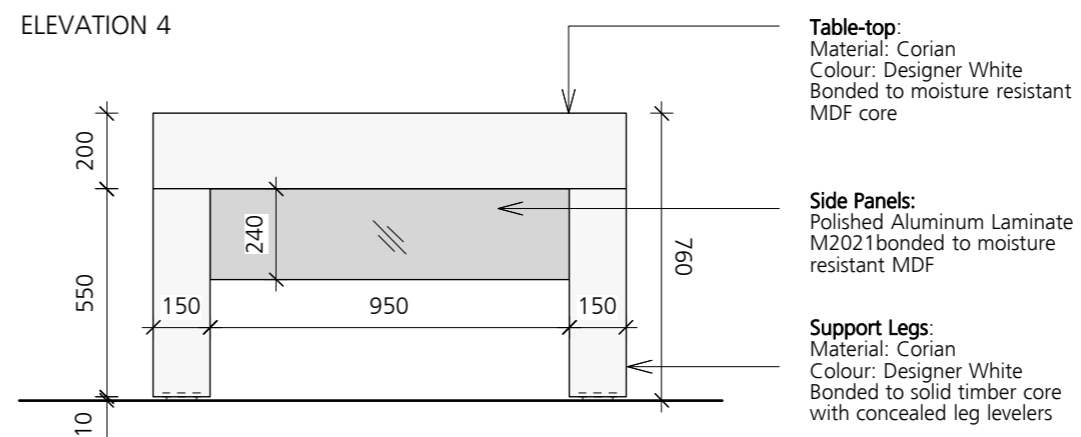

NOTES

All dimensions are from structure to structure unless indicated otherwise.

Elements of structure and services are indicated for coordination purposes only. For full structural and services layouts refer to Structural and Services Engineers' drawings.

Do not scale directly from the drawing. All dimensions to be checked on site prior to construction or fabrication of any elements.

Any discrepancies between figured dimensions to be reported to the architect for clarification prior to commencing work.

For legend see signature sheet 112_C02B_001.

© Copyright Reserved

Rev	Date	Comments
-	-	-

TONY FRETTON ARCHITECTS

Tony Fretton Architects Ltd
Highgate Studios, 53-79 Highgate Road, London NW5 1TL
T+44 (0)20 7284 2000, F+44 (0)70 1197 5379
mail@tonyfretton.com, www.tonyfretton.com

Job No:	298
Project:	Camden Art Centre - Bookshop
Drawing title:	Display Table Plans & Elevations
Scale:	1:20 @ A3
Origination Date:	Jan, 2022
Status:	Planning

Drawing No:	298_4_702	Rev	-
-------------	-----------	-----	---