

Proposed Detail 1 @ 1 : 10

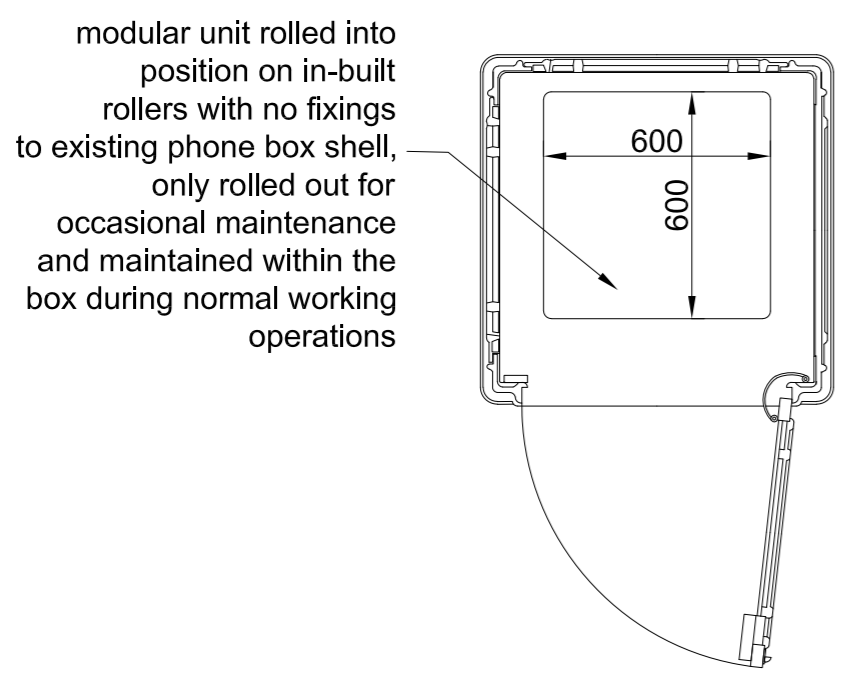

Proposed Plan @ 1 : 20

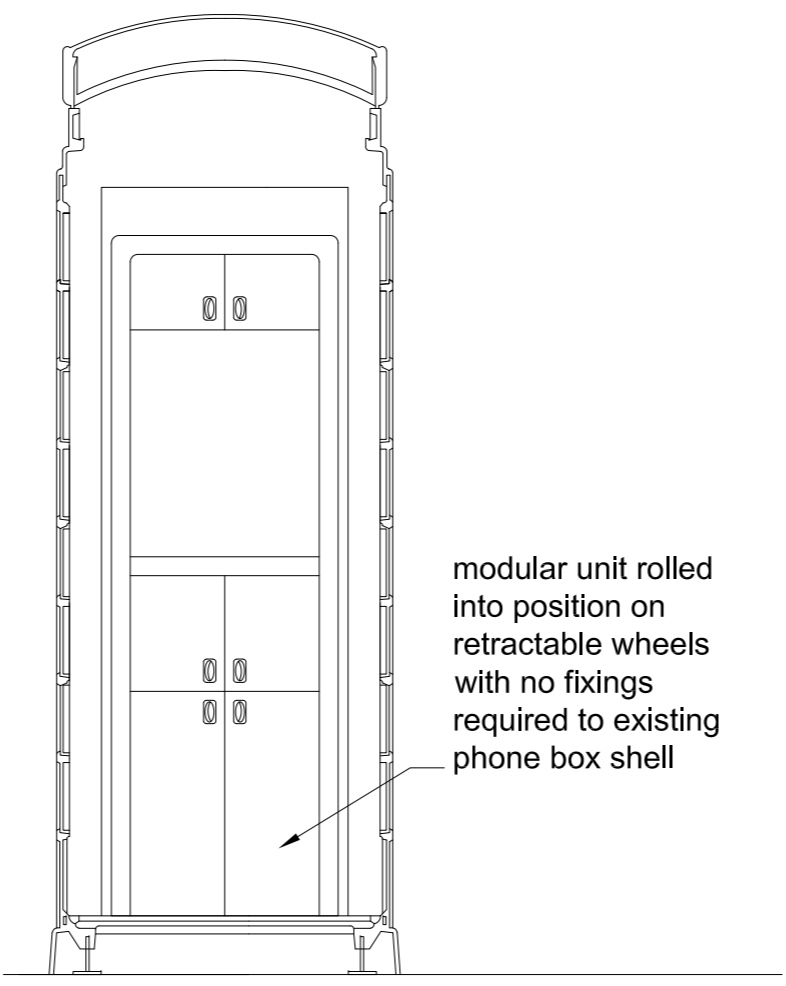
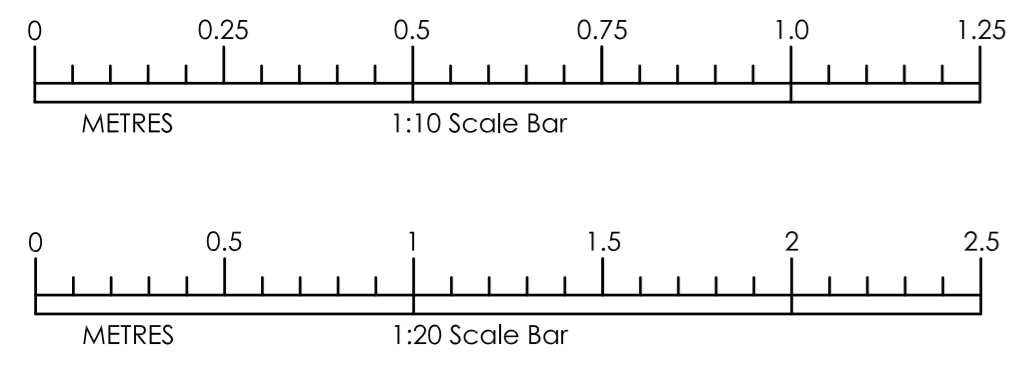

Proposed Section @ 1 : 20 Showing Retail Unit

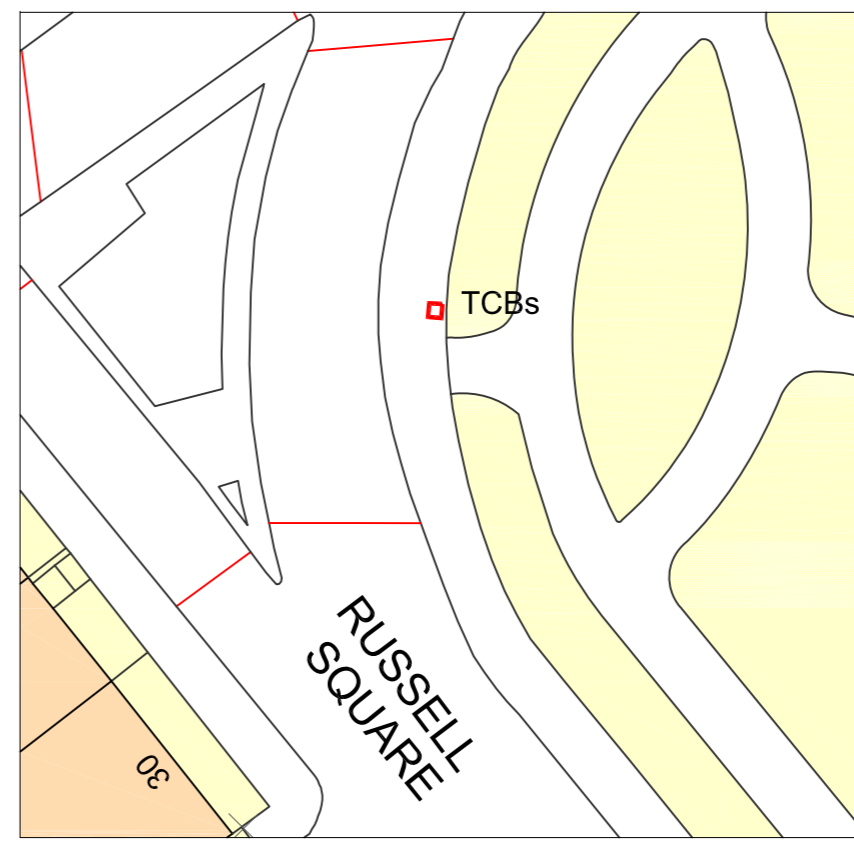
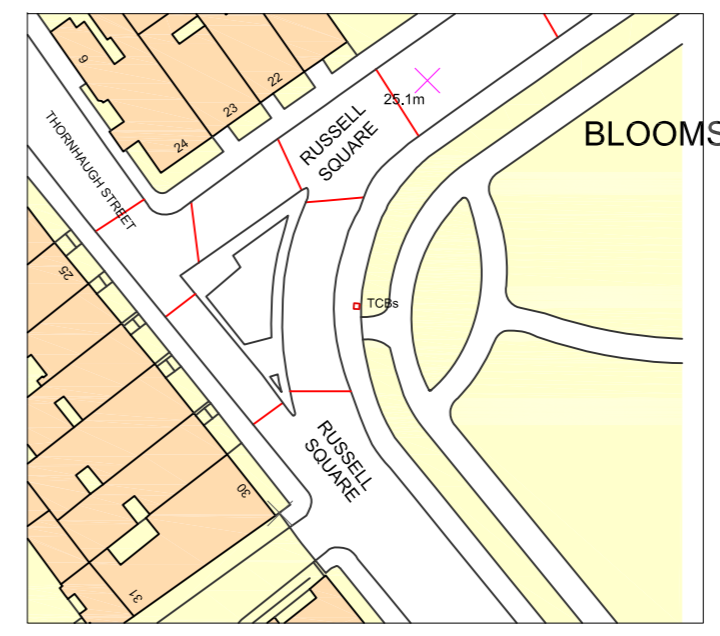

Block Plan 1:500

This drawing is copyright and may not be copied or reproduced without the written consent of this practice

The contractor is responsible for setting out and must check all levels and dimensions prior to work being put in hand

This drawing should not be scaled. Only written dimensions are to be taken in respect of this project

The Architect is to be immediately notified of any suspect omissions or discrepancies

REV	DATE	COMMENT	REV BY
-----	------	---------	--------

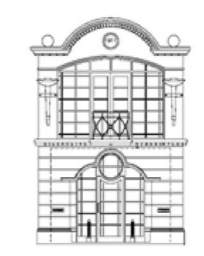

**BROE & CO. LLP**  
 CHARTERED ARCHITECTS AND PLANNING CONSULTANTS

The Studios  
 66 Haven Way, Newhaven  
 East Sussex, BN9 9TD  
 Telephone: 01273 880677  
 www.broeandco.co.uk

CLIENT **GOODIE GOODIE LTD**

PROJECT **CHANGE OF USE FROM 1NO. PHONE BOX TO 1NO. RETAIL KIOSK @ OPPOSITE "THE WIENER LIBRARY", 29 RUSSELL SQUARE, LONDON, WC1B 5DP**

DRAWING **PROPOSED PLANS, ELEVATIONS & SECTIONS AND EXISTING BLOCK & LOCATION PLANS - K6 KIOSK**

scale	date	drawn
1:20, 1:500 1:1250 @ A2	Nov 2021	FMB
job no	drawing no	revision
9274	PL01	.