

Planning Department
London Borough of Camden
5 Pancras Square
London
N1C 4AG

16 December 2021

Our Ref: 5849HER

Dear Sir/Madam

Minor Material Amendment for 'Variation of Condition 3 of 2021/2891/P' and Associated Listed Building Consent at St Andrew's House, 140 Saffron Hill, Holborn, EC1N 8QN.

These Minor Material Amendment and Listed Building Consent applications, at the above address, are submitted on behalf of our client, Anglo American Services (UK) Limited.

The tweaked proposals seek permission to insert padstones into the hidden brickwork beneath the roof. Previously the proposals showed resin rods as the connection into the brickwork. The proposed padstones are shown below.

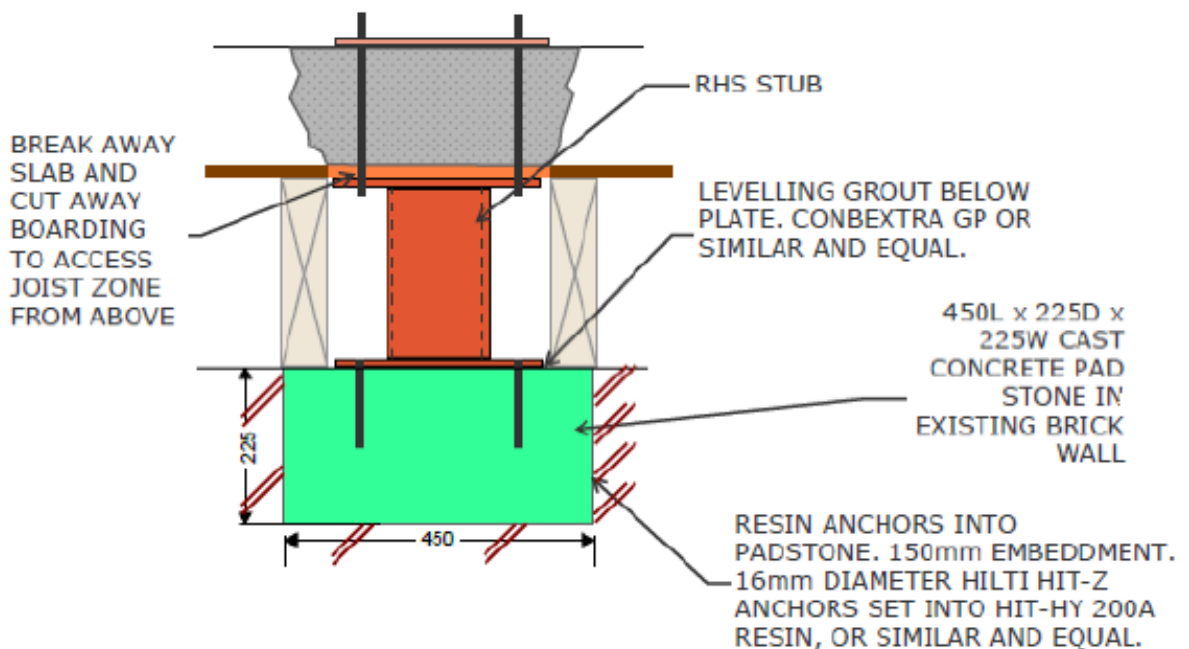

The works will ensure structural safety and will not affect any visible fabric. The proposals will allow the 2021/2891/P and 2021/3116/L approvals to be realised and the energy performance of the building to be significantly improved. For clarity, none of the approved drawings under those applications require revision and it is only the following documents that have been updated:

- Outline schedule of works dated 21/05/2021 (now dated 16/12/2021)
- Design and Access Statement dated 10/06/2021 (now dated 16/12/2021)
- Planning structural report dated 07/06/2021 (now dated 16/12/2021)

It is requested that Condition 3 of 2021/2891/P is updated accordingly.

The application fee of £234 plus a £28 Planning Portal fee has been paid.

I trust that the above information is sufficient for the determination of these applications and I look forward to receiving confirmation that the applications have been validated in due course. If in the meantime you have any queries, please do not hesitate to contact me.

Yours sincerely,

Niall Hanrahan BA (Hons) Mplan MSc (Historic Conservation) MRTPI

Associate

Planning and Heritage

Heritage Potential

London