

**ALAN J. ENGLE Y  
AND ASSOCIATES**  
Guidott House, 205 Bailbrook Lane,  
Bath, BA1 7AB  
Tel: 01225 851200  
email: alan@engleytrees.co.uk

Site: 93 Redington Road NW3 7RR (Ref AJE/AF 29132) 1-200@A2  
Drawing: Tree Protection Plan & Tree Constraints Plan & Tree Planting Locations Nov 2021

**Key:**

- Category A (Green circle)
- Category B (Blue circle)
- Category C (Grey circle)
- Category U (Red circle)
- Tree Protection Fencing (Pink line)
- Temporary Ground Protection (Light blue area)
- Crown Spread (Colour matches category)
- Tree Number
- Height
- Tree Proposed for Removal (Red dashed circle)
- Proposed Planting (Green circle with dot)

NOTE: tree/group numbers marked with an \* have approximate locations.



Figure 2 Default specification for protective barrier

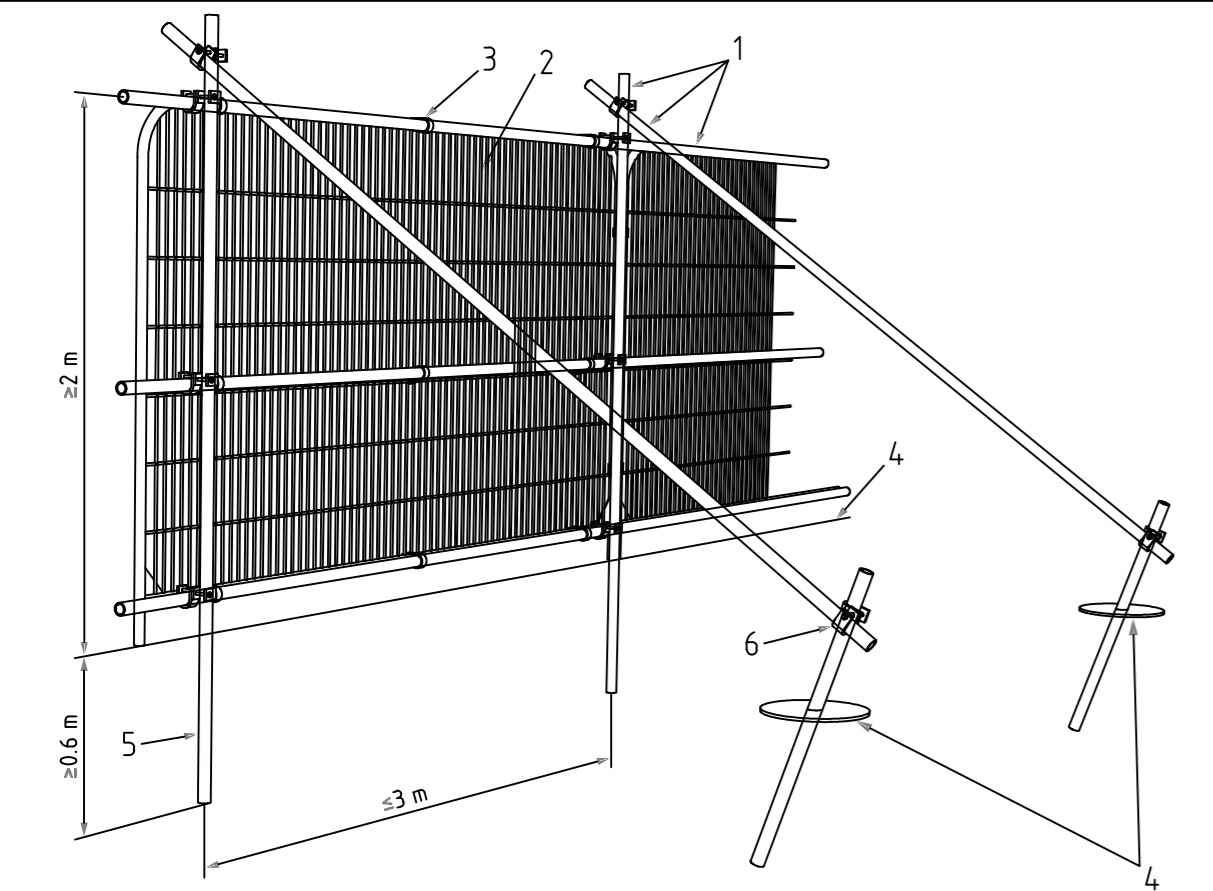

- Key**
- Standard scaffold poles
  - Heavy gauge 2 m tall galvanized tube and welded mesh infill panels
  - Panels secured to uprights and cross-members with wire ties
  - Ground level
  - Uprights driven into the ground until secure (minimum depth 0.6 m)
  - Standard scaffold clamps

NOTE 1 Examples of configurations for steel mesh perimeter fencing systems are given in BS 1722-18.  
Note 2 It might be feasible on some sites to use temporary site office buildings as components of the tree protection barriers, provided these can be installed and removed without damaging the retained trees or their rooting environment.  
6.2.2.4 All-weather notices should be attached to the barrier with words such as: "CONSTRUCTION EXCLUSION ZONE - NO ACCESS"

**Tree Specification**

New Trees - Silver Birch and Small Leaved Lime - Light Standard 1.8 - 2.4m height.  
A 75mm depth of mulch to be applied to a distance of not less than 1m from the stems.  
Maintenance  
Year 1. Weed control to be by "hand weeding".  
Staking - Stake to be attached no higher than  $\frac{1}{3}$  tree height - to promote incremental growth.  
Watering - 25 litres every other week from April to September for the first 2 years and weekly during drought periods.  
Inspect stake/tie/guard replace as necessary  
Year 2 as Year 1.

**SUPPLY OF PLANTS/ TREE**

- Suppliers: Members of the Horticultural Trades Association Nursery Certification Scheme.

**TREE PIT**

- Scarify horizontal bases and vertical sides.
- Pit bottom: Pit sides: Scarify.
- Backfilling material: Good quality topsoil

The planting work should conform to the BS 8454 2014 Trees: From Nursery to Independence in the Landscape: Recommendations