

## CP03-C-0500

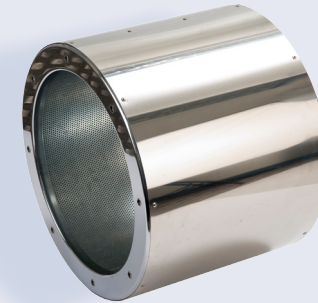

### 500 DIA FAN MOUNTED SILENCER

Available in two standard lengths C Series Silencers have excellent attenuation properties, achieved with sound absorbing infill retained in the attenuator casing by a perforated liner. The central pod (code P) is an option to increase the insertion loss, however it will add resistance.

- Fits directly onto 500mm diameter fans
- Standard lengths 500mm (1D) & 1000mm (2D)
- Use up to 70°C (standard construction)
- Systems up to 1000 Pascals
- Special lengths on request

### INSERTION LOSS (dB) - CENTRE BAND FREQUENCY

PRODUCT CODE	63 Hz	125 Hz	250 Hz	500 Hz	1000 Hz	2000 Hz	4000 Hz	8000 Hz
CP03-C*-0500-1D	2	3	6	14	14	12	10	5
CP03-C*-0500-2D	3	7	8	19	20	17	14	11
CP03-C*P-0500-1D	2	7	9	17	24	24	20	16
CP03-C*P-0500-2D	4	10	16	26	29	29	29	20

Insertion loss data is derived from continual testing to BS4718 and other standards in independent UKAS certified laboratories, which includes where appropriate, re-generated or self noise testing in both forward and reverse flow conditions. If you request system analysis from our technicians all predictions will be assessed using the relevant certified insertion loss data together with relevant dynamic corrections.

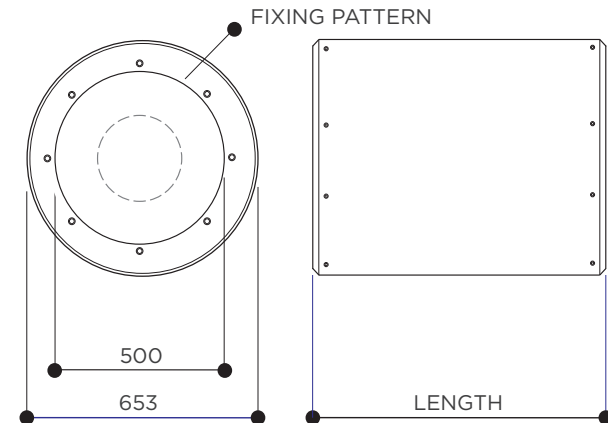

### DIMENSIONAL DATA

CODE	LENGTH	FIXING PATTERN	MASS
CP03-CA-0500-1D	500mm	12 x M10-560 PCD	18 Kg
CP03-CA-0500-2D	1000mm	12 x M10-560 PCD	32 Kg
CP03-CAP-0500-1D	500mm	12 x M10-560 PCD	22 Kg
CP03-CAP-0500-2D	1000mm	12 x M10-560 PCD	37 Kg
CP03-CB-0500-1D	500mm	12 x M8 - 541 PCD	18 Kg
CP03-CB-0500-2D	1000mm	12 x M8 - 541 PCD	32 Kg
CP03-CBP-0500-1D	500mm	12 x M8 - 541 PCD	22 Kg
CP03-CBP-0500-2D	1000mm	12 x M8 - 541 PCD	37 Kg

### MATERIAL & FINISH

All casings are manufactured from mill finish hot dip galvanised mild steel conforming to EN10327 (BS2989) including the flow formed one piece end fittings. To prevent erosion of absorbing materials the C Series Silencers are fitted with a perforated liner manufactured from galvanised mild steel conforming to EN10327 (BS2989). The C Series Silencers utilise acoustic grade mineral fibre absorbing infill and are manufactured to the HVCA specification DW144 class B and M&E 100 for sheet steel thickness and stiffening.

**Pressure** Up to 1000 Pascals positive and negative.  
**Temperature** -12° to +70° C.  
**Location** Internally & externally mountable.

### MELINEX LINING (OPTIONAL)

Where moist conditions exist (e.g. process systems) or for critically clean applications (e.g. hospitals) the sound absorbing material may be required to be fully sealed by Melinex lining to prevent fibre migration. This will however, effect the acoustic performance of the silencer. Please contact us to discuss your requirements.

### ALTERNATE SPECIFICATION

The above specification refers to our standard stock range. We can also supply custom made C Series Silencers with alternative dimensions, temperature ratings, construction materials and product finishes. Please contact us for further information and advice.

### PRODUCT CODE GUIDE

Example: **CP03-CAP-0500-2D**

**CP03** Product Group Code  
**CA** Drilling Pattern CA for A or CB for B  
**0500** Internal Diameter  
**2D** Length code 1D = 500, 2D = 1000

### RESISTANCE TO AIRFLOW (Pa)

AIR VOLUME M <sup>3</sup> /s	0.5	0.6	0.8	1.0	1.3
CP03-C*-0500-1D	-	-	-	-	-
CP03-C*-0500-2D	-	-	-	-	-
CP03-C*P-0500-1D	10	24	40	80	120
CP03-C*P-0500-2D	21	36	61	124	188

- represents a negligible resistance to airflow that can be assumed to be equivalent to a duct section of the same length.

### INSTALLATION

For recommendations for the support of the silencer the principles of Part Six (pages 43-46) of the HVCA DW144 standard should be followed. It is important that the recommendations in the table are adhered to when locating the silencer in relation to other duct-mounted equipment. If the silencers are to be used in conjunction with equipment not listed please enquire for advice.

ITEM	LOCATION
Centrifugal Fans	Direct couple only at the same size; use an inlet cone if open after silencer. PODDED - position one duct diameter from fan inlet / outlet.
Axial Fans	Direct couple only at the same size. Use an inlet cone if open after silencer. PODDED - match hub size within 30% of half nominal diameter.
Mixed-Flow Fans	Direct couple only at the same size. Use an inlet cone if open after silencer.
Ductwork Bends	Direct couple only at the same size. PODDED - position two duct diameters from bend.
Ductwork Reducers	Direct couple only with reducers of maximum 15° cheek slope.
Finned Coils & Filters	Leave 200mm plenum between silencer and coil or filter, and suitable reducer as specified in HVCA DW/144 1998.

### MAINTENANCE

Silencers are of a passive nature and as such require no routine maintenance or lubrication.

### INSPECTION

For inspection access the recommendations set out in Heating & Ventilating Contractors Association specification DW144 1998, appendix M – Guidance Notes for Inspection, Servicing and Cleaning Access Openings, should be followed. We would suggest Level 2 one 300mm x 200mm-inspection panel down-stream or Level 3 one 300mm x 200mm inspection door each side of the silencer. Refer to table 25 of DW144 or Section 2 of HVCA specification TR17 for further recommendations.

It is our recommendation that the silencers are inspected periodically to ensure that the airways are free from obstructions and no dust or foreign matter has collected and blocked the holes in the perforated liner elements.

### CLEANING

Should airways require routine cleaning we recommend low-pressure air blasting, vacuuming or wiping the exposed surfaces with a damp cloth. It is not unusual for “White Zinc Oxide” to develop on galvanised silencers when the zinc in the galvanising reacts electrolytically with moisture.