

Internal Room Elevation

Scale: 1:10

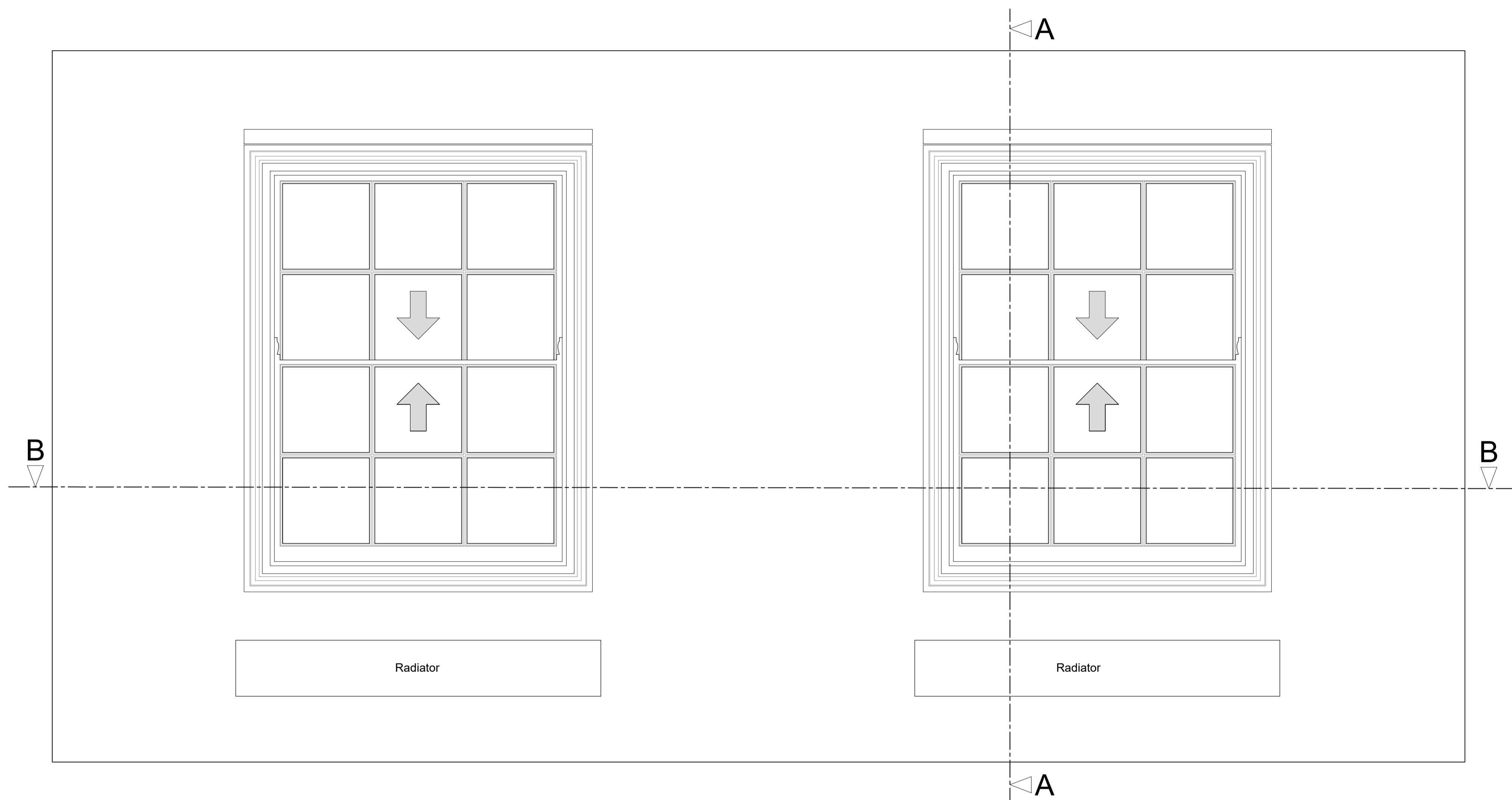

Section A-A through External Wall

Scale: 1:10

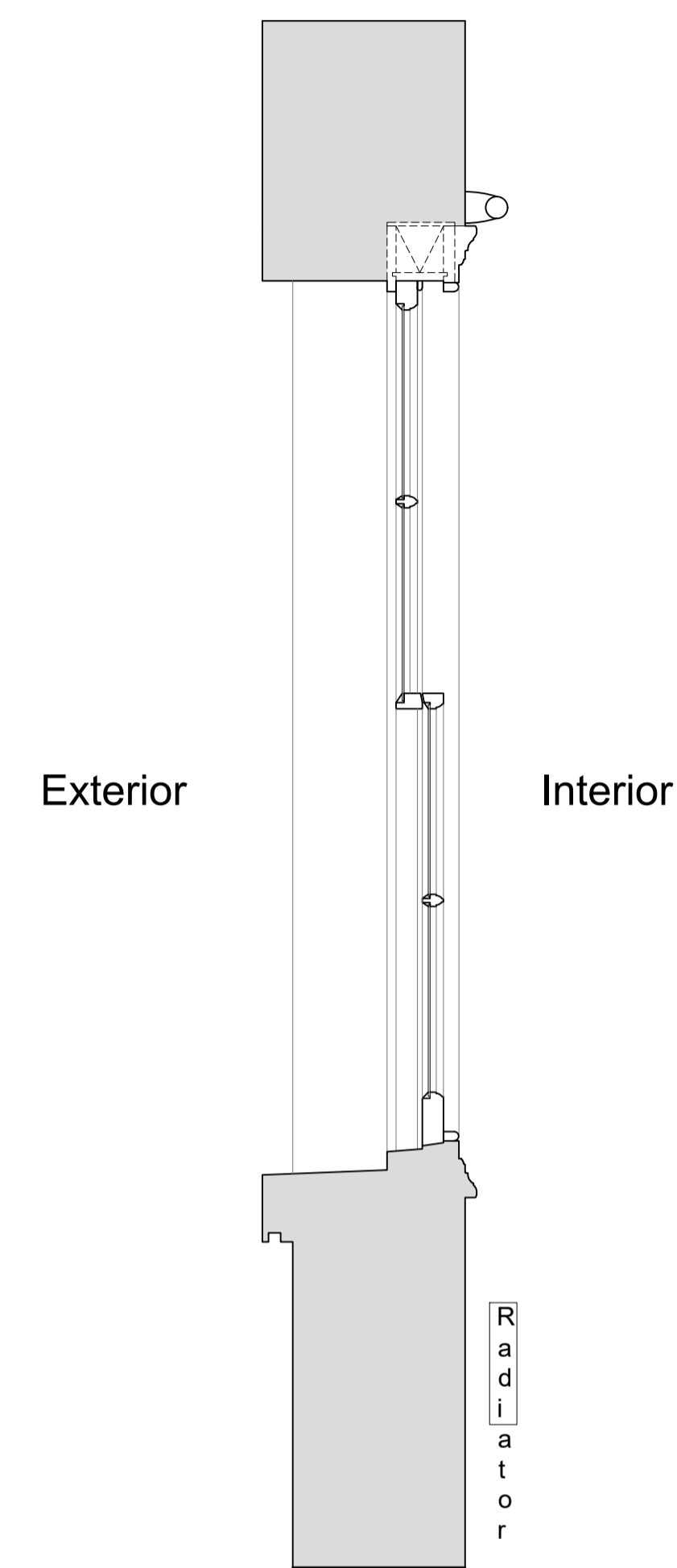

Plan Section B-B

Scale: 1:10

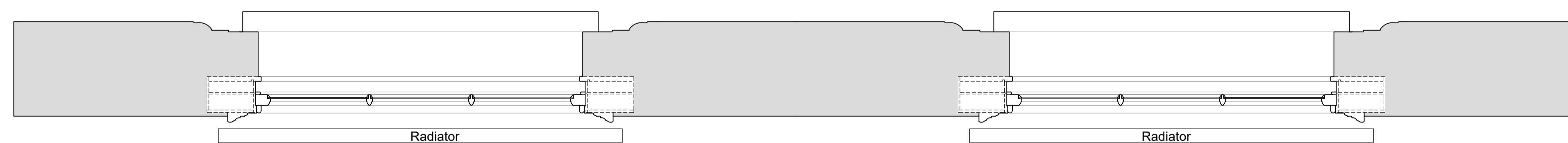

Revision	Date	Assessment
1.0	18-04-2019	Issued for listed building consent application
2.0	06-10-2019	Issued for listed building consent application

Do not reproduce this drawing without written permission
All dimensions are in millimetres unless stated otherwise

HS2

High Speed (HS2) Limited
1st-3rd Floor
The Podium
1 Eversholt Street
London NW1 2DN

COSTAIN SKANSKA

Costain Skanska Joint Venture
9th Floor
The Tower
1 Eversholt Street
London NW1 2DN

Site Address:
26 Morningside Terrace, Flat 4, London NW1

Drawing Title:
Second Floor - Lounge: EXISTING Window Joinery Details -
Sheet 1 of 3

Drawn by: AP & PB
Checked by: OB
Presentation Scale: as shown @ A1

Date: 16-04-2019
Drawing No: WPI P066 NI - 26 MT-EX-SF-J-04
Revision: 2.0

Drawing Not For Construction

Internal Room Elevation with Secondary Glazing Installed

Scale: 1:10

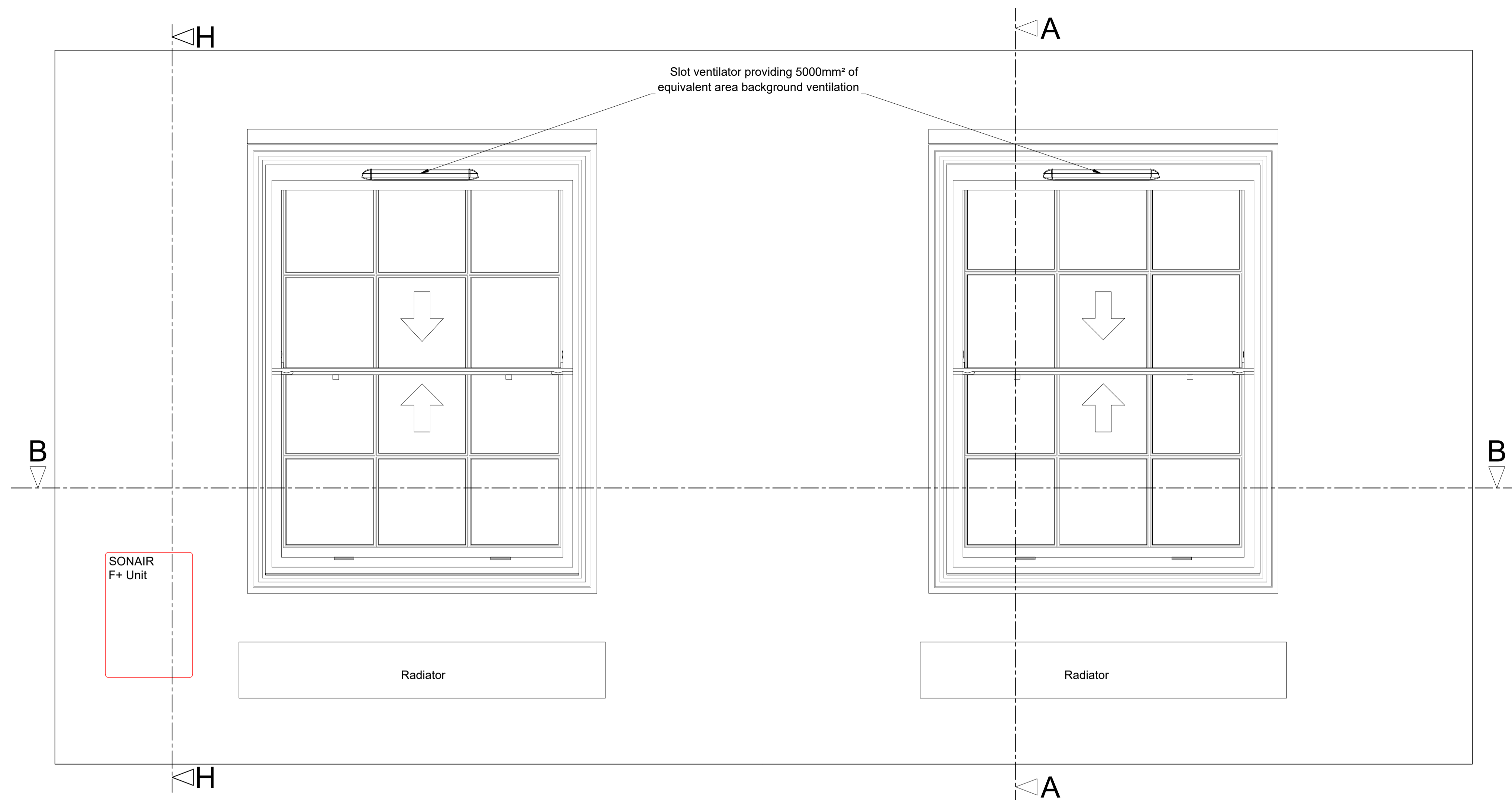

Section A-A through External Wall with Secondary Glazing Installed

Scale: 1:10

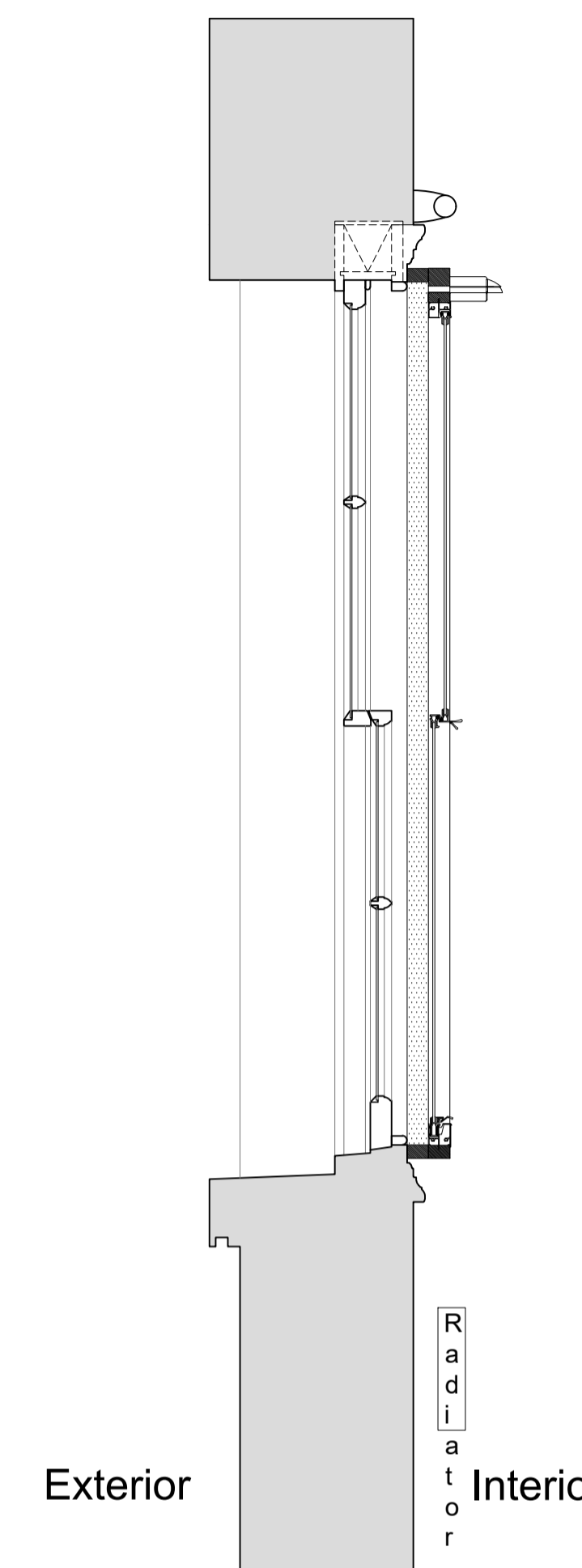

Section H-H through External Wall with Mechanical Ventilation Installed

Scale: 1:10

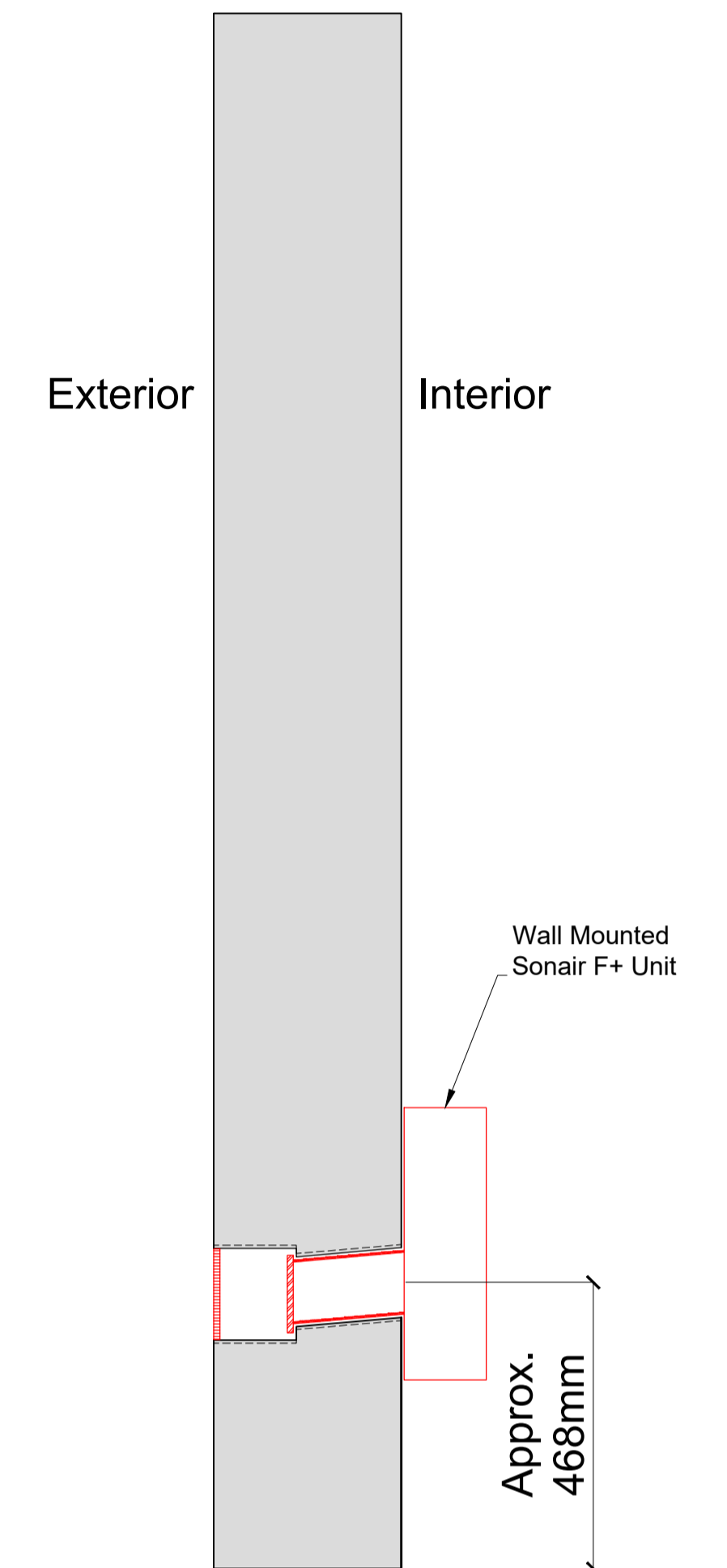

Plan Section B-B with Secondary Glazing Installed

Scale: 1:10

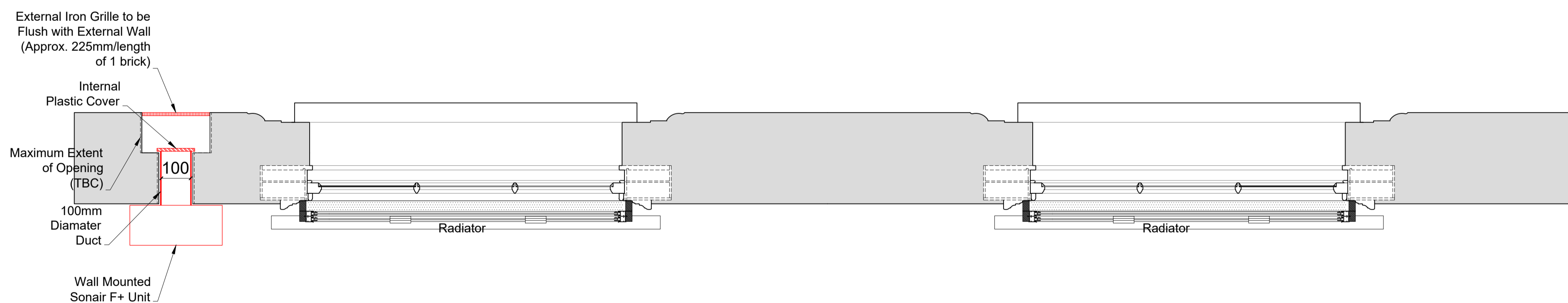

SECONDARY GLAZING SHOWN IN RED FOR VISUAL CLARITY ONLY

Detail of Sonair Unit

Scale: 1:5

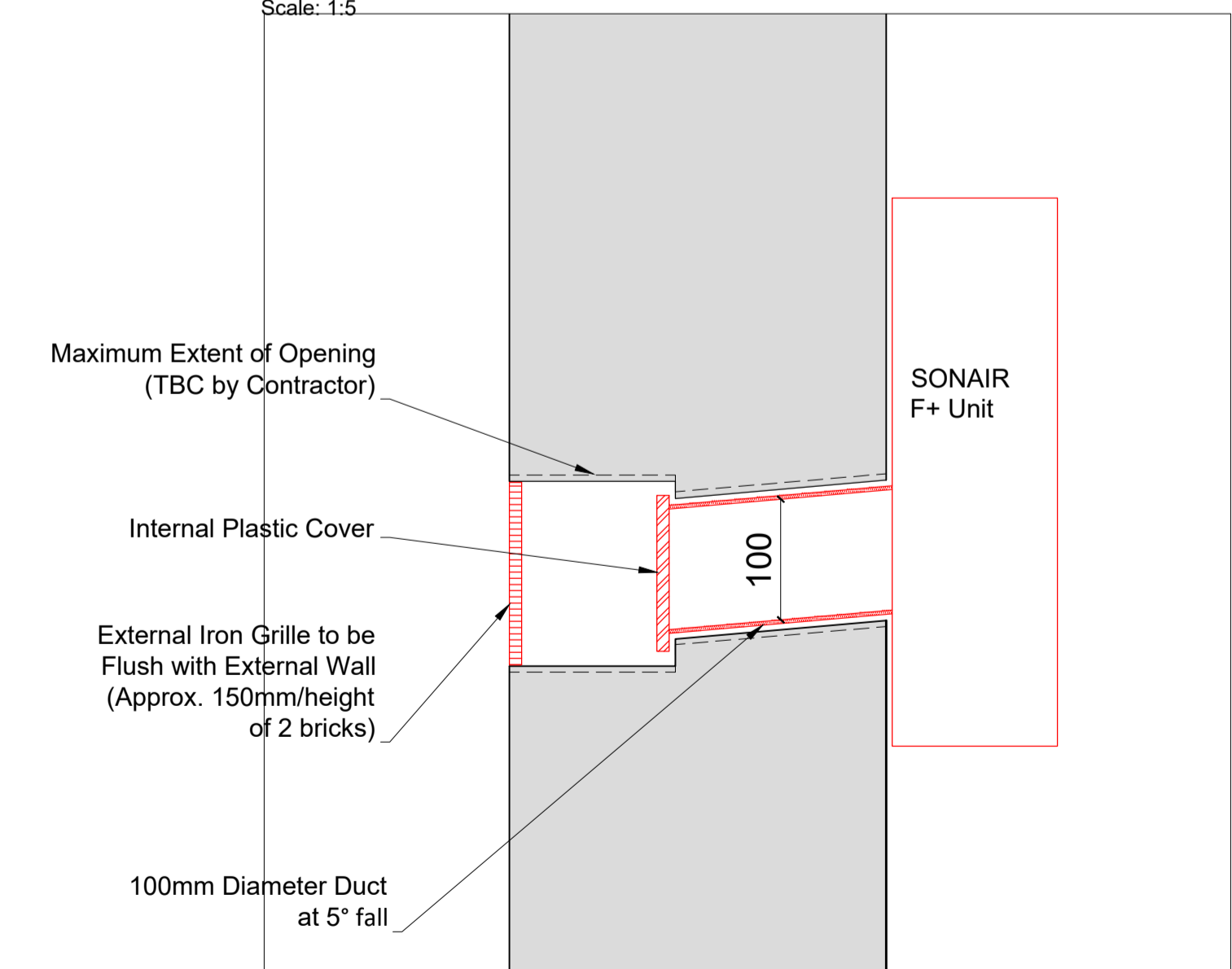

Revision	Date	Assessment
1.0	18-04-2019	Issued for listed building consent application
2.0	06-10-2019	Issued for listed building consent application

Do not reproduce this drawing without written permission
All dimensions are in millimetres unless stated otherwise

HS2

High Speed (HS2) Limited
1st-3rd Floor
The Podium
1 Eversholt Street
London NW1 2DN

COSTAIN SKANSKA

Costain Skanska Joint Venture
9th Floor
The Tower
1 Eversholt Street
London NW1 2DN

Site Address:
26 Mornington Terrace, Flat 4, London NW1

Drawing Title:
Second Floor - Lounge: PROPOSED Secondary Glazing Details - Sheet 2 of 3

Drawn by: AP & PB
Checked by: OB
Presentation Scale: as shown @ A1

Date: 16-04-2019
Drawing No: WPI P066 NI - 26 MT-PR-SF-J-04.1
Revision: 2.0

Drawing Not For Construction