

Plaster elements

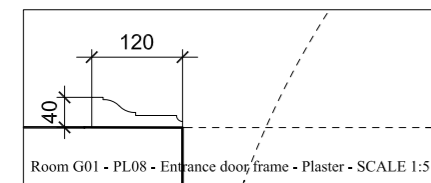

Wooden elements

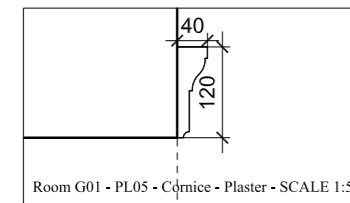
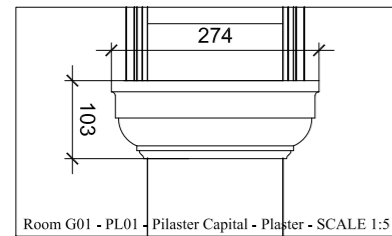
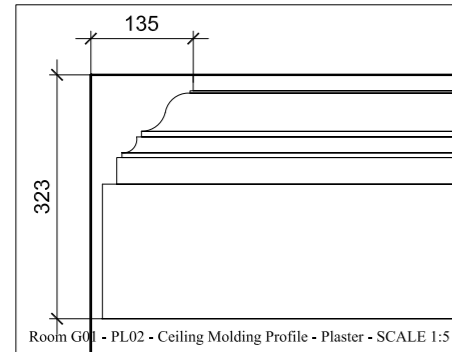
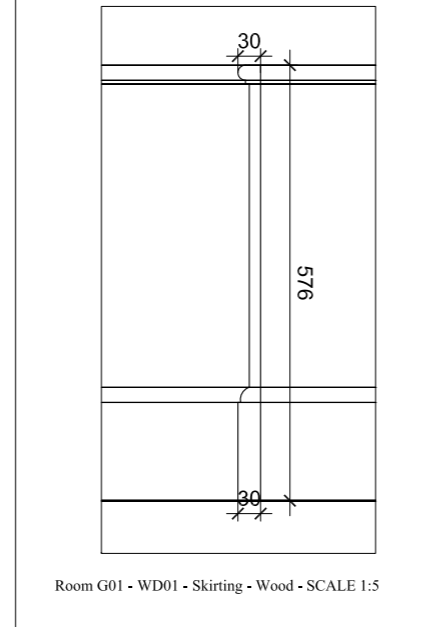

Wooden elements

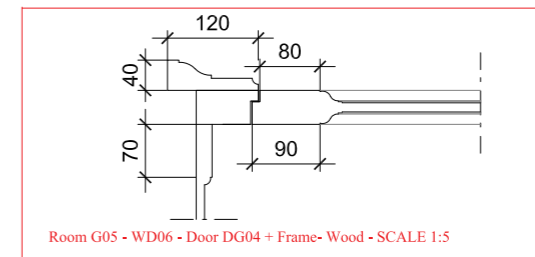
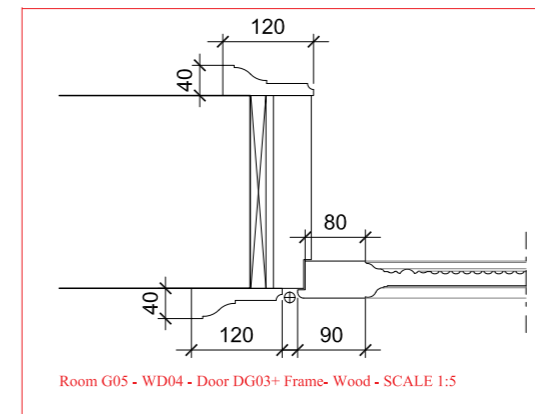
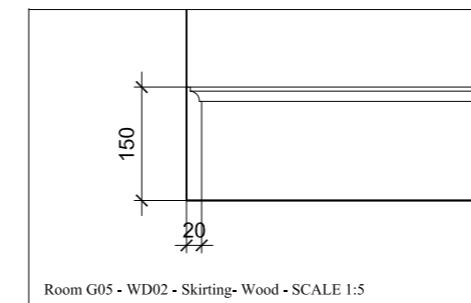
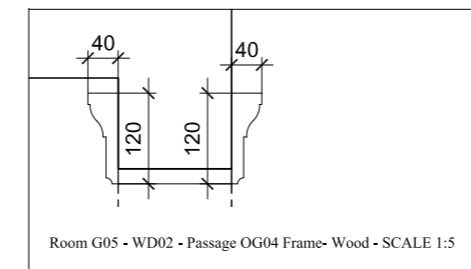
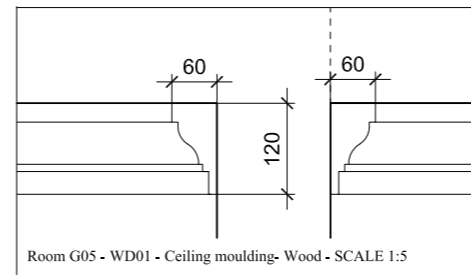

PLANNING ISSUE

REV.	DATE	DESCRIPTION
------	------	-------------

36-37 CHESTER TERRACE
LONDON

GROUND FLOOR
CORNICE & SKIRTING DETAILS

DRNG No	SCALE	DATE
PL-56	15/120 @ A3	AUG 2020



5 ST. JAMES'S SQUARE
LONDON SW1Y 4JU
T 020 7451 0955 mail@stanhopegate.co.uk
www.stanhopegatearchitecture.com