

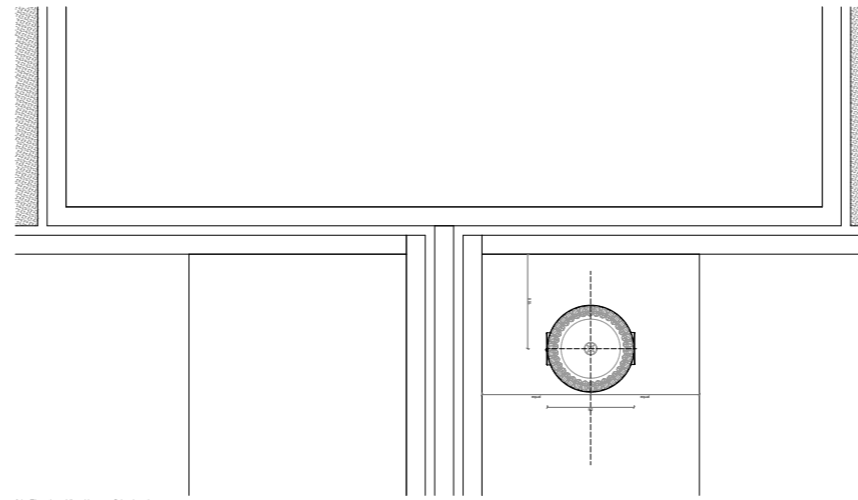

Proposed sixth floor terrace light
Lightgraphics LD10238

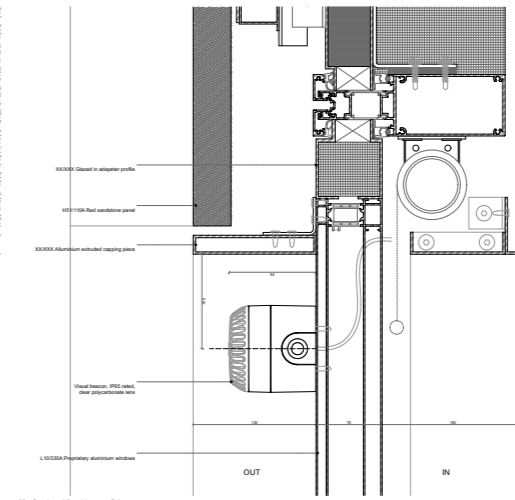

01 - Elevation - Visual beacon fixing location



02 - Section - Visual beacon fixing

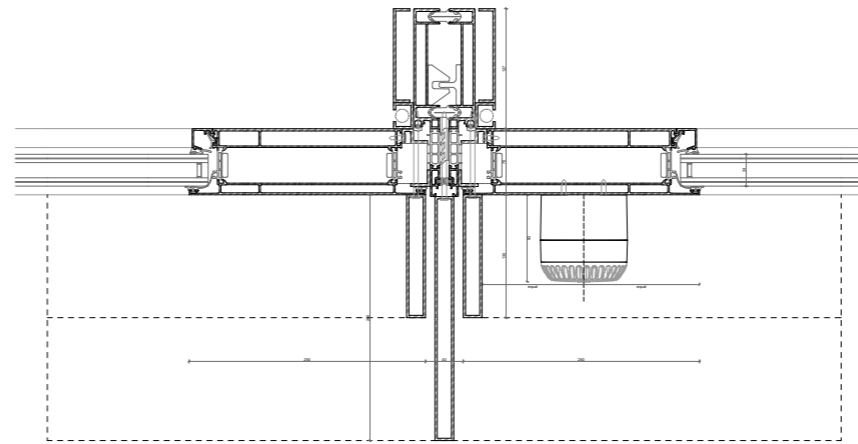

01 - Elevation - Visual beacon fixing location

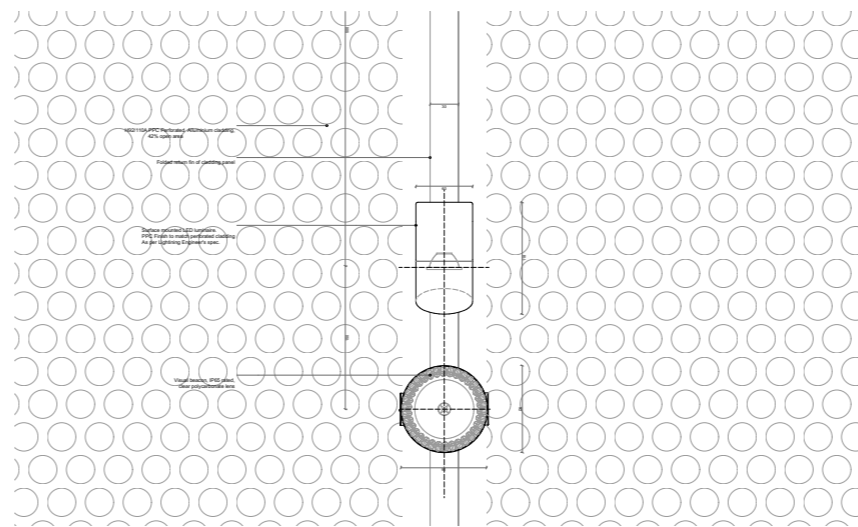

Detailed drawing showing the position of emergency beacons on the terraces of the fourth and fifth floors as well as the position of the light and beacon on the sixth floor.

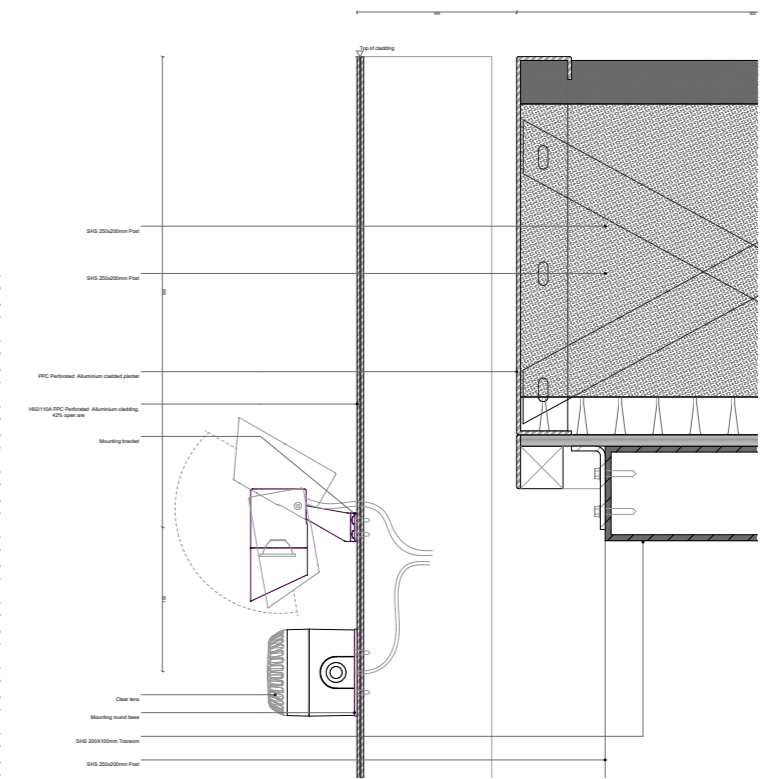

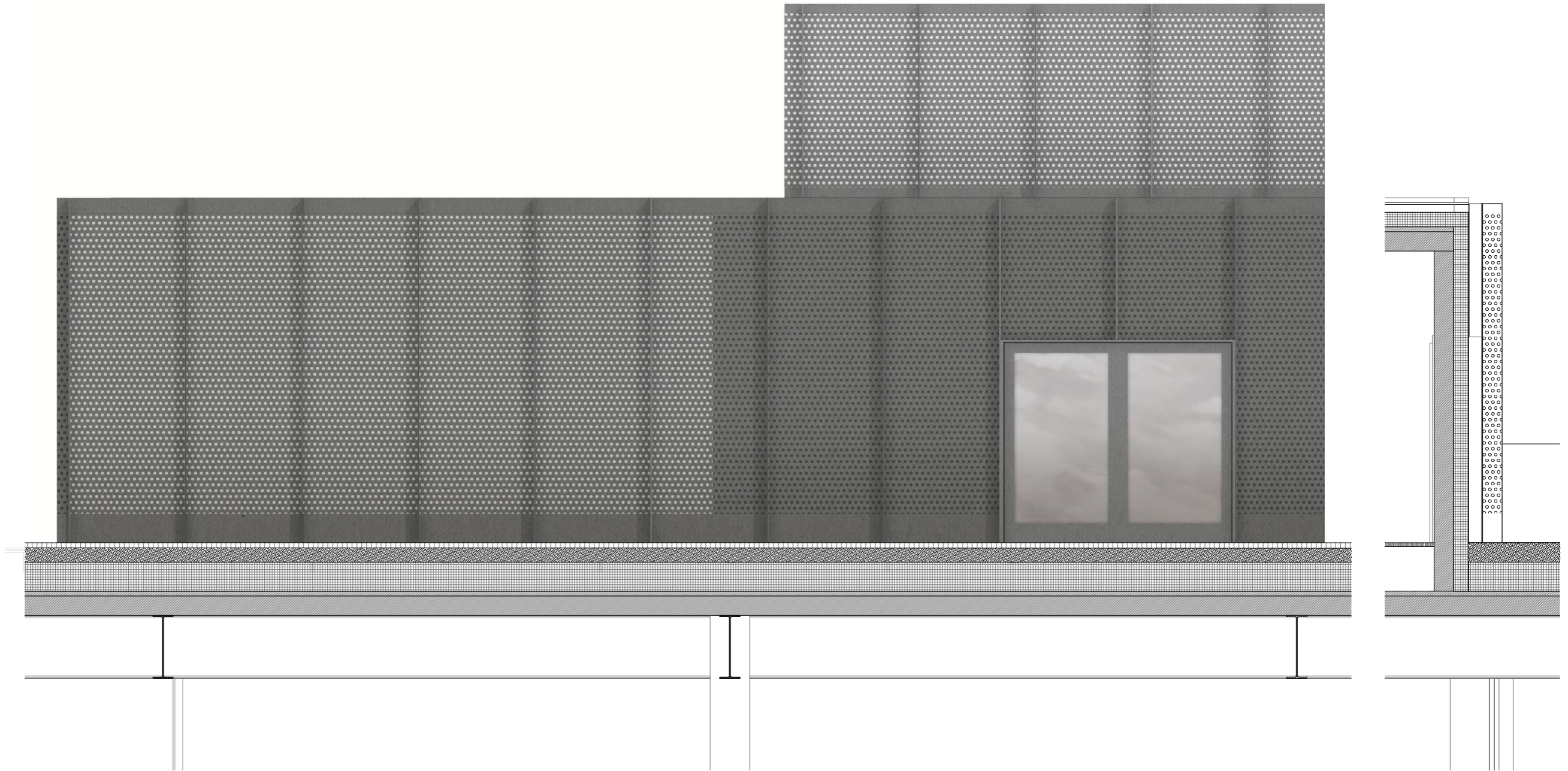

Elevation of sixth floor south elevation approved in December 2020



Revised Elevation of sixth floor south elevation