

VMZ Single Lock Standing Seam

Specification of details



Myamyn Residence, Armadale - Anthra-zinc Standing Seam, Architect: Nicholas Murray Architects
Installed by Advanced Metal Cladding

Technique information

Cladding technique	VMZ Single Lock Standing Seam
Cladding material	<ul style="list-style-type: none"> • Natural Mill finish, and Azengar® engraved zinc • pre-weathered QUARTZ-ZINC® PLUS® • pre-weathered ANTHRA-ZINC® PLUS® • PIGMENTO® PLUS® range available in 4 finishes: Autumn Red/Ash blue/Lichen Green/Brown
Support	15mm thick plywood
Underlay	Breathable waterproofing membrane
Ventilation	20mm unobstructed cavity created by vertical battens/galvanised steel top hats at 600mm centres
Panel width	430mm centre to centre maximum 263mm, 180mm to eliminate wastage from coil
Panel length	4 metres maximum, 2 metres maximum for soffits
Seam height	25mm
Sheet thickness	0.70mm, 0.80mm
Panel Weight	5.8/6kg per square metre

Please note:

Main structure and insulation by others.



Ceres Building - Auckland - Pigmento Brown Standing Seam, Architect: Williams Architects - Photo: Blair Hastings



The Snow Centre ACT - Quartz-zinc Standing Seam, Architect: Daryl Jackson Alastair Swain Architects - Installed by Erincole Facade Systems

The sole objective of this document is to describe the main technical features of VMZINC® product. Specification and installation of these products remains the exclusive competency of building professionals who must ensure that the use of these products is adjusted to the construction in question and compatible with the other products and techniques used. Specification and installation of the products implies compliance with the current norms and recommendations of the manufacturer. In this respect, VMZINC publishes specifications and installation guides that are regularly updated for specific geographical zones, and also organises training courses. All details may be obtained on request from the local VMZINC® team. VMZINC may not be held responsible for any specification or use that does not comply with these norms, recommendations and practices.

VMZINC

Phone: (02) 9358 6100
vmzinc.australia@umicore.com
www.vmzinc.com.au
www.vmzinc.co.nz

VM BUILDING SOLUTIONS

Panel Connection and clips

TYPICAL CROSS SECTION

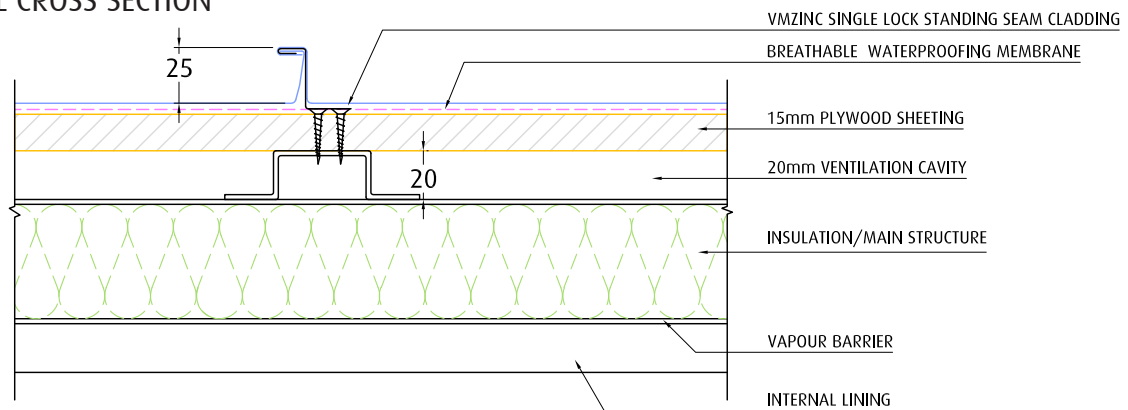

FIXING CLIPS

VMZINC sliding clip

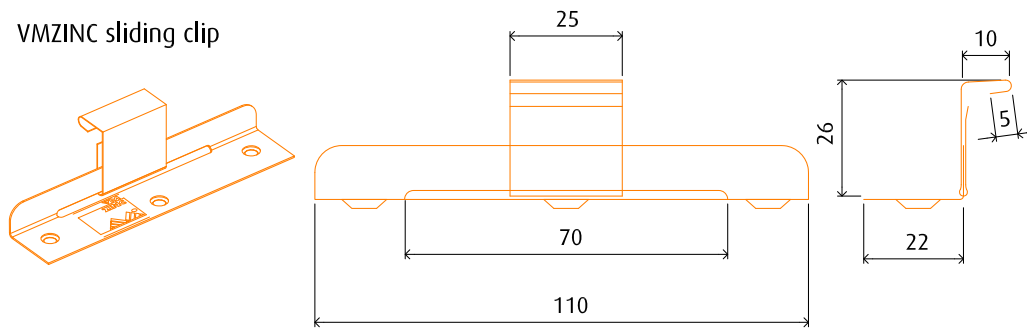

VMZINC fixed clip

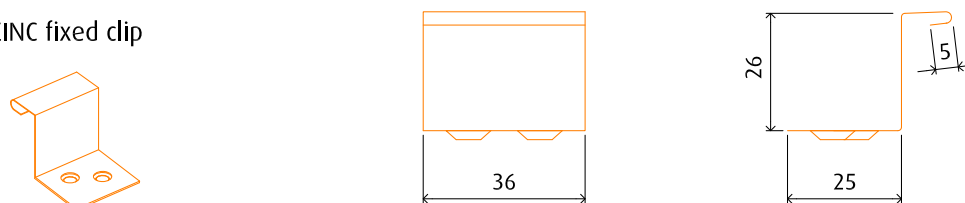

SINGLE WELT TRANSVERSAL JUNCTION

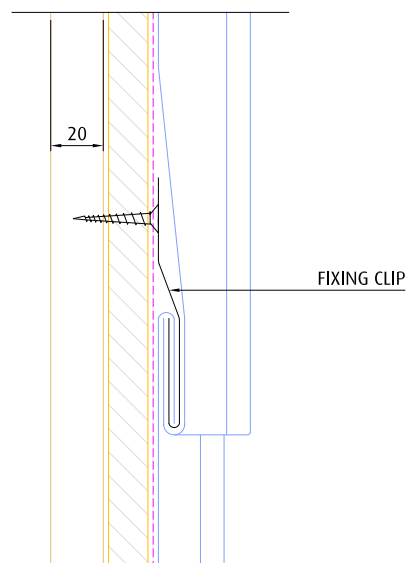

NOTE: MAIN STRUCTURE, INSULATION AND WATERPROOF MEMBRANE BY OTHERS

VMZ Single Lock Standing Seam Vertical

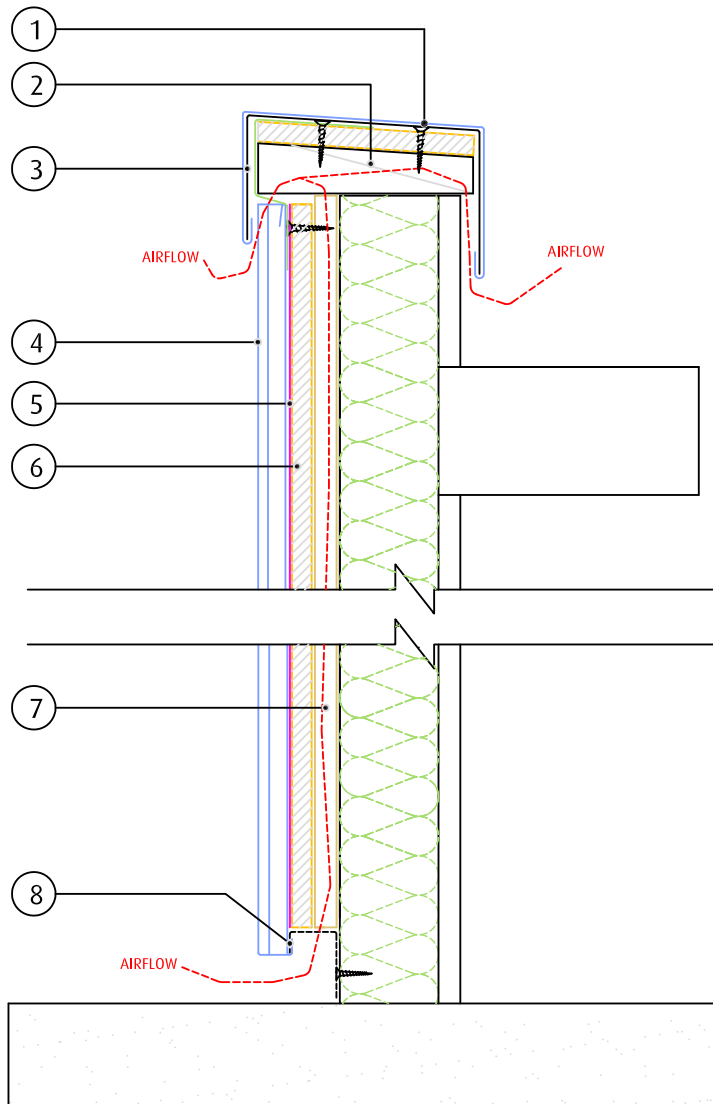

Parapet capping

1. VMZINC Parapet capping
2. Timber blocking
3. Galvanised steel stiffener
4. VMZINC Single Lock Standing Seam panel
5. Breathable waterproofing membrane
6. 15mm plywood sheeting
7. 20mm ventilation cavity
8. Perforated flashing strip

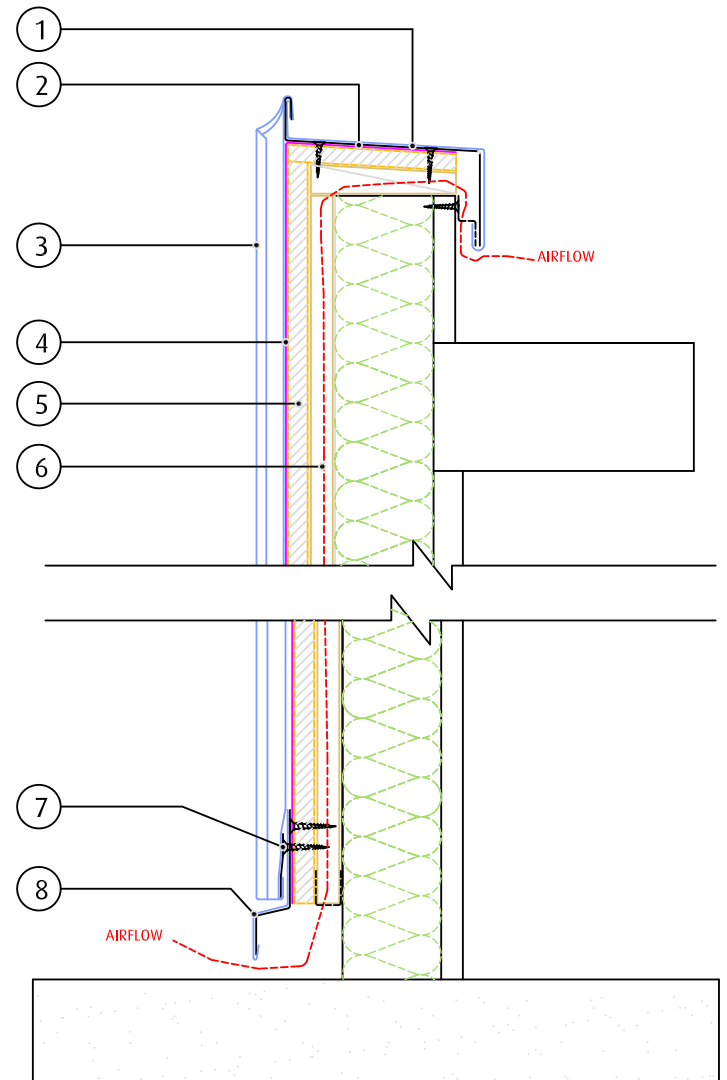

Parapet - seam capping

1. VMZINC Parapet capping
2. Galvanised steel stiffener
3. VMZINC Single Lock Standing Seam panel
4. Breathable waterproofing membrane
5. 15mm plywood sheeting
6. 20mm ventilation cavity
7. Galvanised steel stiffener
8. VMZINC apron flashing

NOTE: MAIN STRUCTURE, INSULATION AND WATERPROOF MEMBRANE BY OTHERS

VMZ Single Lock Standing Seam Vertical

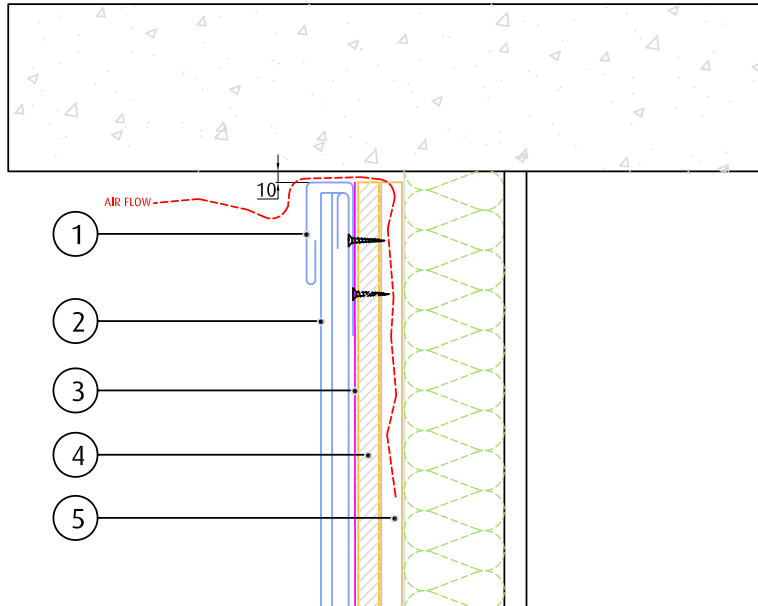

Top of wall @ soffit

1. VMZINC Top of wall flashing
2. VMZINC Single Lock Standing Seam panel
3. Breathable waterproofing membrane
4. 15mm plywood
5. 20mm ventilation cavity

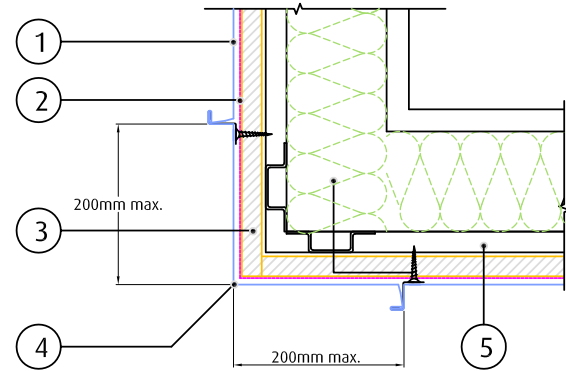

Exterior Corner - option 1

1. VMZINC Single Lock Standing Seam cladding
2. Breathable waterproofing membrane
3. 15mm plywood
4. VMZINC External corner panel
5. 20mm ventilation cavity

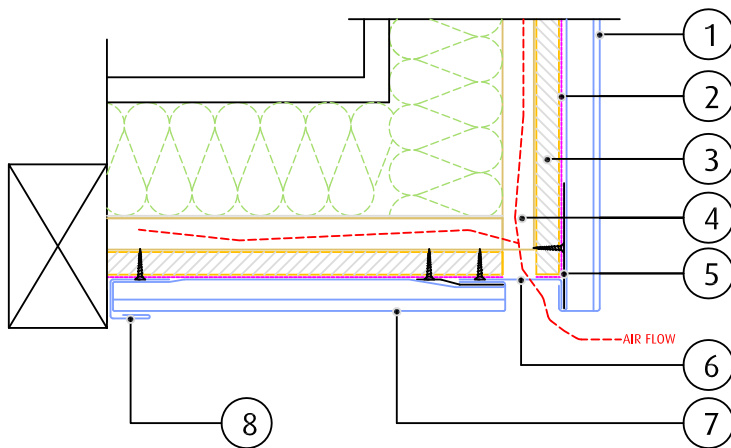

Soffit junction

1. VMZINC Single Lock Standing Seam cladding
2. Breathable waterproofing membrane
3. 15mm plywood
4. 20mm ventilation cavity
5. Galvanised steel stiffener
6. Perforated flashing strip
7. VMZINC Single Lock Standing Seam soffit
8. VMZINC securing clip

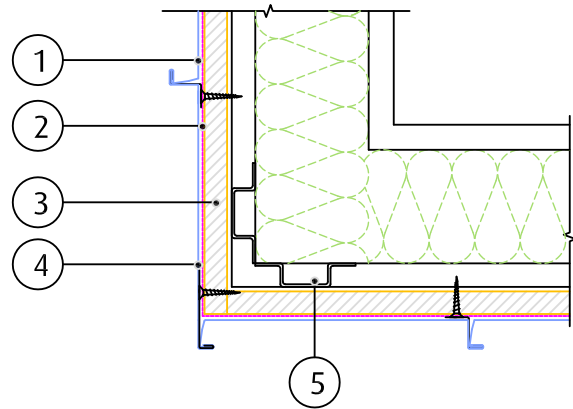

Exterior corner - option 2

1. VMZINC Single Lock Standing Seam cladding
2. Breathable waterproofing membrane
3. 15mm plywood
4. VMZINC External corner panel
5. 20mm ventilation cavity

NOTE: MAIN STRUCTURE, INSULATION AND WATERPROOF MEMBRANE BY OTHERS

VMZ Single Lock Standing Seam Vertical

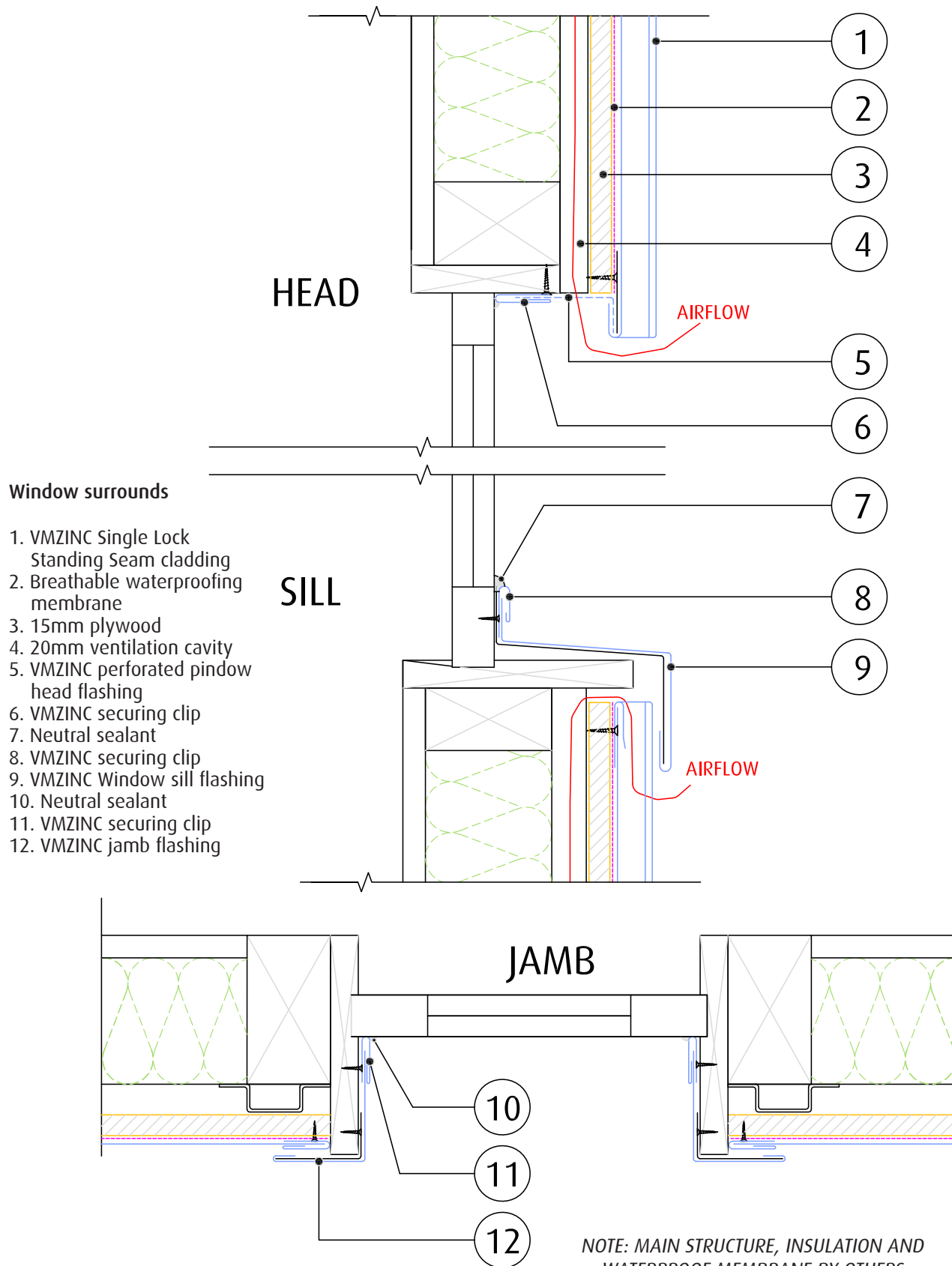

VMZ Single Lock Standing Seam Vertical

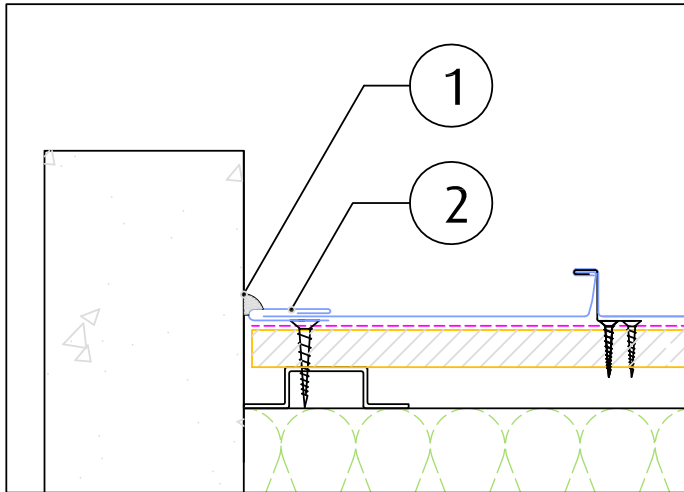

Wall Junction - Option 1

1. Neutral sealant
2. VMZINC securing clip

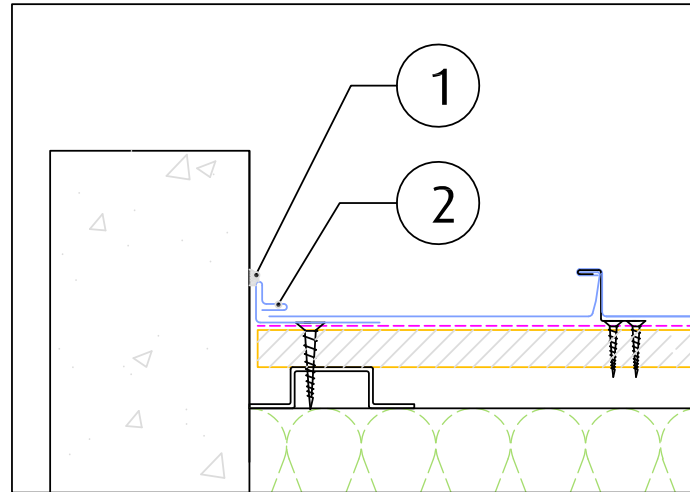

Wall Junction - Option 2

1. Neutral sealant
2. VMZINC securing clip

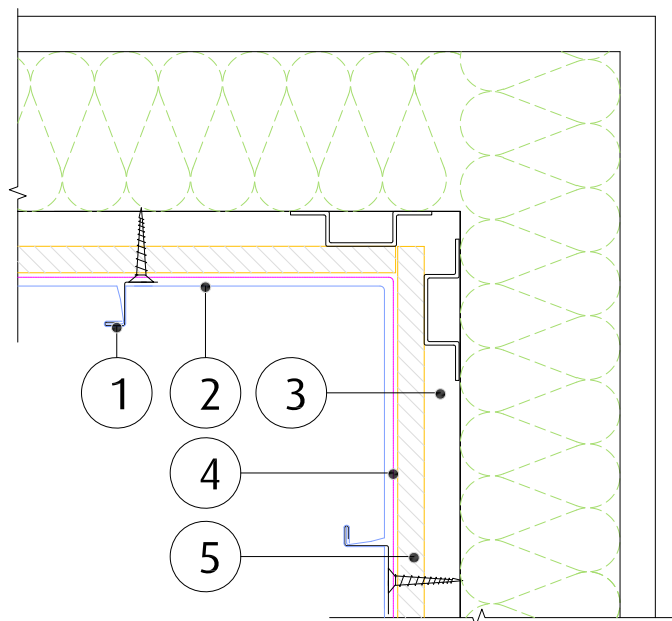

Interior Corner - Option 2

1. VMZINC Single Lock Standing Seam cladding
2. VMZINC Internal corner panel
3. 20mm ventilation cavity
4. Breathable waterproofing membrane
5. 15mm plywood sheeting

NOTE: MAIN STRUCTURE, INSULATION AND WATERPROOF MEMBRANE BY OTHERS

VMZ Single Lock Standing Seam Horizontal

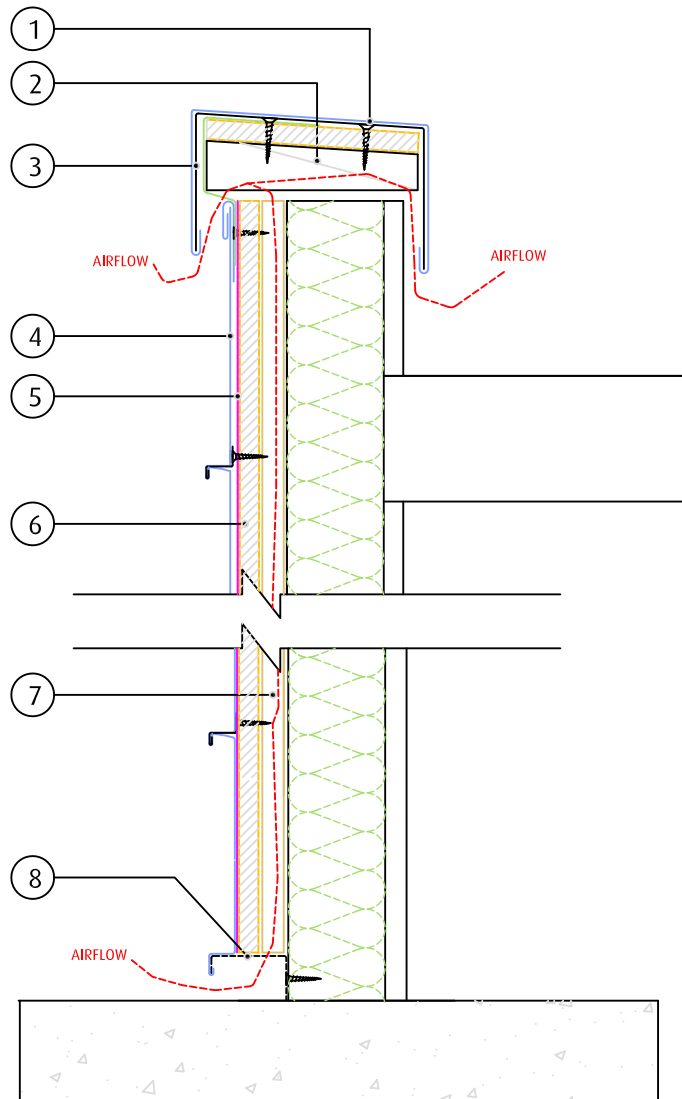

Parapet capping

1. VMZINC Parapet capping
2. Timber blocking
3. Galvanised steel stiffener
4. VMZINC Single Lock Standing Seam panel
5. Breathable waterproofing membrane
6. 15mm plywood sheathing
7. 20mm ventilation cavity
8. Perforated flashing strip

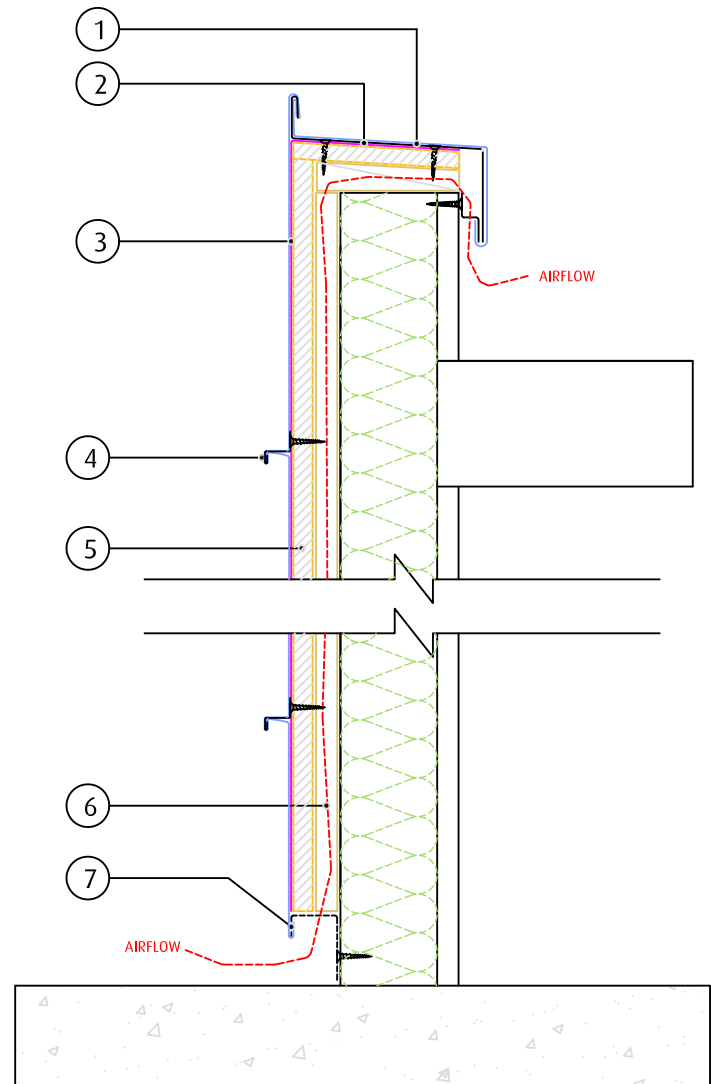

Parapet - seam capping

1. VMZINC Parapet capping
2. Galvanised steel stiffener
3. Breathable waterproofing membrane
4. VMZINC Single Lock Standing Seam panel
5. 15mm plywood sheathing
6. 20mm ventilation cavity
7. Perforated flashing strip

NOTE: MAIN STRUCTURE, INSULATION AND WATERPROOF MEMBRANE BY OTHERS

VMZ Single Lock Standing Seam Horizontal

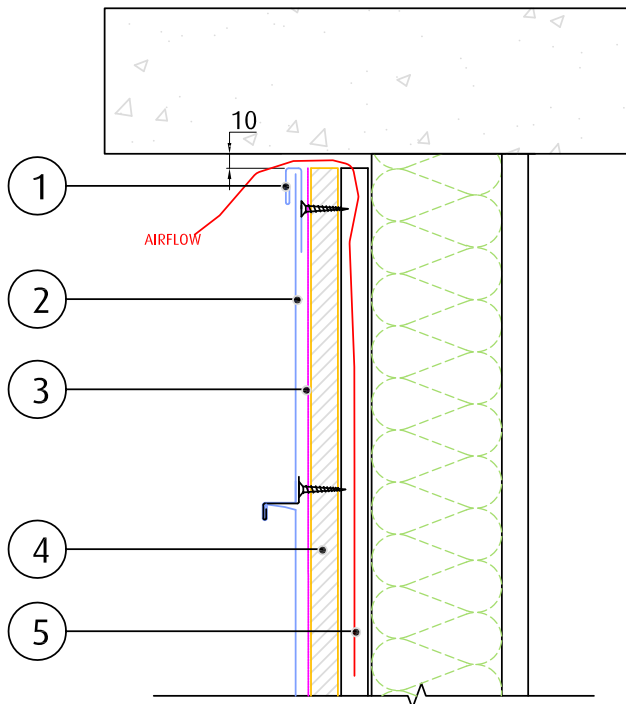

External Corner - Option 1

1. VMZINC Single Lock Standing Seam panel
2. Breathable waterproofing membrane
3. 15mm plywood
4. VMZINC External Corner flashing
5. 20mm ventilation cavity

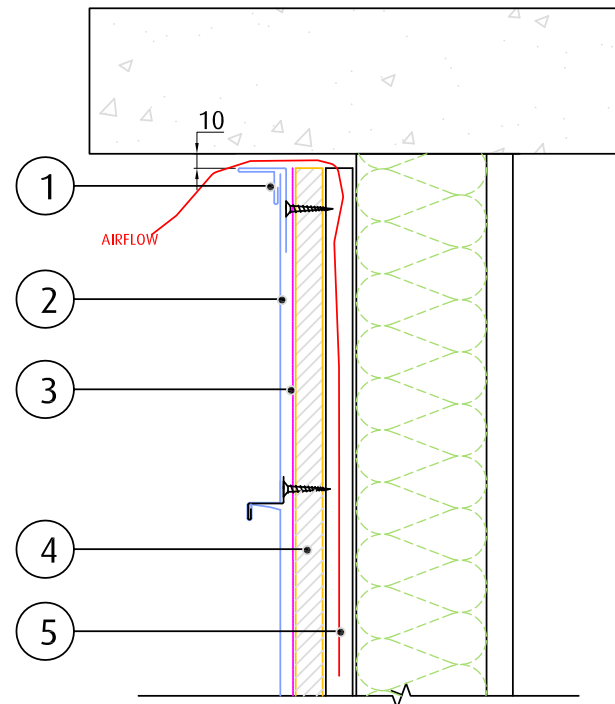

Exterior Corner - option 2

1. VMZINC Single Lock Standing Seam panel
2. Breathable waterproofing membrane
3. 15mm plywood
4. VMZINC Mitred Corner joint
5. 20mm ventilation cavity

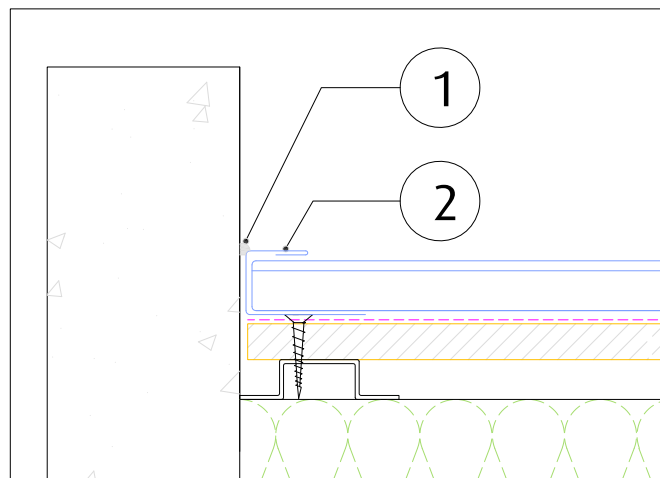

Wall Junction - Option 1

1. Neutral sealant
2. VMZINC securing clip

NOTE: MAIN STRUCTURE, INSULATION AND WATERPROOF MEMBRANE BY OTHERS

VMZ Single Lock Standing Seam Horizontal

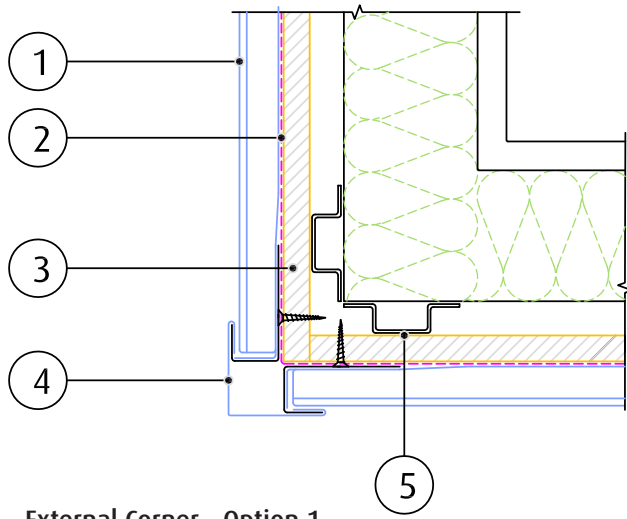

External Corner - Option 1

1. VMZINC Single Lock Standing Seam panel
2. Breathable waterproofing membrane
3. 15mm plywood
4. VMZINC External Corner flashing
5. 20mm ventilation cavity
5. VM ZINC Folded flashing strip

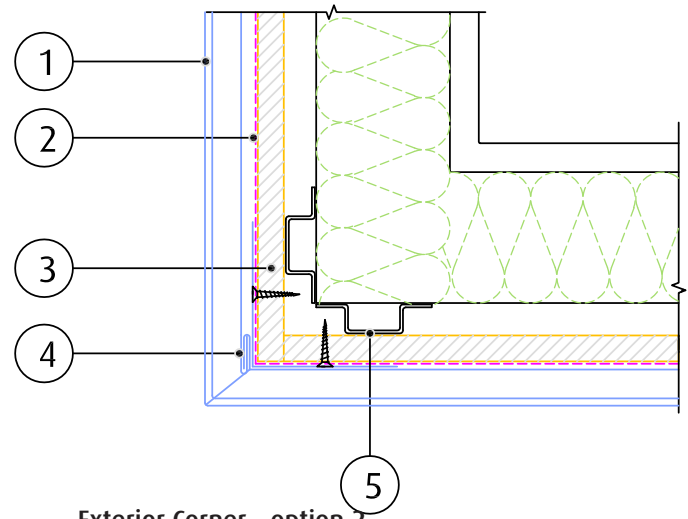

Exterior Corner - option 2

1. VMZINC Single Lock Standing Seam panel
2. Breathable waterproofing membrane
3. 15mm plywood
4. VMZINC Mitred Corner joint
5. 20mm ventilation cavity

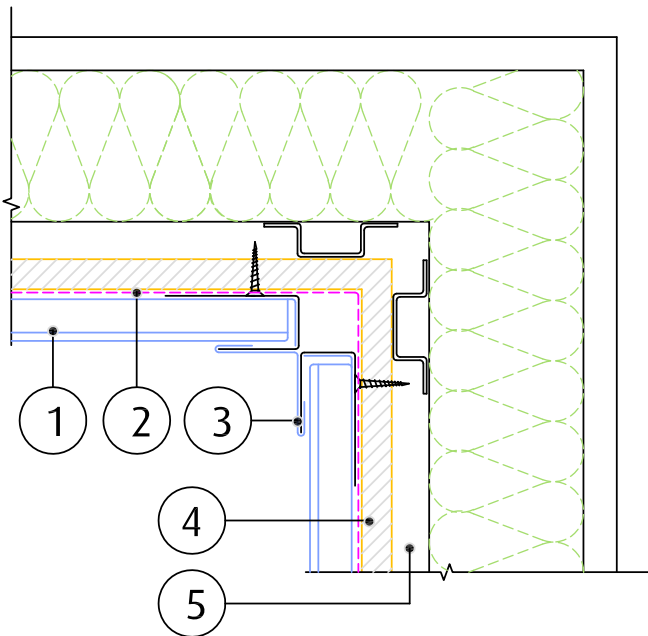

Internal Corner - Option 1

1. VMZINC Single Lock Standing Seam cladding
2. Breathable waterproofing membrane
3. VMZINC External Corner flashing
4. 15mm plywood
5. 20mm ventilation cavity

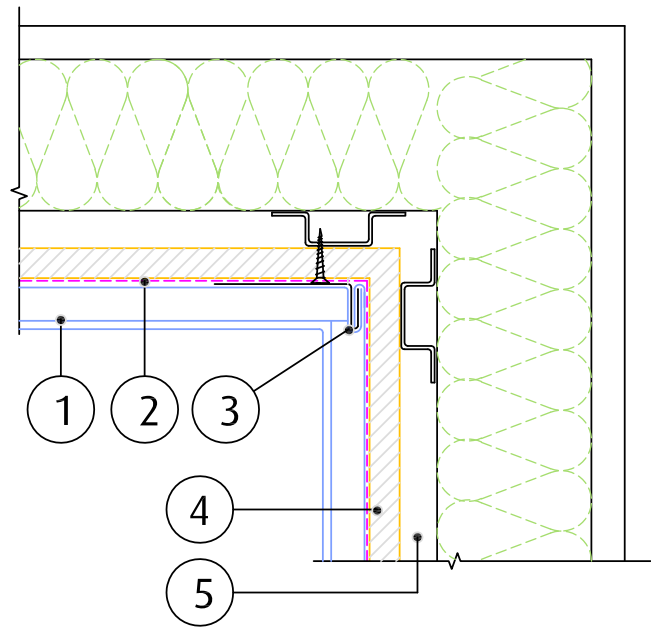

Internal corner - option 2

1. VMZINC Single Lock Standing Seam cladding
2. Breathable waterproofing membrane
3. 15mm plywood
4. VMZINC Internal corner joint
5. 20mm ventilation cavity

NOTE: MAIN STRUCTURE, INSULATION AND WATERPROOF MEMBRANE BY OTHERS

VMZ Single Lock Standing Seam Horizontal

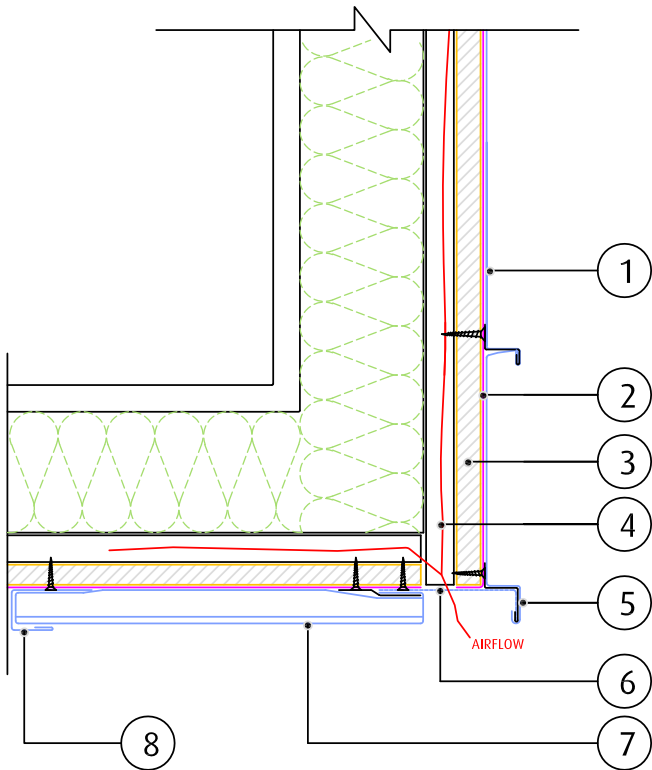

Soffit - Option 1

1. VMZINC Single Lock Standing Seam panel
2. Breathable waterproofing membrane
3. 15mm plywood
4. 20mm ventilation cavity
5. Seamed joint at soffit
6. Perforated flashing strip
7. VMZINC Single Lock Standing Seam soffit panel
8. VMZINC folded flashing strip

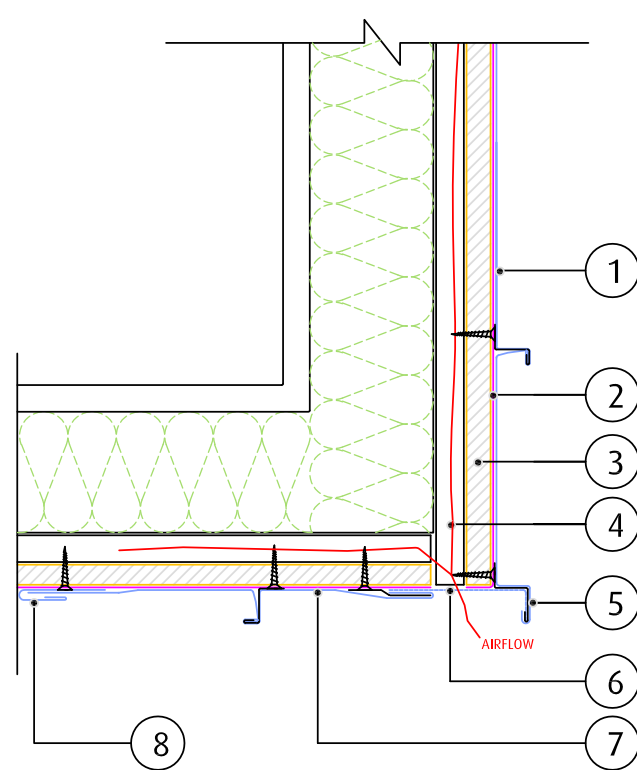

Soffit - Option 2

1. VMZINC Single Lock Standing Seam panel
2. Breathable waterproofing membrane
3. 15mm plywood
4. 20mm ventilation cavity
5. Seamed joint at soffit
6. Perforated flashing strip
7. VMZINC Single Lock Standing Seam soffit panel
8. VMZINC folded flashing strip

NOTE: MAIN STRUCTURE, INSULATION AND WATERPROOF MEMBRANE BY OTHERS

VMZ Single Lock Standing Seam Horizontal

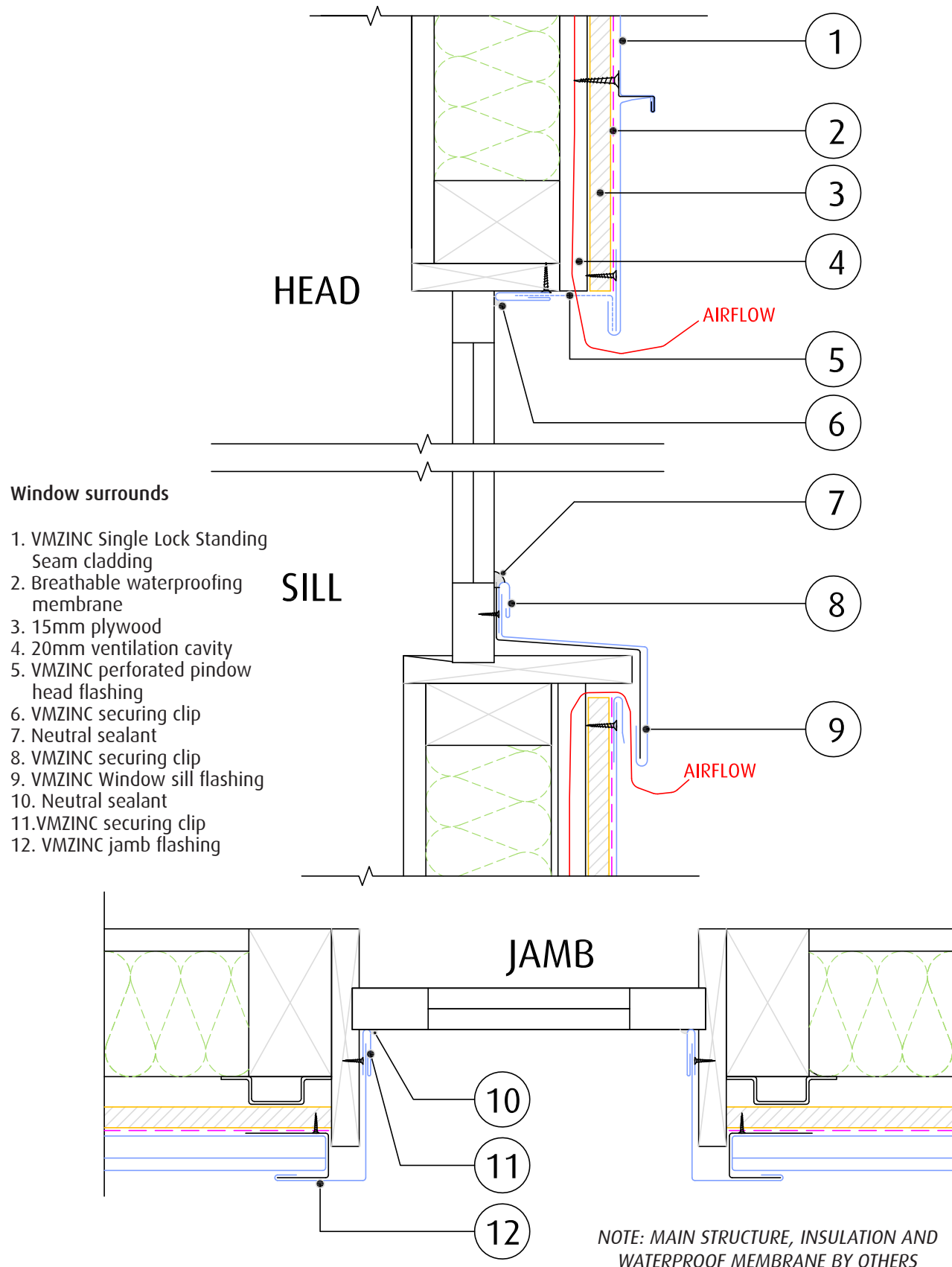



This document is intended for specifiers (building project and architect and design teams) and users (companies responsible for installation on the building site) of the designated product or system.

Its purpose is to provide the main information, text and diagrams, relating to specification and installation (including supporting structures) and flashing installation. Any use of specification outside the area and/or specifications contained in this manual requires specific consultation with the VMZINC technical departments.

This does not commit the latter to any responsibility with regard to the feasibility of the design or implementation of these projects.

Countries of application

This document applies exclusively to the specification and installation of the designated products or systems on building sites in Australia and New Zealand.

Qualifications and reference documents

Please note that the specification of all the construction systems for a given building remains the exclusive responsibility of its design team, who must, in particular, ensure that the specified products are suitable for the purpose of the building and compatible with the other products and techniques used.

Please note that the correct use of this manual requires knowledge of VMZINC materials and of the zinc roofing profession.

While construction is underway all standards in force must be respected.

Furthermore, VMZINC offers training courses specifically for professionals.

Responsibility

The specification and installation of VMZINC products are the sole responsibility of the architects and building professionals who must ensure these products are used in a way suited to the end purpose of the construction and that they are compatible with the other products and techniques used.

The specification and installation of the products implies respecting the standards in force and the manufacturer's recommendations. In this regard, VMZINC publishes and regularly updates specifications and installation manuals for specific geographic areas and provides training courses. All the information on the latter can be obtained from the local VMZINC team.

Unless otherwise agreed in writing, VMZINC cannot be held responsible for any damages resulting from a specification or installation that does not respect all of VMZINC's specifications and the above standards and practices.