

VERTICAL SECTION A-A

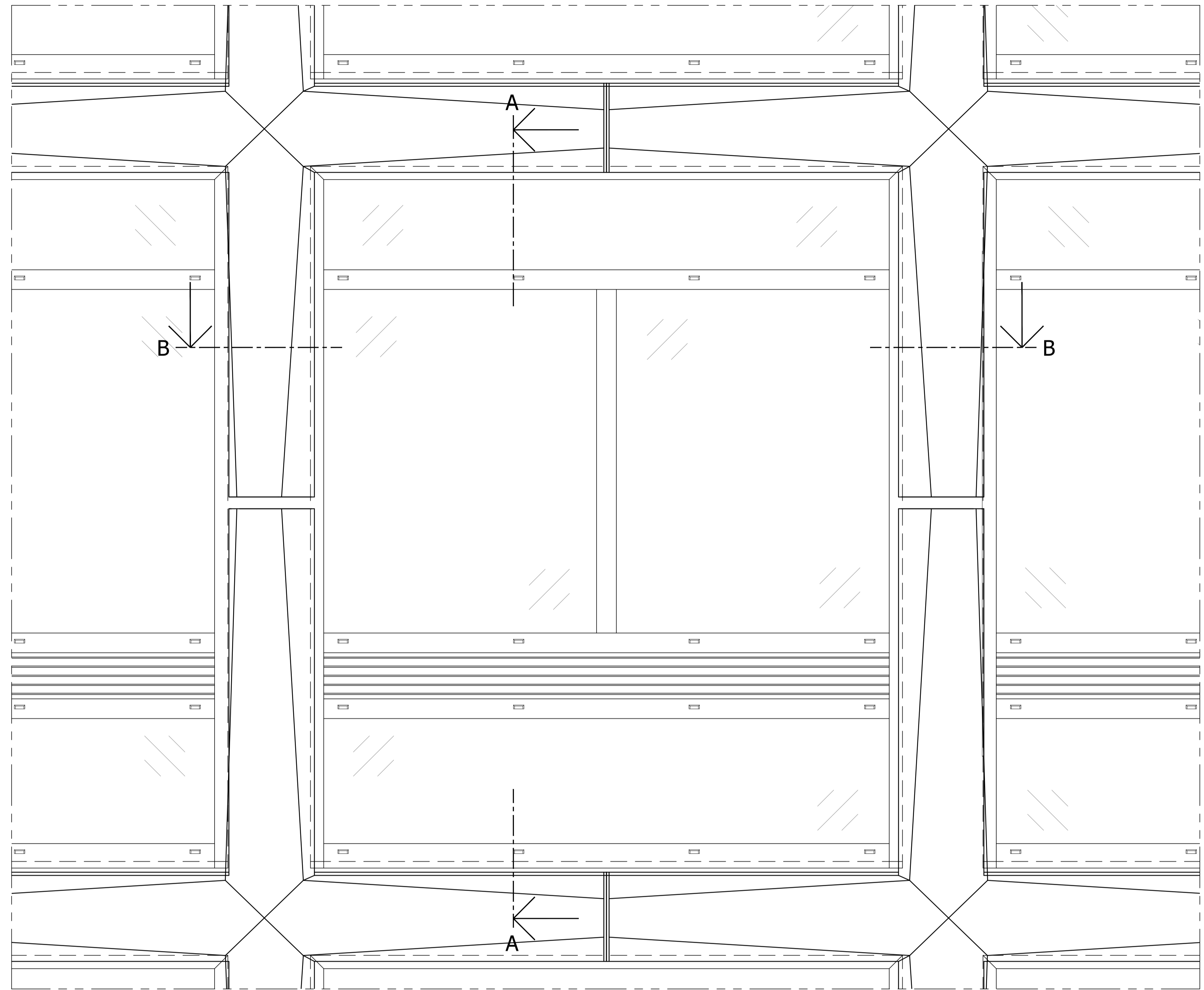

TOWER WINDOWS - EXTERNAL ELEVATION

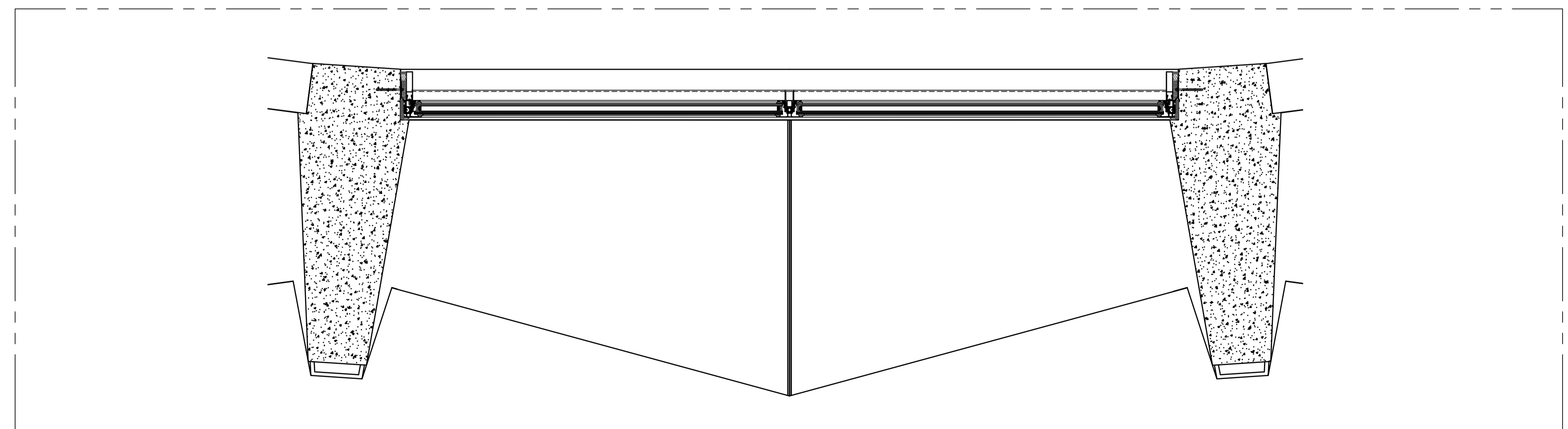

PLAN B-B

REFERENCE 50 100

Project	14015-CLL-T1-ZZ-DR-X-10101
Client	SPACEX
Scale	1:100
COLORMINIUM	
Author	AP
Checked	AP
Drawn	AP
Project	14015-CLL-T1-ZZ-DR-X-10101
Drawing Title	TOWER TYPICAL WINDOW DETAILS
Project	SPACE HOUSE
Contractor	
Date	22.07.2021
Scale	1:100 A3
Job No.	14015