



LIAM MCGOUGH  
TREE SERVICES Liam McGough Tree Services, 15a Bedford Road, N22 7AU



**LIAM MCGOUGH**  
T R E E   S E R V I C E S

## **BS5837 Arboriculture impact Report**

**Client: Khalid Rajab**

**Site location: 16a Ospringe Rd, NW5 2JE**

**Date: 27-04-2021**

**Prepared by Liam McGough FdSc Arb M ArborA Arb AC**



## Contents

<b>1.0 Introduction.....</b>	<b>2</b>
1.1 Scope & Brief .....	2
1.2 Limitations.....	3
1.3 Site Location .....	3
<b>2.0 Statutory Protection .....</b>	<b>4</b>
2.1 Tree Protection.....	4
2.2 Wildlife Protection .....	4
<b>3.0 Methodology .....</b>	<b>5</b>
3.1 Height .....	5
3.2 Age.....	5
3.3 DBH.....	5
3.4 Condition .....	6
3.5 Distance from property .....	6
3.6 Comments.....	6
3.7 Action.....	6
3.8 Priority .....	6
<b>4.0 Tree Survey Schedule.....</b>	<b>8</b>
4.1 Site description .....	8
4.2 Soil assessment.....	8
<b>5.0 Data Analysis .....</b>	<b>9</b>
5.1 Conclusion.....	9
<b>6.0 Arboricultural method statement.....</b>	<b>10</b>
<b>7.0 Glossary of Terms &amp; Definitions.....</b>	<b>10</b>
<b>8.0 Appendix</b>	



## 1.0 Introduction

### 1.1 Scope & Brief

A survey was carried out at the request of **Khalid Rajab** to assess the Arboricultural implications of development at **16a Ospringe Rd, NW5 2JE**

To note the effects that construction might have on trees within the boundary of this site or in surrounding properties. To advise on Protection of Trees and their roots as well as advise conditions of work and best practice to ensure tree protection. Notes on recommended tree work and the safe pruning of roots where granted construction meets Root protection areas.

The safety level of the trees based on their current status was also observed and recorded.

The purpose was to identify trees within the property boundary with regards to their risk level to public health and safety, potential ground disturbance if removed and what appropriate trees could be planted to replace any lost trees.

Subsequent works were recommended to alleviate any issues identified regarding root damage and or subsidence, and from a health and safety and property development perspective.

Trees requiring works were categorised as high, medium or low priority based on the methodology stated in **section 3.7**

The data recorded included, species (common name), height, DBH, crown spread in each direction, age, condition and distance of main stem from the property foundations. Detailed explanations of these criteria are in the methodology section of this report (**section 3**).

The data is recorded in the Tree Survey Schedule section (**section 4**) of this report and includes comments identifying any damage to property foundations, faults and hazards with respect to crown form, condition, storm damage and disease. A recommended action was given for each tree. No bore hole and DNA testing has been carried out for this report.

All works recommended should be carried out in accordance with BS 3998:2010 Tree Work - recommendations.

Individual trees are plotted on separate site plans and accompany each respective tree survey schedule (**section 4**), tree location plan in (**Appendix**).

## 1.2 Limitations

All observations were from ground level without detailed inspection and were not inspected from underground excavation or from an aerial perspective.

As trees are living organisms their health and condition can change rapidly. Extreme climate issues such as drought and flooding can affect soil shrinkage and overall tree health.

All statements made about the trees were based on the status of the trees at the time of inspection.

No bore hole testing or PICUS testing has been carried out at this site. All observations have been made using only visual indicators.

Trees with extensive ivy cladding were not thoroughly observed due to the difficulty to assess cavities and any hidden defects positioned underneath. With respect to this, the ivy should be severed to restrict its future growth and where applicable, removed to allow a detailed inspection to be carried out.

## 1.3 Site Location

16 Ospringe Rd, NW5 2JE

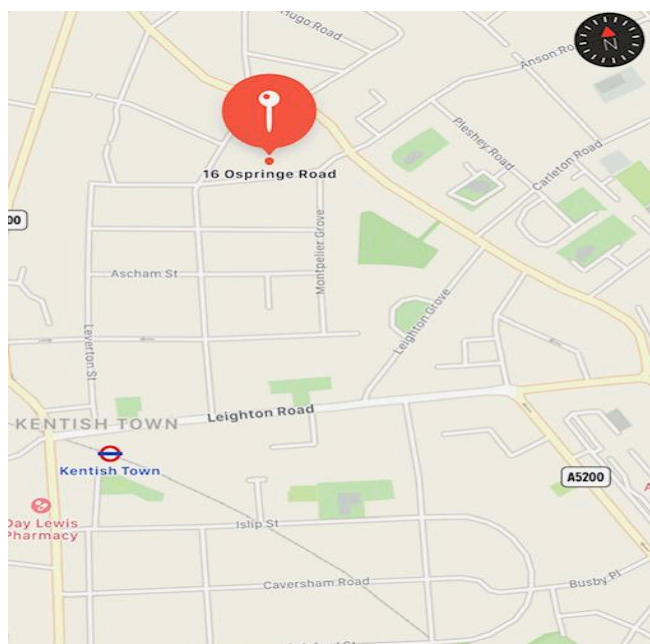

## **2.0 Statutory Protection**

### **2.1 Tree Protection**

A variety of statutory restrictions apply to felling, pruning or damaging of trees with preservation orders (TPO) or within conservation areas (Department for communities and local government, 2014). With exceptions of these restrictions available.

Any trees that require arboricultural works should be checked for any restrictions prior to works commencing.

Applications should be made for trees restricted with a TPO and a six week notification made for works in a conservation area.

Where works are deemed exempt, a submission of a 5 day notification of works should be made in accordance with section 198 (6)(a) of the Town and Country Planning Act 1990.

### **2.2 Wildlife Protection**

As part of the survey tree was inspected from ground level with the use of binoculars for signs of wildlife habitation, in particular birds and bats.

All bats and their roosts are protected by law (The Wildlife and countryside Act 1981 & conservation of Habitats as Species regulations 2010).

Penalties and prosecution for causing damage to bat's or roosts is up to £5,000 per bat and a prison sentence, plus confiscation of vehicles plant and machinery involved.

In the UK all wild birds and their nests are protected by law (The wildlife and Country side Act 1981 & The Countryside Act 2000).

The presence of Bats/roosts or birds nesting will be noted within the survey, where possible all works should be carried out to avoid the bird nesting season.

Prior to any tree works, a visual inspection should be carried out by a qualified person to ensure that there is no loss of protected wildlife habitat.

### 3.0 Methodology

The individual trees were assessed using Claus Mattheck's methods as stated in his guide to visual tree assessment, with a copy of the updated version at hand for instant reference.

The following data was collected for each tree;

- Species (common name)
- Height
- Age
- DBH
- Crown spread in each direction
- Condition
- Comments
- Action
- Priority

Each tree was given a sequential identification number and were plotted on the accompanying map.

#### 3.1 Height

The height was measured using a clinometer and is expressed in metres (to the nearest metre)

#### 3.2 Age

The age of each tree is expressed using the following terms:

- Y            Young
- SM         Semi-mature
- EM         Early-mature
- M           Mature
- OM         Over-mature

#### 3.3 DBH

The diameter of the trees' main stems was measured at breast height and is expressed in centimetres.



### 3.4 Condition

The overall condition of the trees was assessed with regards to its vigour, stem condition, and crown form, and is expressed using the following terms:

- P (Poor)
- F (Fair)
- G (Good)
- D (DEAD)

### 3.5 Distance from property

This measurement is expressed in metres and was used to evaluate current risk and future risk of subsidence or damage to property from roots.

### 3.6 Comments

Any signs of subsidence, hazards, defects or signs of disease observed were recorded.

### 3.7 Action

An action was recommended for each tree to alleviate any hazards/defects identified in the comments section of the data collected.

### 3.8 Priority

The priority for each action required was based on individual tree locations (e.g. near roads, footpaths or buildings) and the severity of the hazards identified in the comments section.

Recommended actions should be undertaken within the following time restraints from the date of the report;

**High (H)** - as soon as possible within a 3 month limitation.

**Medium (M)** - within 12 months.

**Low (L)** - if desirable and/or as part of a long term management plan.

A prioritised work schedule is located in the appendix section of this report along with all accompanying maps, and any supporting photographs.



## 4.0 Tree Survey Schedule

Tree No.	Species	DBH Cm/m	Height	Age	Crown spread N/S/E/W	Condition	Distance from property	Comments	Action	R.P.A
T1	Sycamore	170cm	9m	M	3,2,3,2m	fair	5m	Care to be taken when excavating near tree RPA. Ground protection Tree has a section of exposed deadwood At base with good healthy compartmentalized inclusion	No action	3m2

### 4.1 Site description

I carried out an accompanied site visit on 20/04/21 . The weather on the day was clear. Site is neat and tidy and free from ground cover.

### 4.2 Soil assessment

Heavy clay with loamy sand and silt.



## 5.0 Data Analysis

### 5.1 Conclusion

The Arboricultural implications with regards this development and the trees in surrounding properties are T1 sycamore with a root protection area of 3m<sup>2</sup> from the stem covering the diameter of the canopy. I have observed this trees RPA having low potential impact on the proposed garden room. I have calculated that the RPA miutely impacts the new proposed development. As such I recommend a pile to be used as footing only in the RPA area. The table for the measurement calculation can be found in the appendix of this report. It is possible that some roots extend into this area. As such care should be taken when excavation for the garden room takes place. If any major roots are found a new pile hole should be sought.

The RPA of this tree is encroached upon by the proposed extension but not more than 15% as such, care should be taken when excavation to limit the pruning of any roots. If roots are to be pruned a qualified Arborist should be onsite to oversee this work.

I have added several conditions that should be followed.

No building operations, site preparation or the delivery of materials to the site other than internal works shall commence until a tree protection strategy, including a tree protection plan and arboricultural method statement (in accordance with the BS 5837:2012 standard), have been submitted to and approved in writing by the Local Planning Authority. The protection measures recommended in the approved tree protection strategy shall be implemented prior to the commencement of building operations, site preparation or delivery materials and remain in position until the practical completion of the development.

Reason: To safeguard trees and the character of the area. A pre-commencement condition is necessary in order to ensure that potential harm is minimised before development reaches an advanced stage.

No development, demolition, clearance or preparatory operations including excavation with the exception of internal works, shall commence within the root protection areas shown on the Tree Protection Plan approved in relation to Conditions.

Reason: To ensure surfacing works within root protection areas do not have an adverse impact on the nearby retained natural features.

No tree works (including pruning and / or felling) shall be undertaken in connection with the development hereby approved until a detailed scheme of facilitation tree works has been submitted to, and approved in writing by the Local Planning Authority. The tree works shall be undertaken in accordance with the approved details.



Reason: To ensure any required tree works do not cause damage to the retained trees and to protect and to enhance the visual amenity, character and appearance of the site.

## 6.0 Arboricultural method statement

### 6.1 Generally

Development can harm trees if not carried out carefully. Tree's crowns and trunks can be damaged by machinery or scorched by fire or chemicals. Trees roots can be asphyxiated and die if the rooting zone becomes compacted and the soil structure damaged. This can happen very easily, particularly on clay soils, even with the passage of light vehicles. Tree roots can be damaged by raising or lowering the ground level. In some cases it can take several years for the damage to become apparent. This report details how the approved development will take place whilst ensuring that the trees shown for retention can be protected, and for the protection of the soil in the areas for new planting.

**6.1.1 Fires:** Fires on site should be avoided if possible. If unavoidable, they should be situated far enough so that there is no risk of damage to the trees, taking into consideration the wind direction.

**6.1.2 Site and fuel storage,** cement mixing and washing points: All site storage areas, cement mixing and washing points for equipment and vehicles and fuel storage areas should be outside root protection areas unless otherwise agreed with the Local Planning Authority. No discharge of potential contaminants should occur within 10m of a retained tree stem or where there is a risk of run off into Root Protection Areas.

**6.1.3 Temporary buildings for site use:** Site cabins, trailers and other temporary buildings can sometimes be used in root protection area if consent is agreed by the local planning authority. This can be very useful if there is a robust existing hard surfacing in place. The method for installing the buildings, and assessment of whether ground protection is needed is to be agreed with the Arboriculturist and specified prior to installation.

**6.1.4 Protection of tree canopies:** Piling rigs and cranes are often used close to trees. Work must be carefully planned so that there is sufficient room to avoid hitting the canopy during transportation or operation. Arboricultural supervision may be required, however it is the responsibility of the contractor to assess and plan the work. Any access facilitation pruning required is detailed in the tree surgery schedule.

## 7.0 Glossary of Terms & Definitions

**Amenity-** the pleasantness or attractiveness of a place.

**Asymmetrical crown-** unbalanced, one-sided.

**Cavity-** hole within a stem/branch of a tree, caused by decay or damage.



**Crotch/fork/ union** - region formed by a junction of two branches, or stem and branch.

**Crown**- overall branch and foliage cover.

**Deadwood**- dead branches within the crown of a tree. <30mm diameter classified as minor deadwood, >30mm major deadwood.

**Dieback**- ends of branches with no leaf coverage, sign of decline.

**Early-mature**- a tree that has not reached maturity but is deemed to be 2/3 the way through its life expectancy.

**Epicormic**- shoot growth from dormant or adventitious buds on main stems or branches.

**Fastigate**- Upright crown form.

**Good form**- good crown shape and size expectant of specific species characteristics.

**Over-mature**- a tree that has exceeded its life expectancy.

**Mature**- a tree that has reached the final third of its life stage.

**Stem**- above ground structure that supports the branches of a tree.

**Vigour**- physical strength and health of a tree

## Appendix







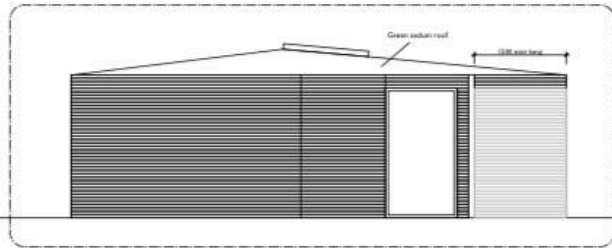

West Elevation

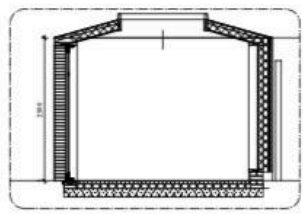

Section A

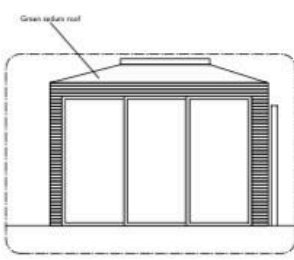

South Elevation

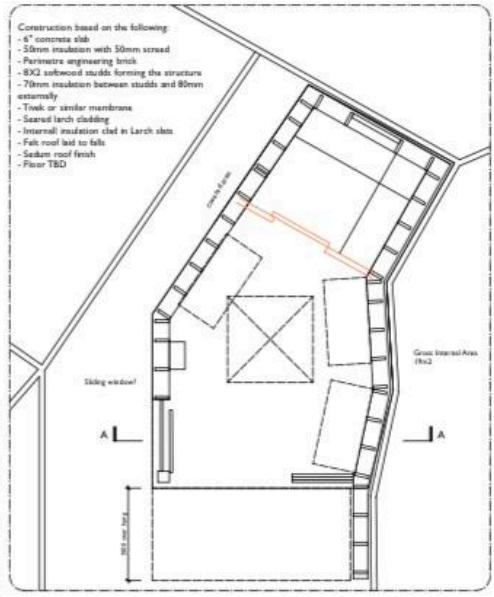

Ground Floor Plan

- Construction based on the following
- 6" concrete slab
  - 50mm insulation with 50mm screed
  - Perimeter engineering brick
  - 600 softwood studs forming the structure
  - 70mm insulation between studs and 80mm externally
  - Treck or similar membrane
  - Sealed larch cladding
  - Internal insulation clad in Larch slat
  - Fall roof lead to falls
  - Sedum roof finish
  - Floor TBD

**MARTINS CAMISULI** Unit 1A Clarendon Road, London, N9 9LH, Tel: 020 7267 86 22  
**JOB TITLE:** 16A Osprings road London  
**DRWG TITLE:** Proposed Garden Structure  
**DRWG NO:** PNC201021\_02  
**SCALE:** 1:50 @ A3  
**DATE:** Feb 2021  
**ALL DIMENSIONS INDICATED ON THIS DRAWING ARE SUBJECT TO ALTERATIONS ONCE ON SITE. CONFIRM ALL DIMENSION ON SITE PRIOR TO ORDERING AND CONSTRUCTION.**





CONSTRUCTION EXCLUSION ZONE - NO ACCESS

Figure 2 Default specification for protective barrier

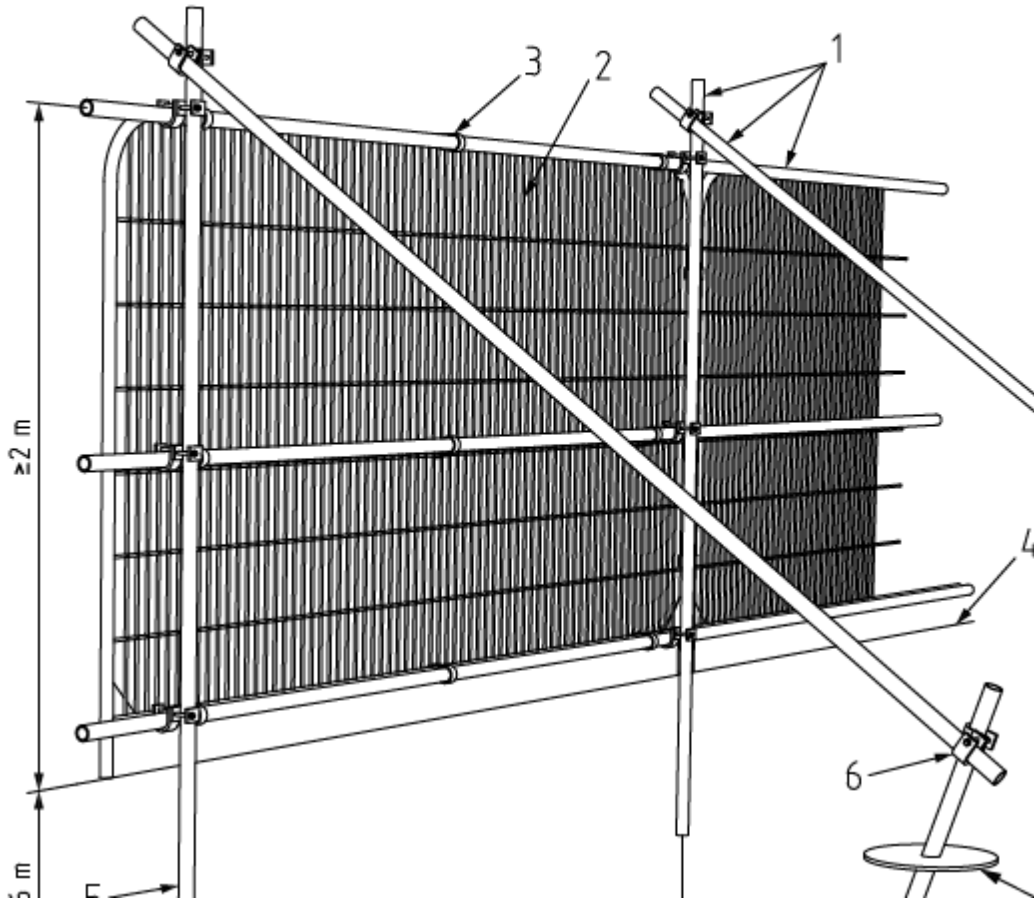

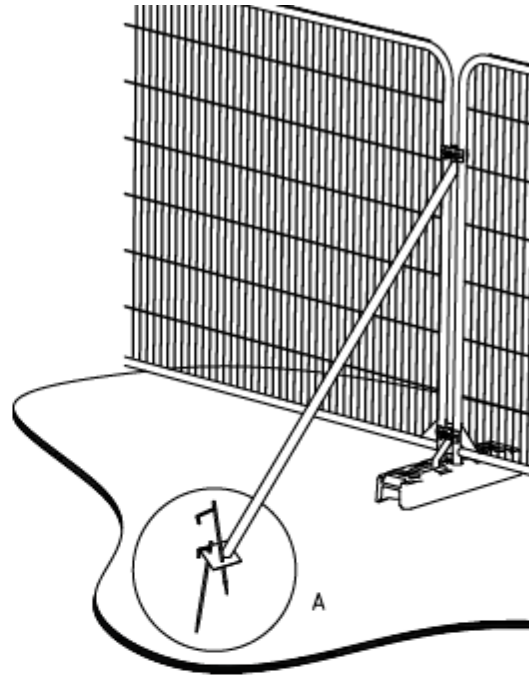
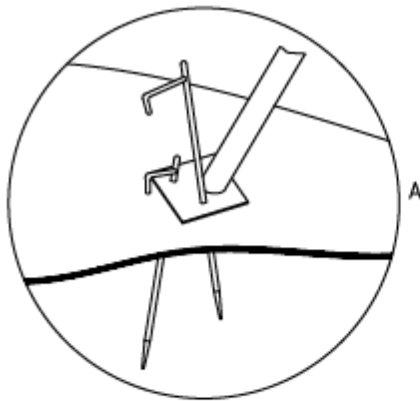

Stabilizer strut with base plate secured with ground pins

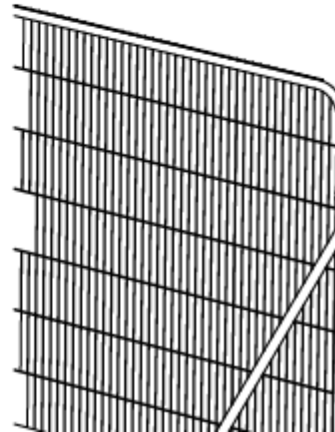
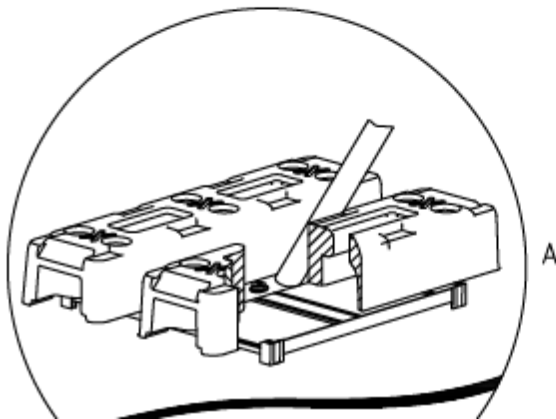

Link for appropriate ground protection although many exist [www.geosyn.co.uk](http://www.geosyn.co.uk)





(normative)

## Root protection area

The RPAs given in Table D.1 should be used for single stem trees and the equivalent resultant combined stem diameter for multi-stemmed trees.



Single stem diameter mm	Radius of nominal circle m	RPA m <sup>2</sup>	Single stem diameter mm	Radius of nominal circle m	RPA m <sup>2</sup>
75	0.90	3	675	8.10	206
100	1.20	5	700	8.40	222
125	1.50	7	725	8.70	238
150	1.80	10	750	9.00	255
175	2.10	14	775	9.30	272
200	2.40	18	800	9.60	290
225	2.70	23	825	9.90	308
250	3.00	28	850	10.20	327
275	3.30	34	875	10.50	346
300	3.60	41	900	10.80	366
325	3.90	48	925	11.10	387
350	4.20	55	950	11.40	408
375	4.50	64	975	11.70	430
400	4.80	72	1 000	12.00	452
425	5.10	81	1 025	12.30	475
450	5.40	92	1 050	12.60	499
475	5.70	102	1 075	12.90	519
500	6.00	113	1 100	13.20	547
525	6.30	124	1 125	13.50	573
550	6.60	137	1 150	13.80	598
575	6.90	150	1 175	14.10	625
600	7.20	163	1 200	14.40	652
625	7.50	177	1 225	14.70	679
650	7.80	191	1 250+	15.00	707

Table D.1 Root protection areas

*NOTE These figures are derived from the calculations described in 4.6.*

**BS 5837:2012  
STANDARD**

40 •

**BRITISH**

This report has been carried out and compiled by

Liam McGough FdSc Arb M ArborA

36 Queens Rd, London, N11 2QU

07738004625/020 8013 1187