

Internal Room Elevation
Scale: 1:10

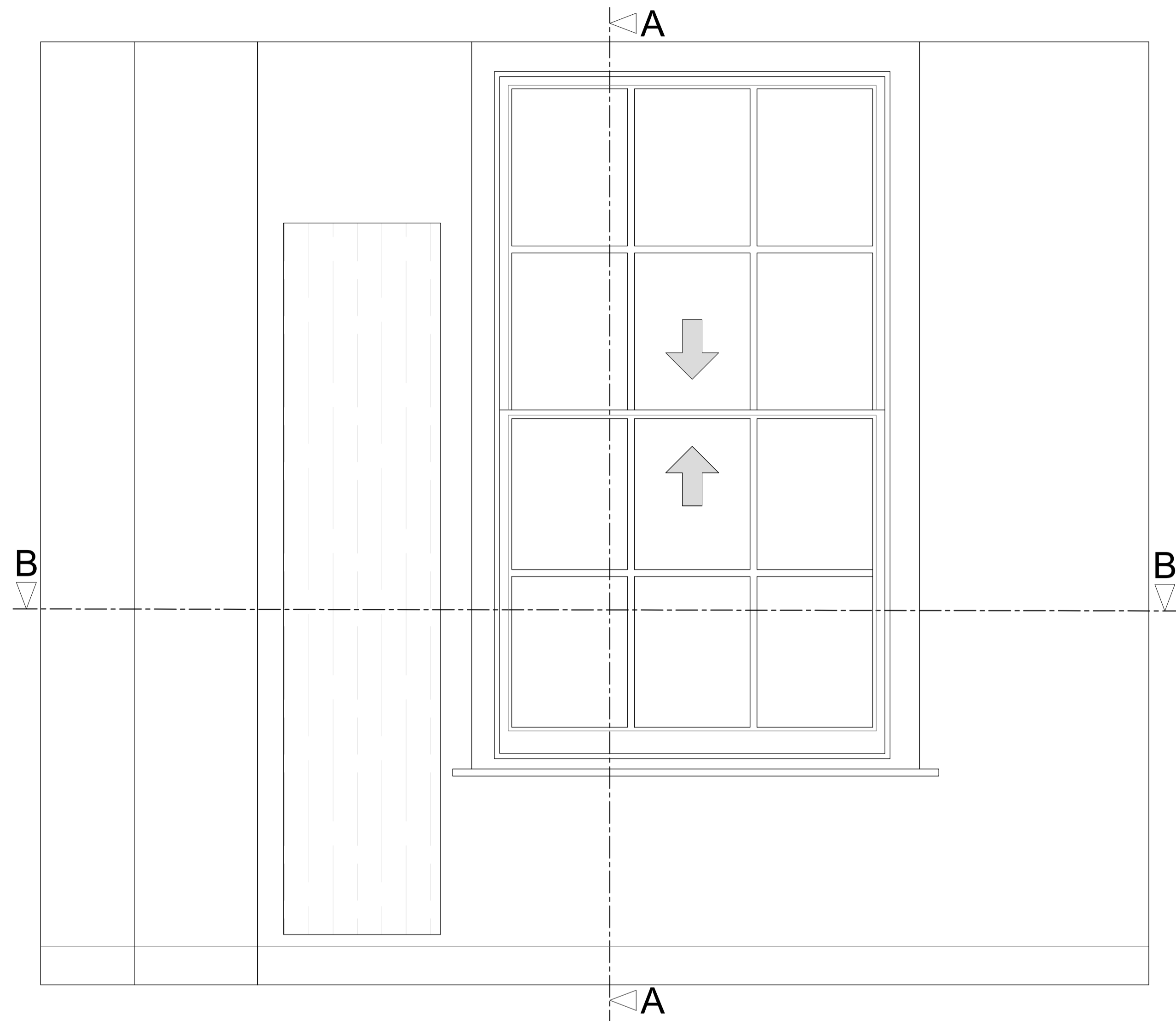

Section A-A through External Wall
Scale: 1:10

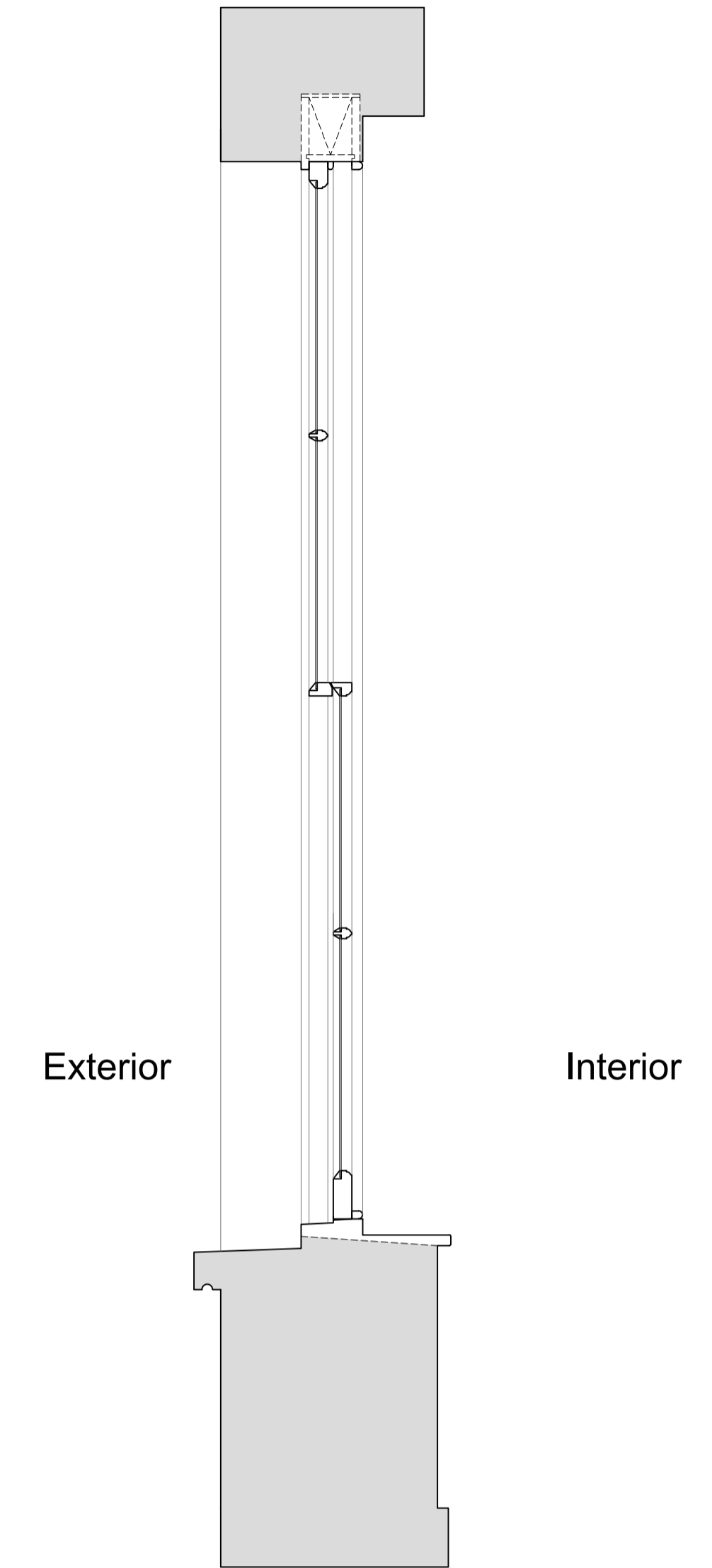

Plan Section B-B
Scale: 1:10

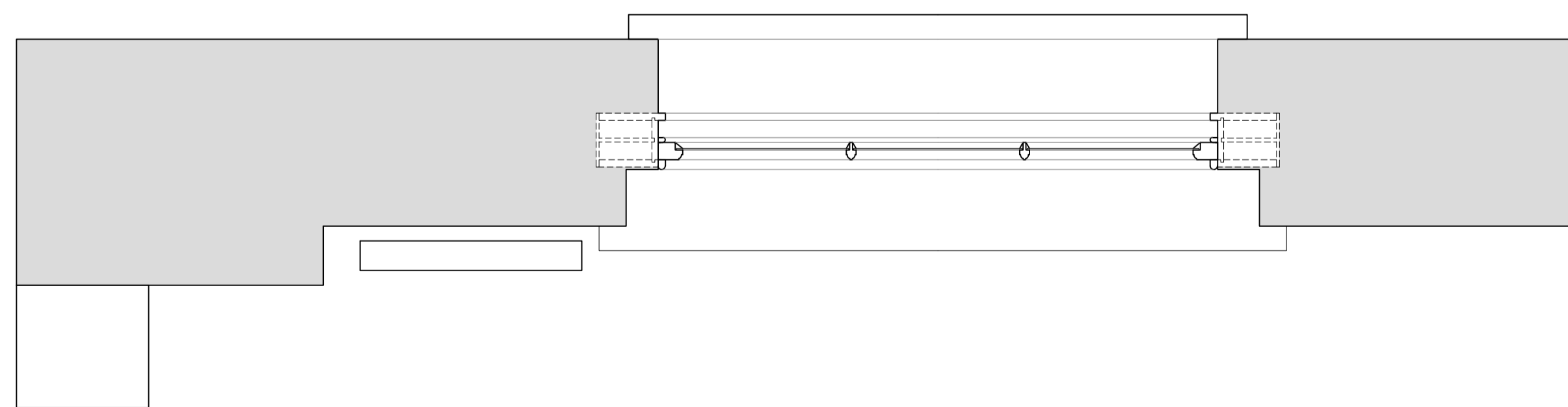

Revision	Date	Assessment
1.0	11-05-2021	Issued for listed building consent application

Do not reproduce this drawing without written permission
All dimensions are in millimetres unless stated otherwise

HS2
High Speed (HS2) Limited
1st-3rd Floor
The Podium
1 Eversholt Street
London NW1 2DN

COSTAIN SKANSKA
Costain Skanska Joint Venture
9th Floor
The Tower
1 Eversholt Street
London NW1 2DN

Site Address: 190 North Gower Street, London NW1			
Drawing Title: First Floor - Bedroom-302:EXISTING Window Joinery Details - Sheet 1 of 3			
Drawn by: AP & OB	Drawn by: AP	Checked by: OB	Presentation Scale: as shown @ A1
Date: 10-05-2021	Drawing No: WPI P066 NI -190 NGS-EX-FF-J-03	Revision: 1.0	

Drawing Not For Construction

Internal Room Elevation with Secondary Glazing Installed
Scale: 1:10

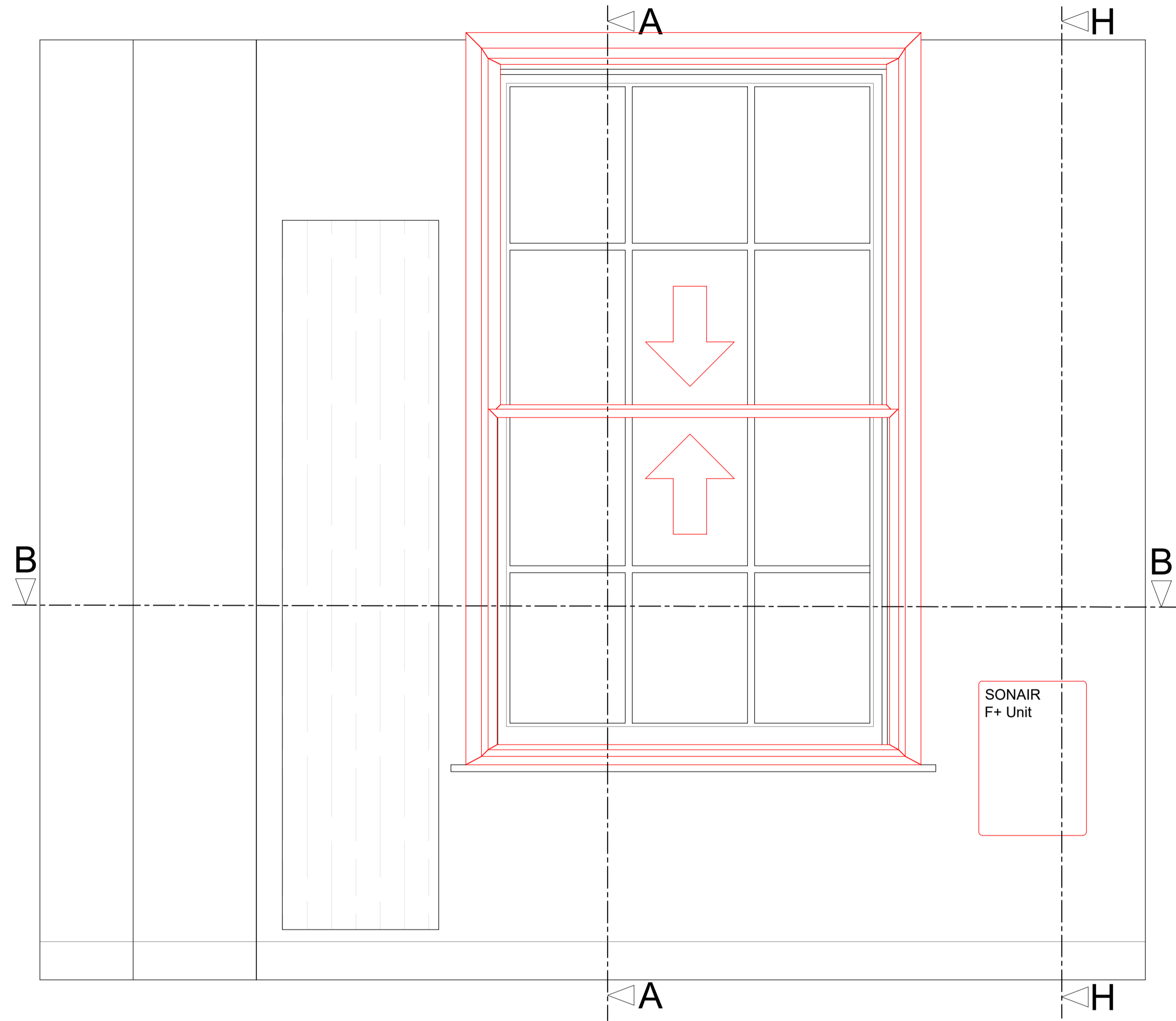

Section A-A through External Wall with Secondary Glazing Installed
Scale: 1:10

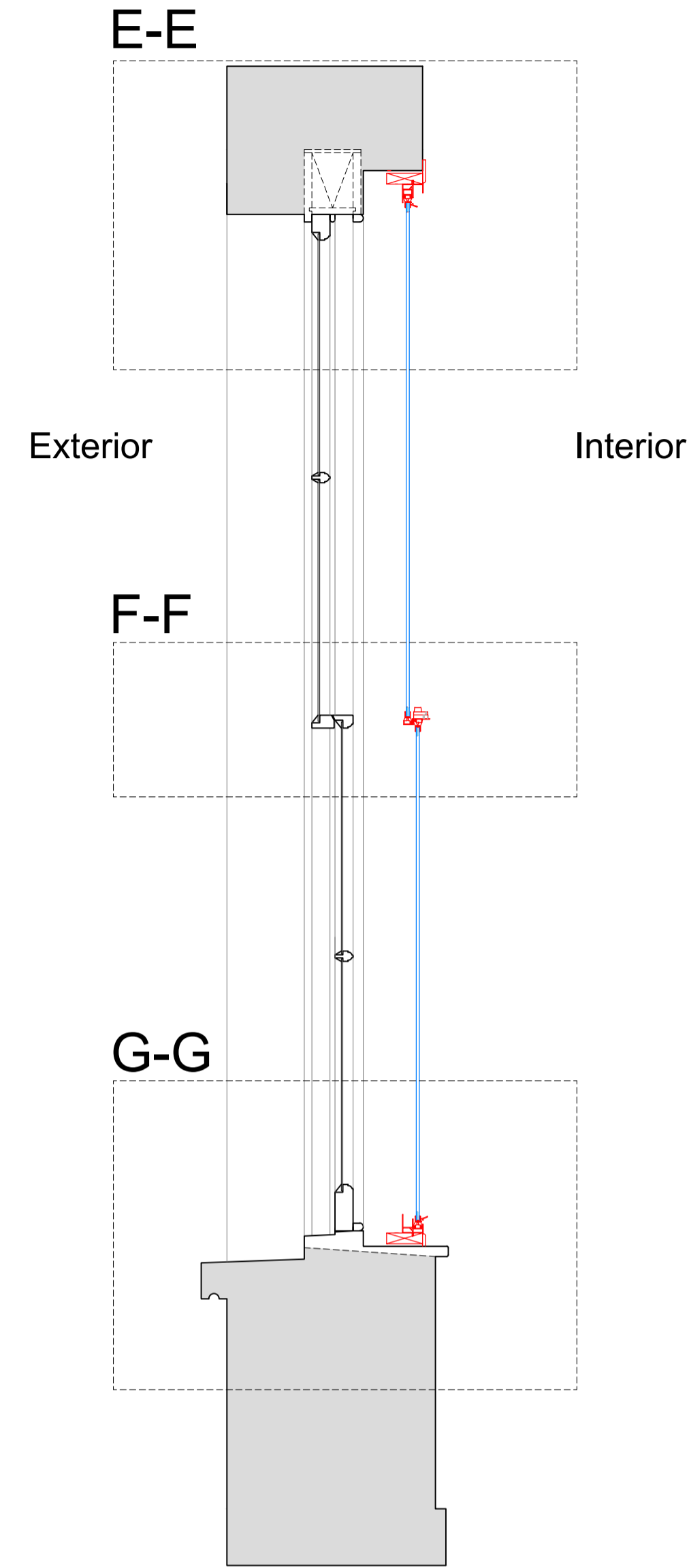

Section H-H through External Wall with Mechanical Ventilation Installed
Scale: 1:10

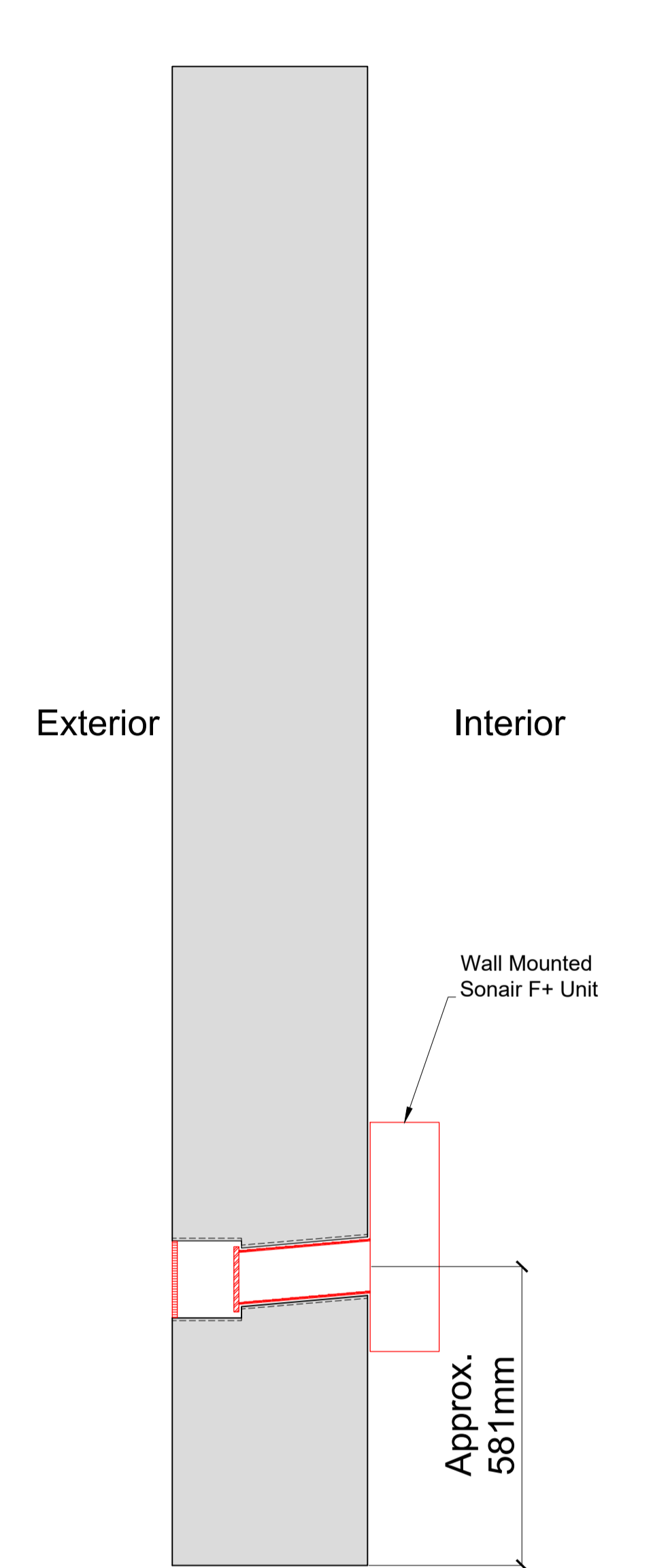

Plan Section B-B with Secondary Glazing Installed
Scale: 1:10

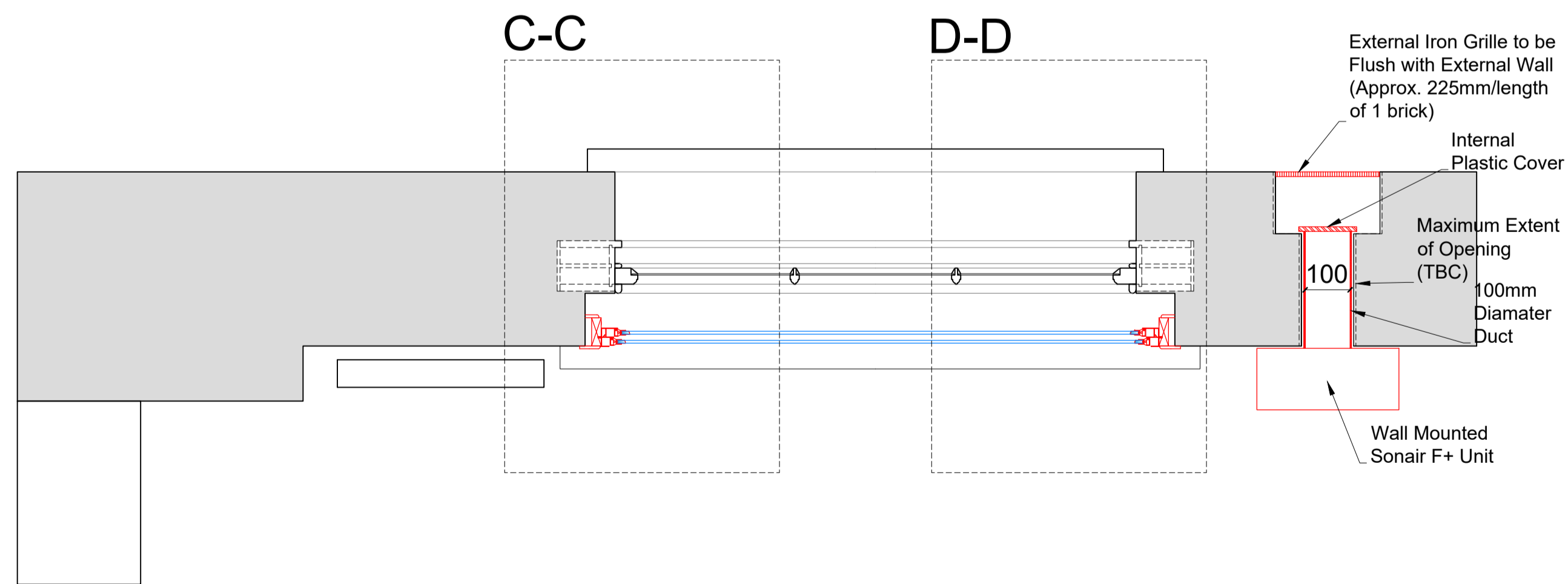

Detail of Sonair Unit
Scale: 1:5

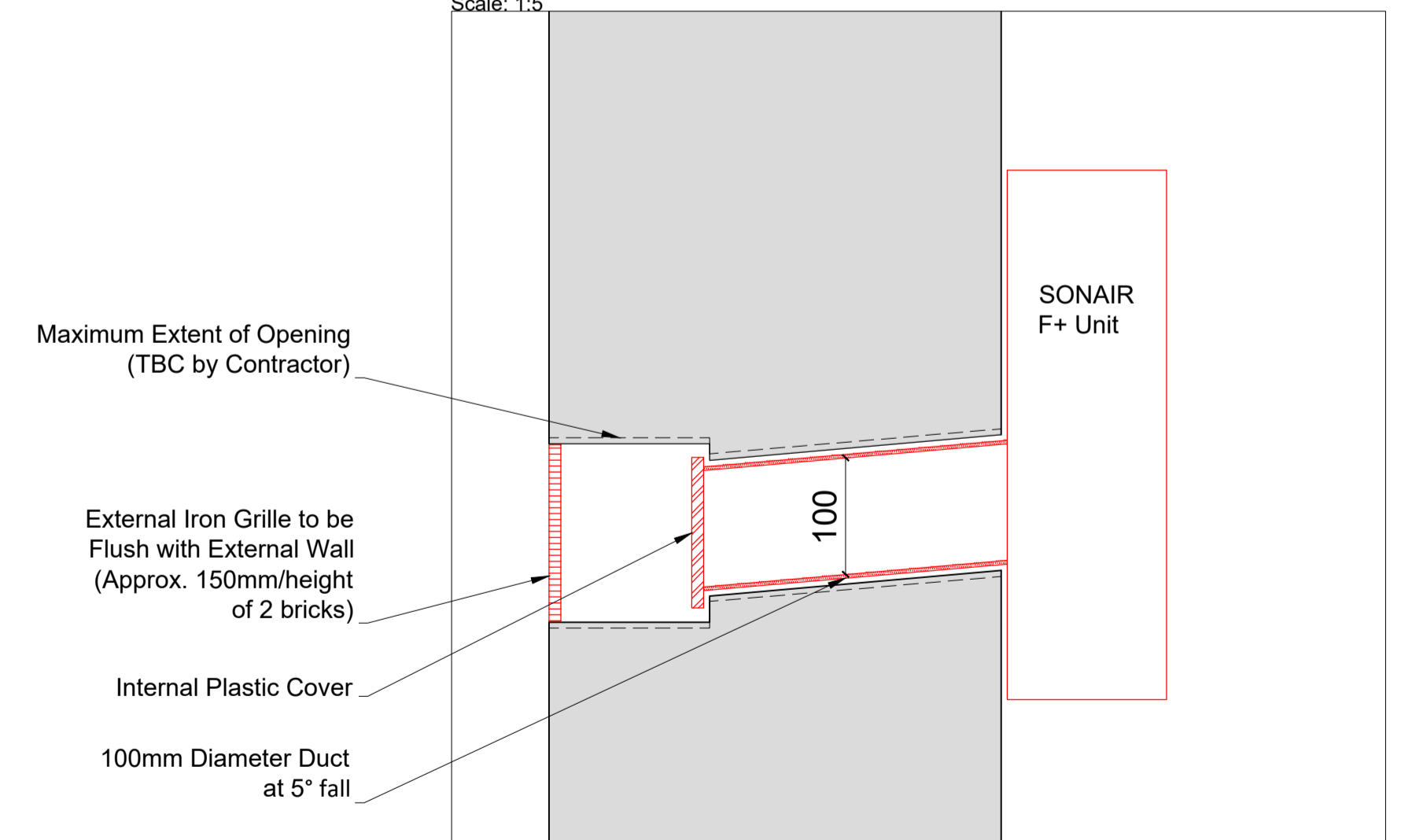

SECONDARY GLAZING SHOWN IN RED FOR VISUAL CLARITY ONLY

Revision	Date	Assessment
1.0	11-05-2021	Issued for listed building consent application

Do not reproduce this drawing without written permission
All dimensions are in millimetres unless stated otherwise

HS2

High Speed (HS2) Limited
1st-3rd Floor
The Podium
1 Eversholt Street
London NW1 2DN

COSTAIN SKANSKA

Costain Skanska Joint Venture
9th Floor
The Tower
1 Eversholt Street
London NW1 2DN

Site Address:
190 North Gower Street, London NW1

Drawing Title:
First Floor - Bedroom-302:PROPOSED Secondary Glazing Details - Sheet 2 of 3

Drawn by: AP & OB
Checked by: AP
Presentation Scale: OB
as shown @ A1

Date: 10-05-2021
Drawing No: WPI P066 NI -190 NGS-PR-FF-J-03.1
Revision: 1.0

Drawing Not For Construction

Section C-C
Scale: 1:5 on A1

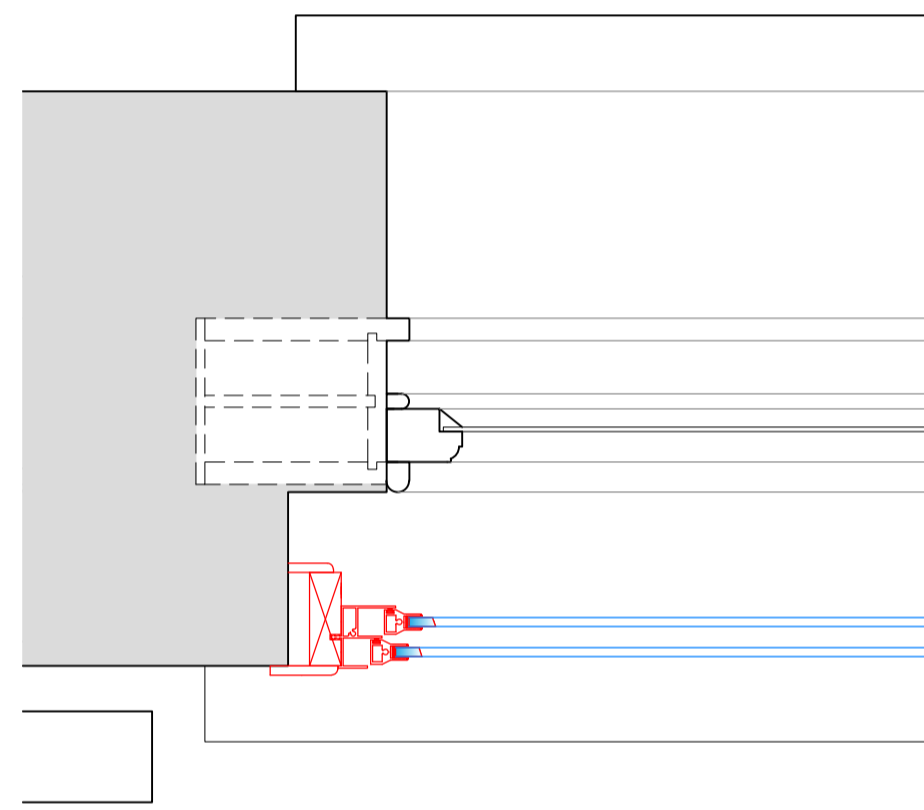

Section D-D
Scale: 1:5 on A1

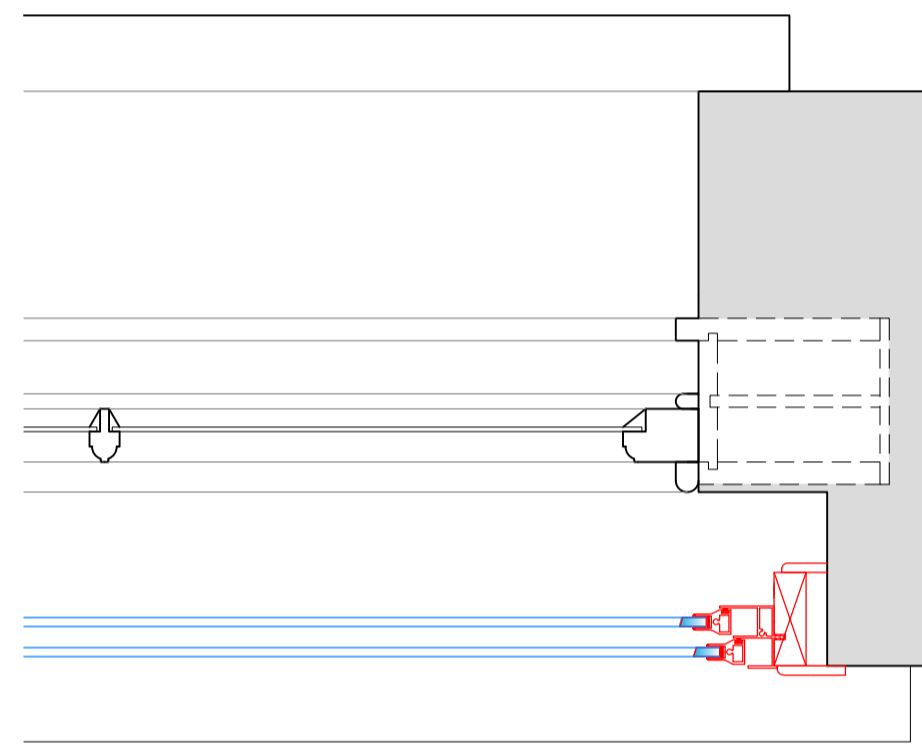

Section E-E
Scale: 1:5 on A1

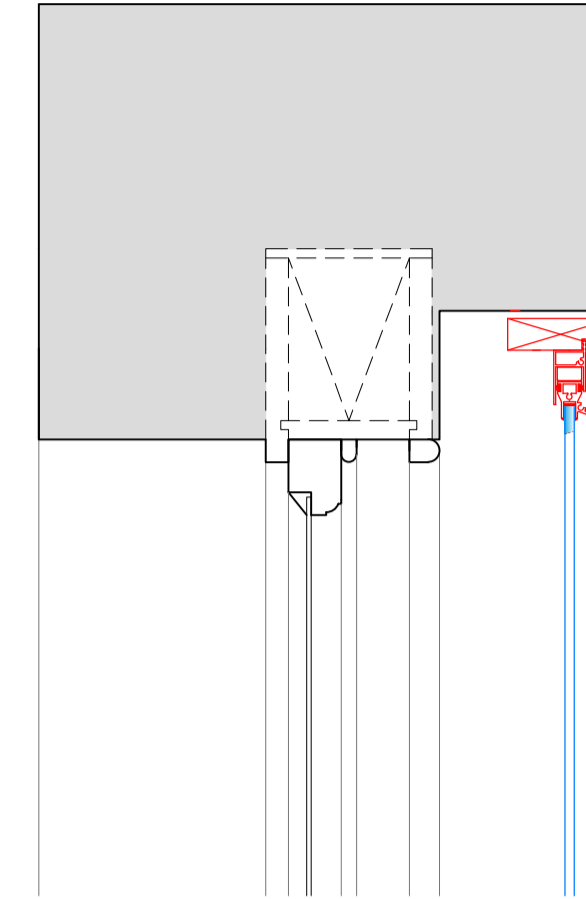

Section F-F
Scale: 1:5 on A1

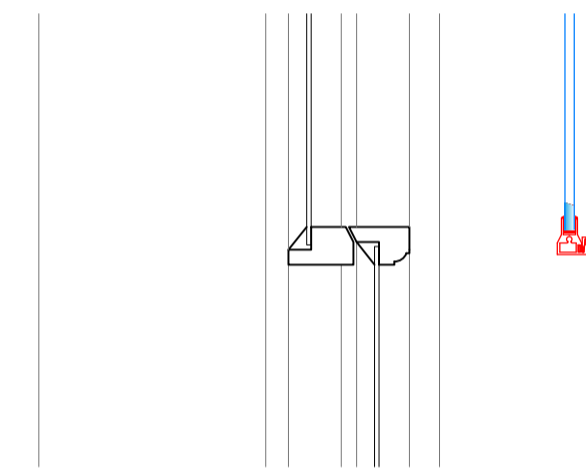

Section G-G
Scale: 1:5 on A1

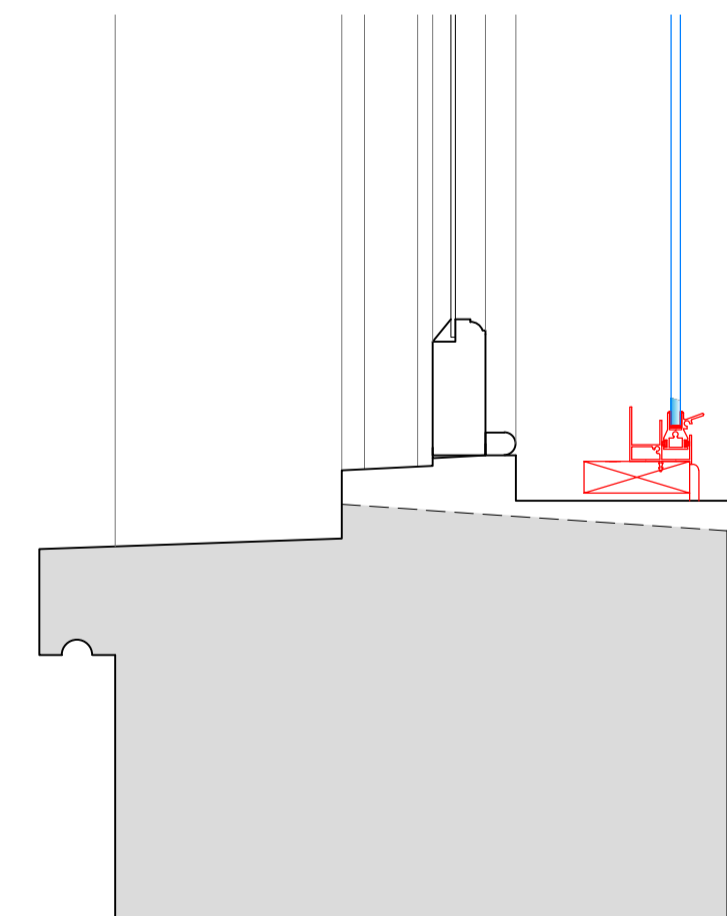

SECONDARY GLAZING SHOWN IN RED FOR VISUAL CLARITY ONLY

Revision	Date	Assessment
1.0	11-05-2021	Issued for listed building consent application

Do not reproduce this drawing without written permission
All dimensions are in millimetres unless stated otherwise

Drawing Not For Construction

HS2

High Speed (HS2) Limited
1st-3rd Floor
The Podium
1 Eversholt Street
London NW1 2DN

COSTAIN SKANSKA

Costain Skanska Joint Venture
9th Floor
The Tower
1 Eversholt Street
London NW1 2DN

Site Address: 190 North Gower Street, London NW1			
Drawing Title: First Floor - Bedroom-302:PROPOSED Secondary Glazing Details - Sheet 3 of 3			
Drawn by: AP & OB	Drawn by: AP	Checked by: OB	Presentation Scale: 1:5 @ A1
Date: 10-05-2021	Drawing No: WPI P066 NI -190 NGS-PR-FF-J-03.2	Revision: 1.0	

Internal Room Elevation

Scale: 1:10

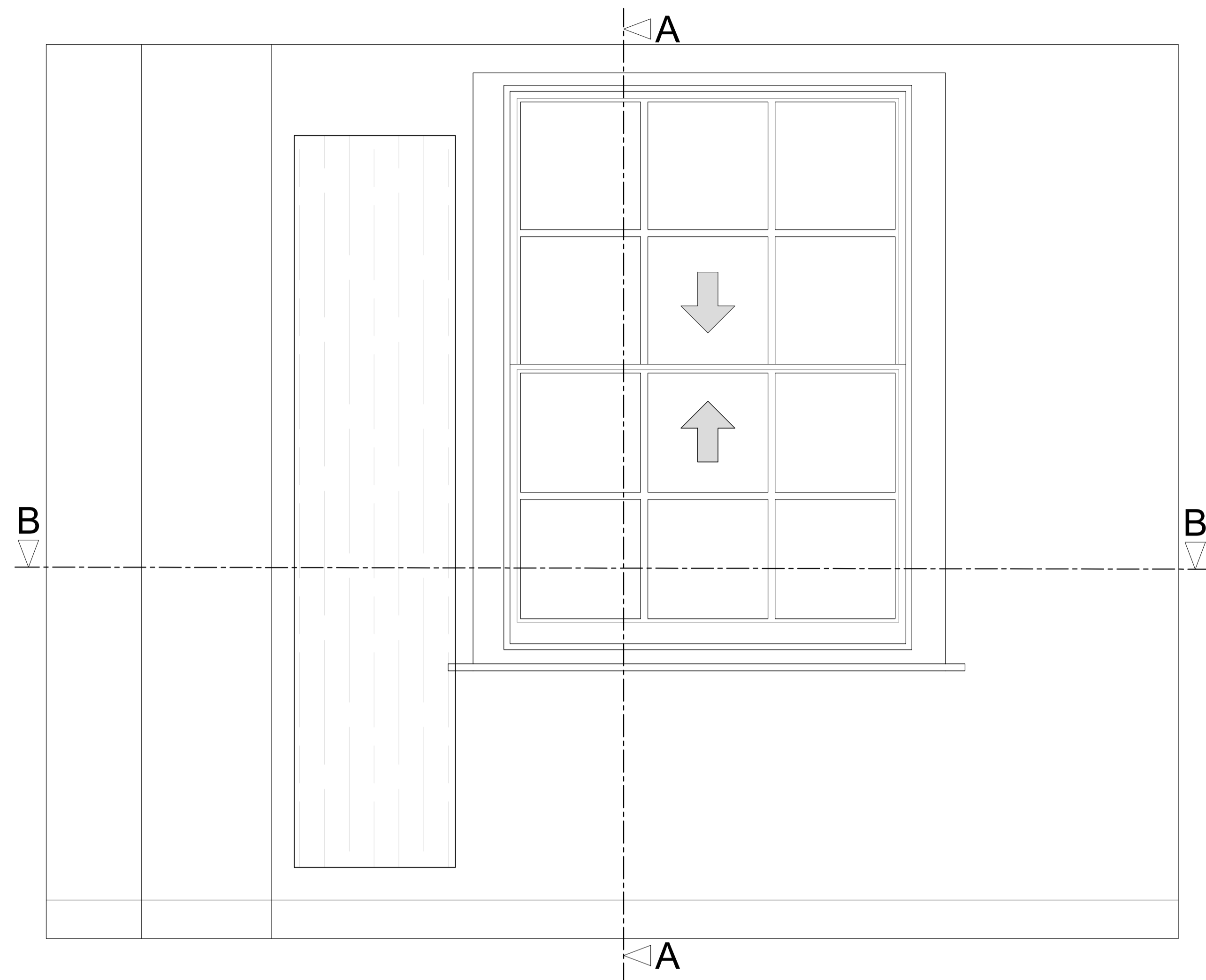

Section A-A through External Wall

Scale: 1:10

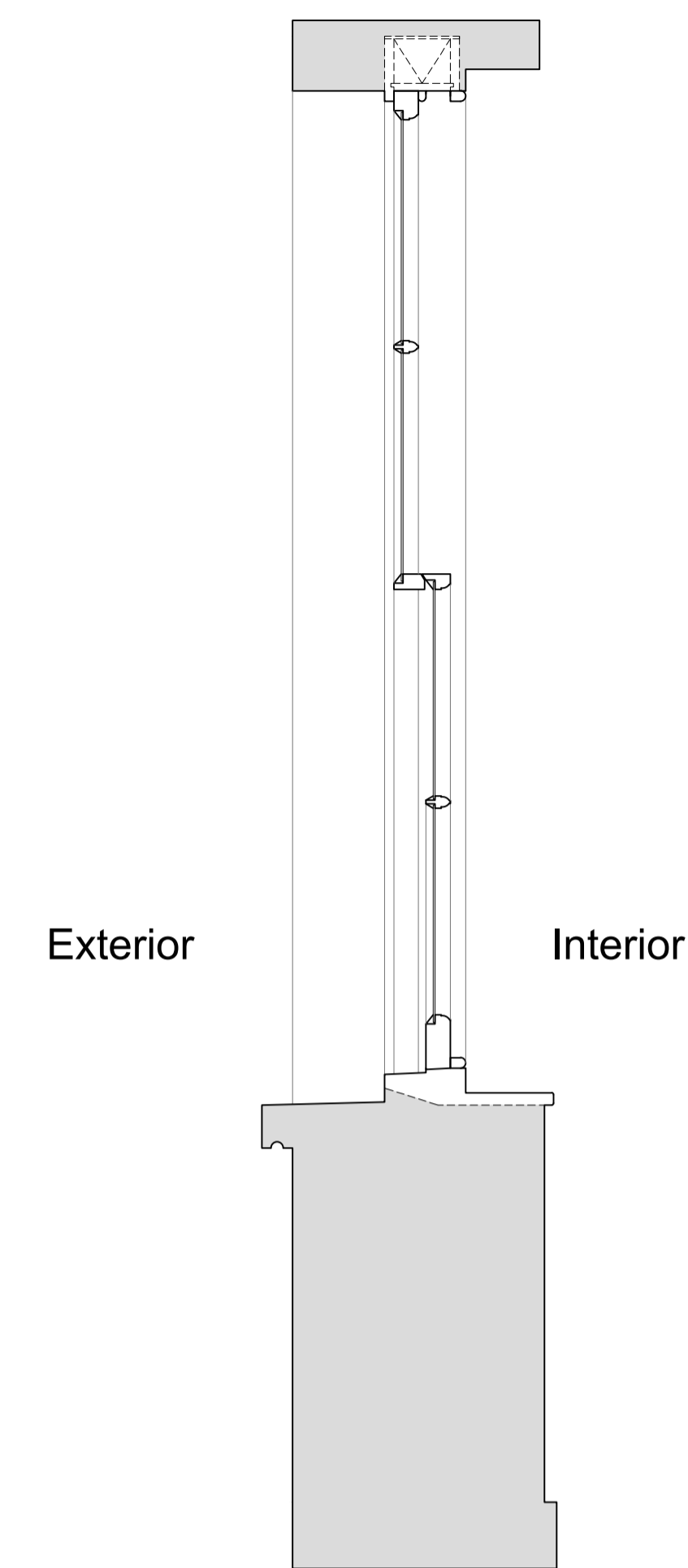

Plan Section B-B

Scale: 1:10

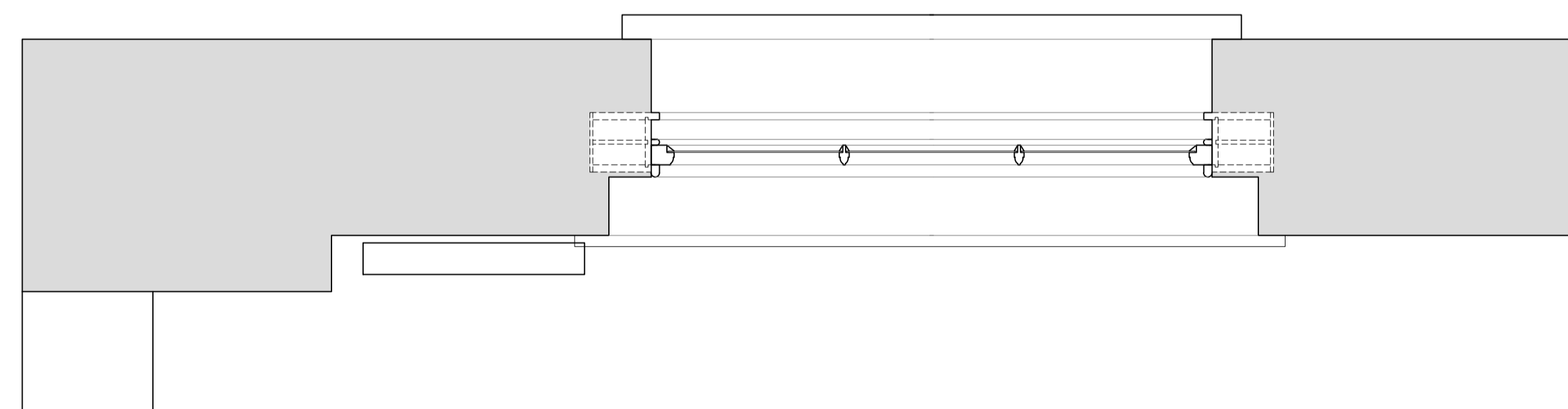

Revision	Date	Assessment
1.0	11-05-2021	Issued for listed building consent application

Do not reproduce this drawing without written permission
All dimensions are in millimetres unless stated otherwise

HS2

High Speed (HS2) Limited
1st-3rd Floor
The Podium
1 Eversholt Street
London NW1 2DN

COSTAIN SKANSKA

Costain Skanska Joint Venture
9th Floor
The Tower
1 Eversholt Street
London NW1 2DN

Site Address:
190 North Gower Street, London NW1

Drawing Title:
Second Floor - Bedroom-402: EXISTING Window Joinery Details - Sheet 1 of 3

Drawn by: AP & OB Drawn by: AP Checked by: OB Presentation Scale: as shown @ A1

Date: 10-05-2021 Drawing No: WPI P066 NI -190 NGS-EX-SF-J-04 Revision: 1.0

Drawing Not For Construction

Internal Room Elevation with Secondary Glazing Installed

Scale: 1:10

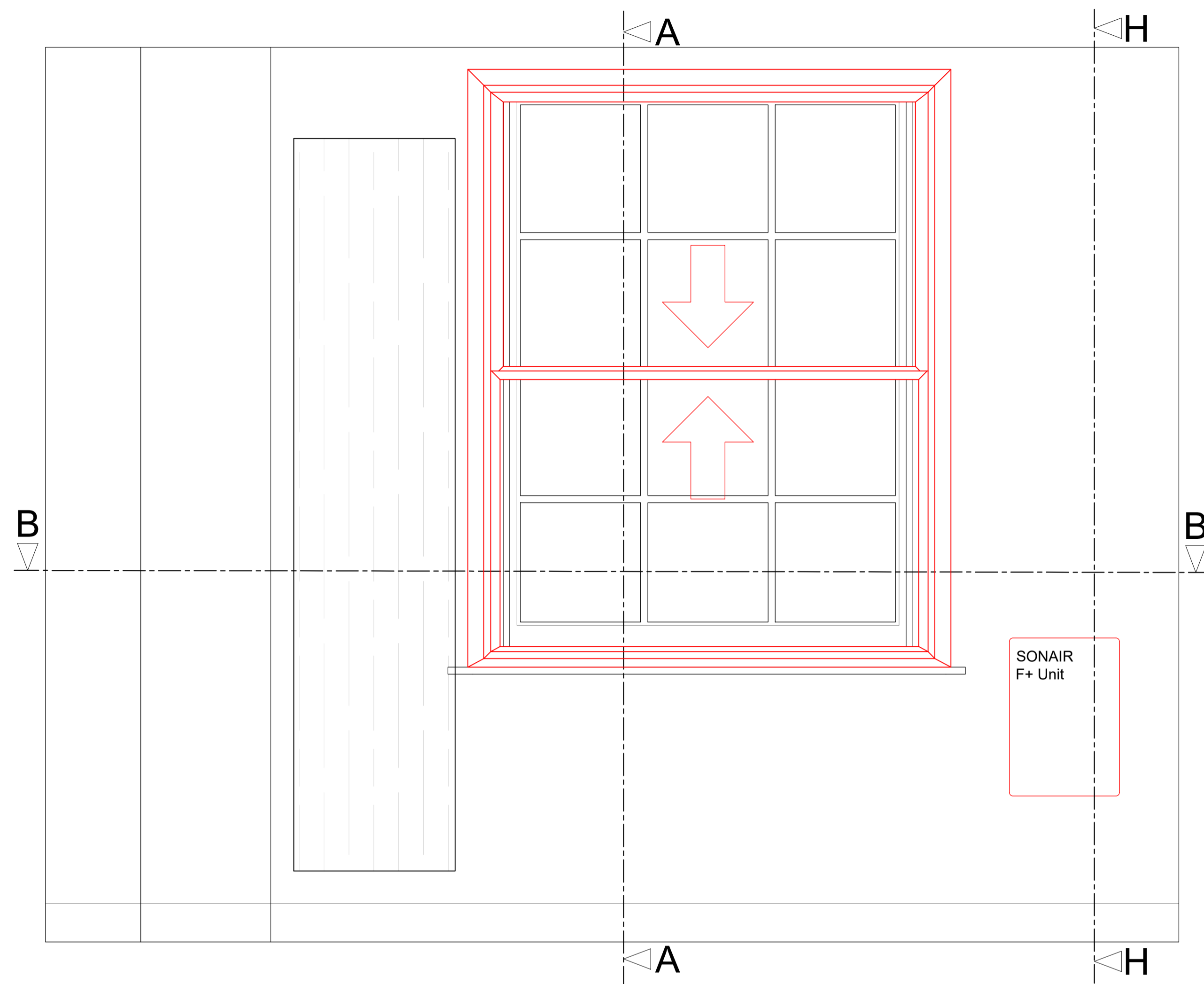

Section A-A through External Wall with Secondary Glazing Installed

Scale: 1:10

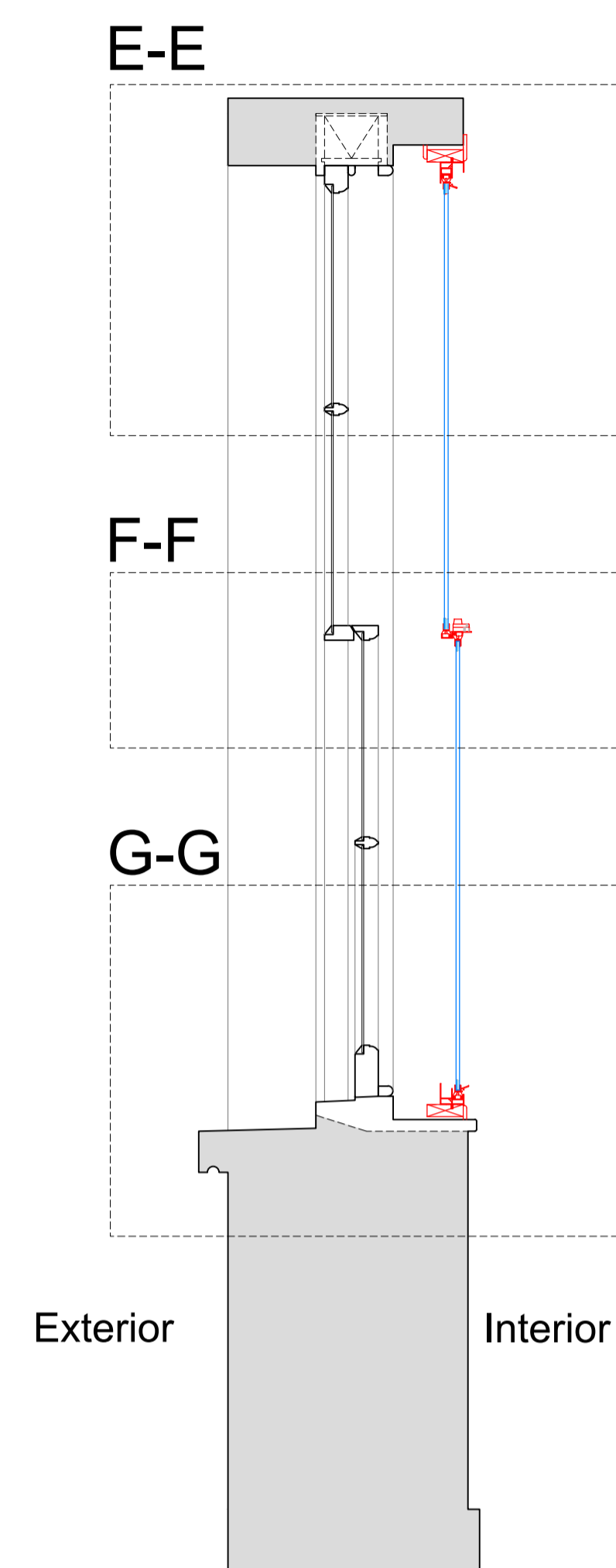

Section H-H through External Wall with Mechanical Ventilation Installed

Scale: 1:10

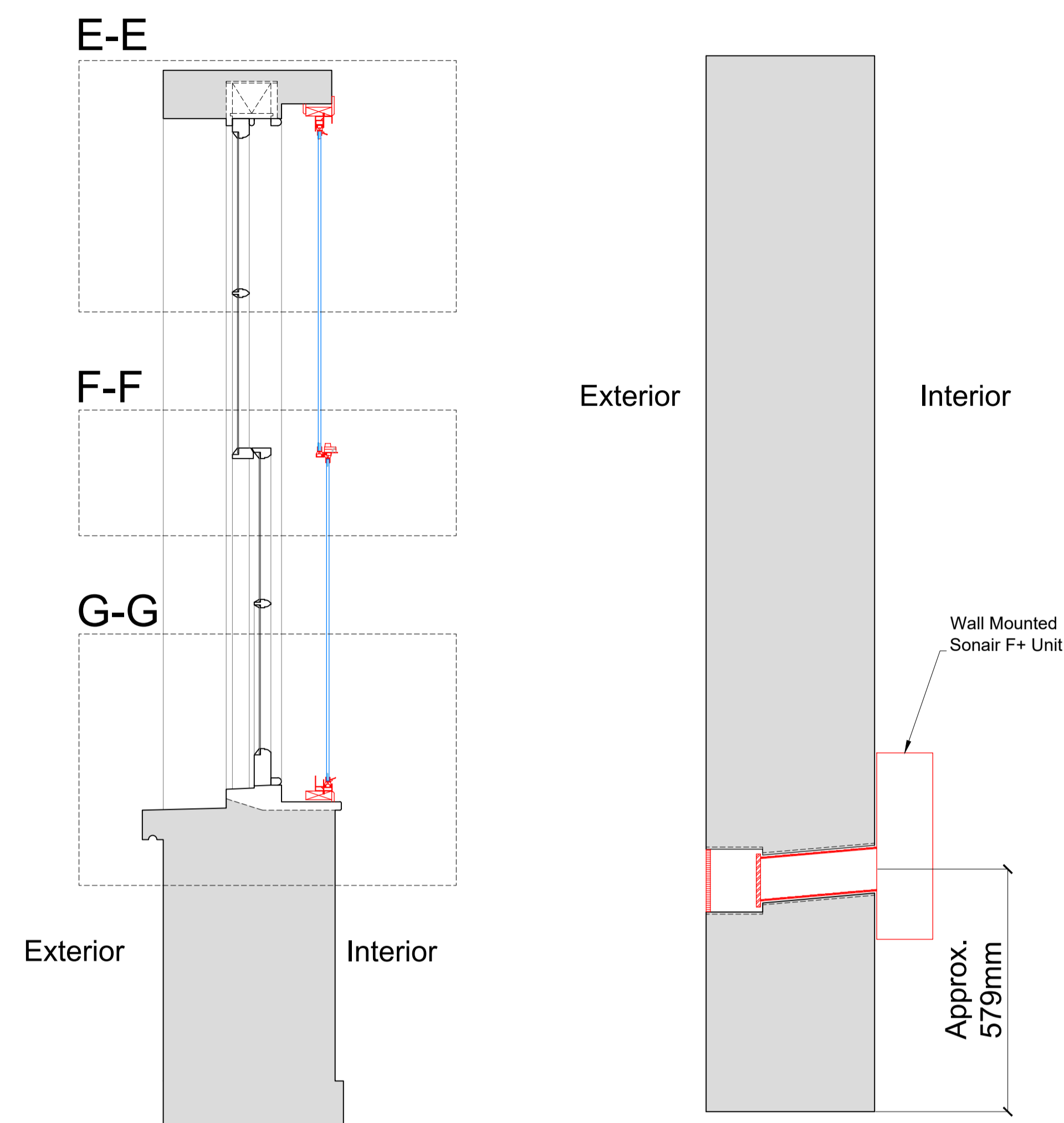

Plan Section B-B with Secondary Glazing Installed

Scale: 1:10

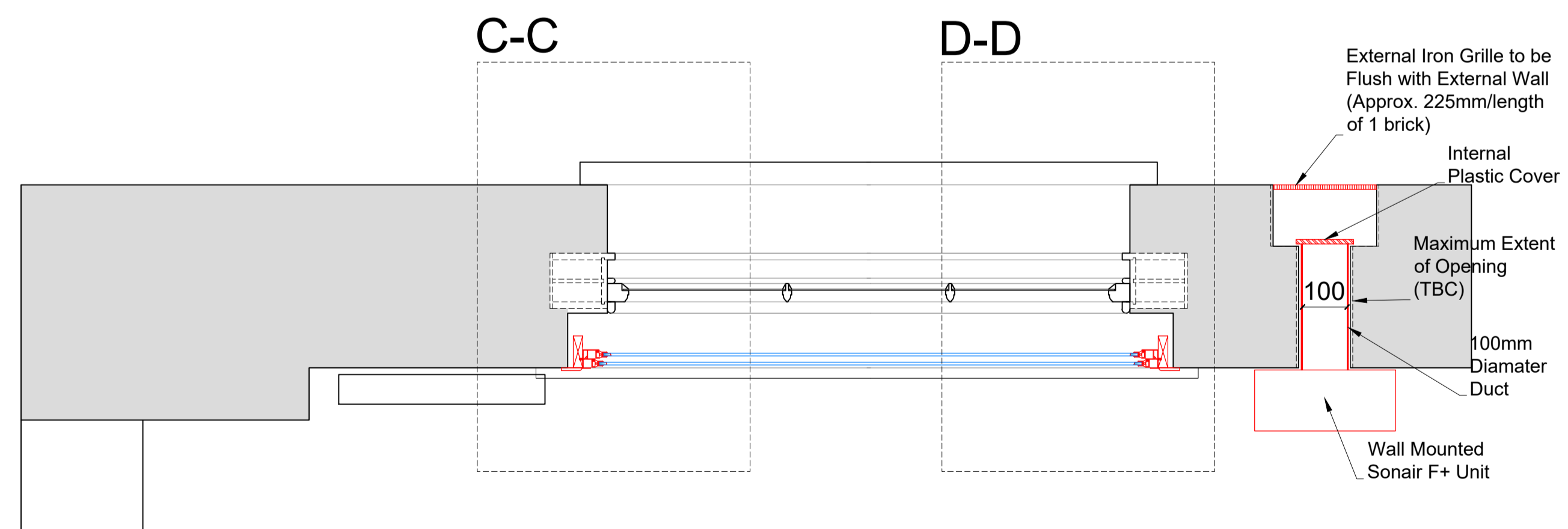

SECONDARY GLAZING SHOWN IN RED FOR VISUAL CLARITY ONLY

Detail of Sonair Unit

Scale: 1:5

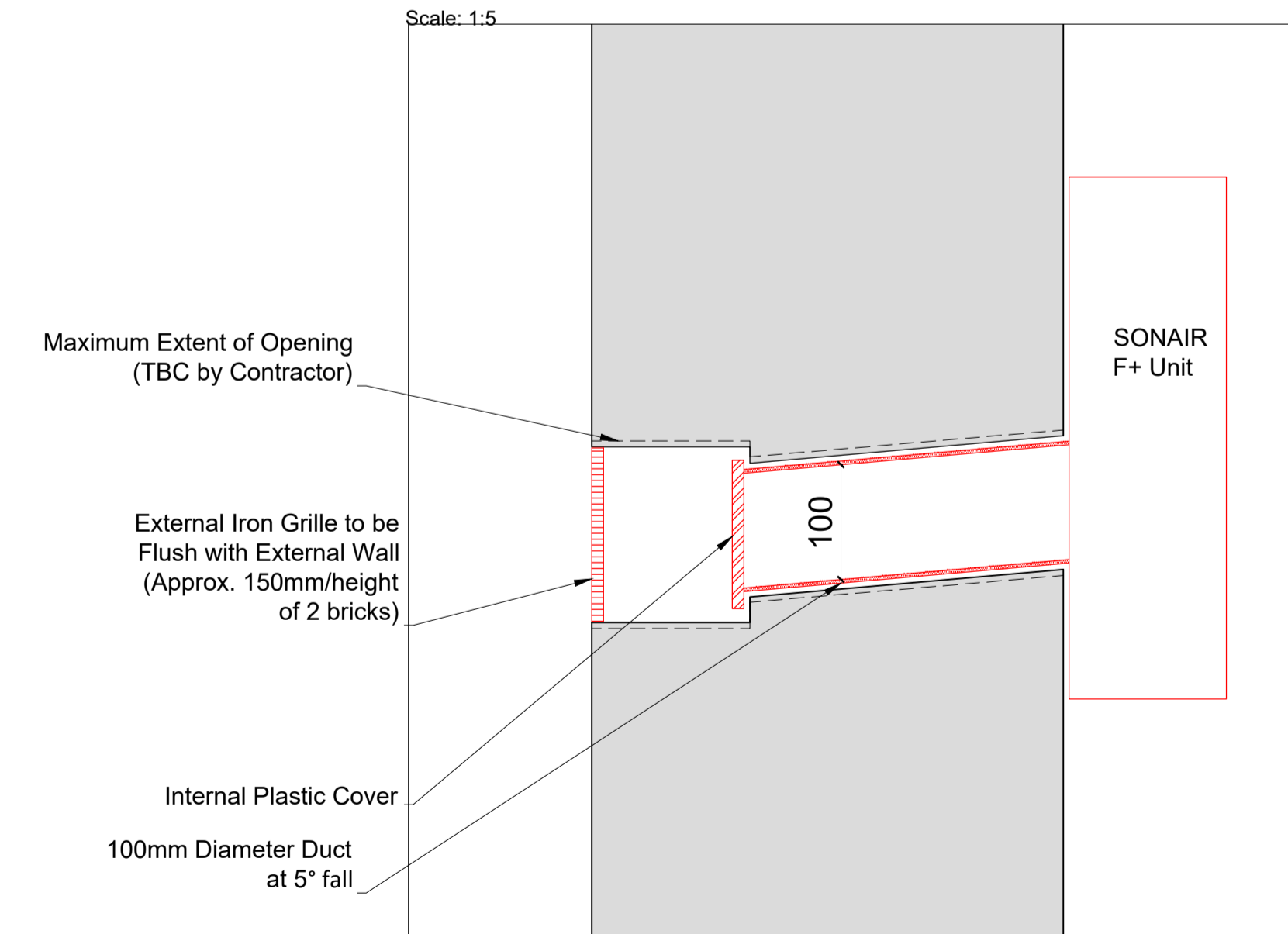

Revision	Date	Amendment
1.0	11-05-2021	Issued for listed building consent application

Do not reproduce this drawing without written permission
All dimensions are in millimetres unless stated otherwise

HS2

High Speed (HS2) Limited
1st-3rd Floor
The Podium
1 Eversholt Street
London NW1 2DN

COSTAIN SKANSKA

Costain Skanska Joint Venture
9th Floor
The Tower
1 Eversholt Street
London NW1 2DN

Site Address: 190 North Gower Street, London NW1			
Drawing Title: Second Floor - Bedroom-402: PROPOSED Secondary Glazing Details - Sheet 2 of 3			
Drawn by: AP & OB	Checked by: OB	Presented by: as shown @ A1	
Date: 10-05-2021	Drawing No: WPI P066 NI -190 NGS-PR-SF-J-04.1	Revision: 1.0	

Drawing Not For Construction

Section C-C
Scale: 1:5 on A1

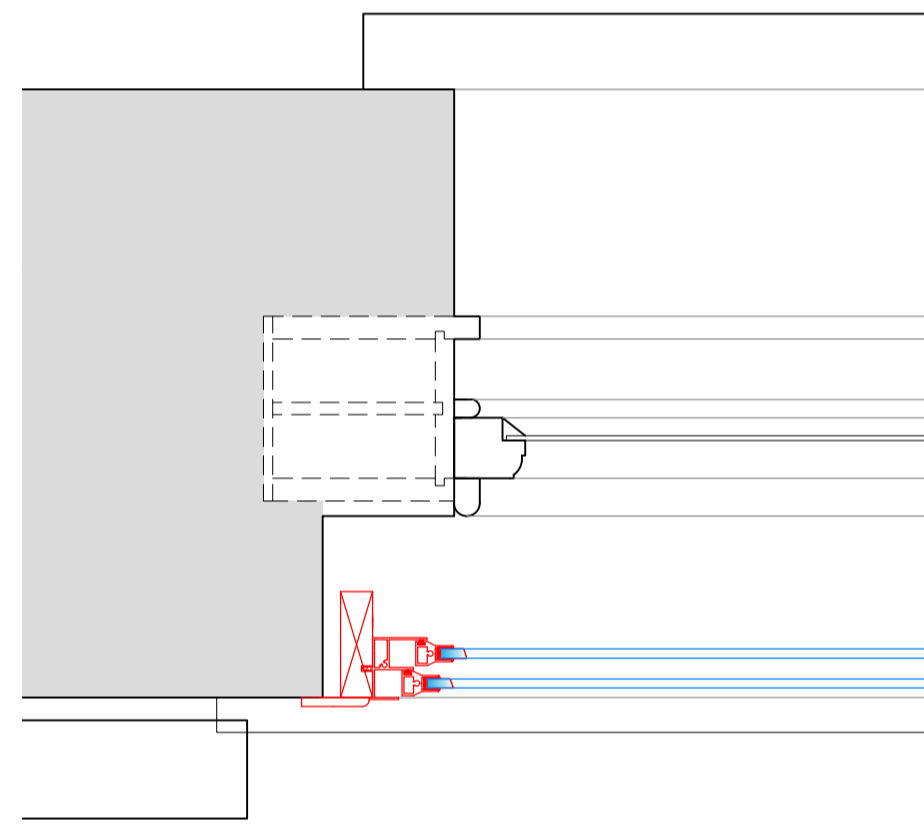

Section D-D
Scale: 1:5 on A1

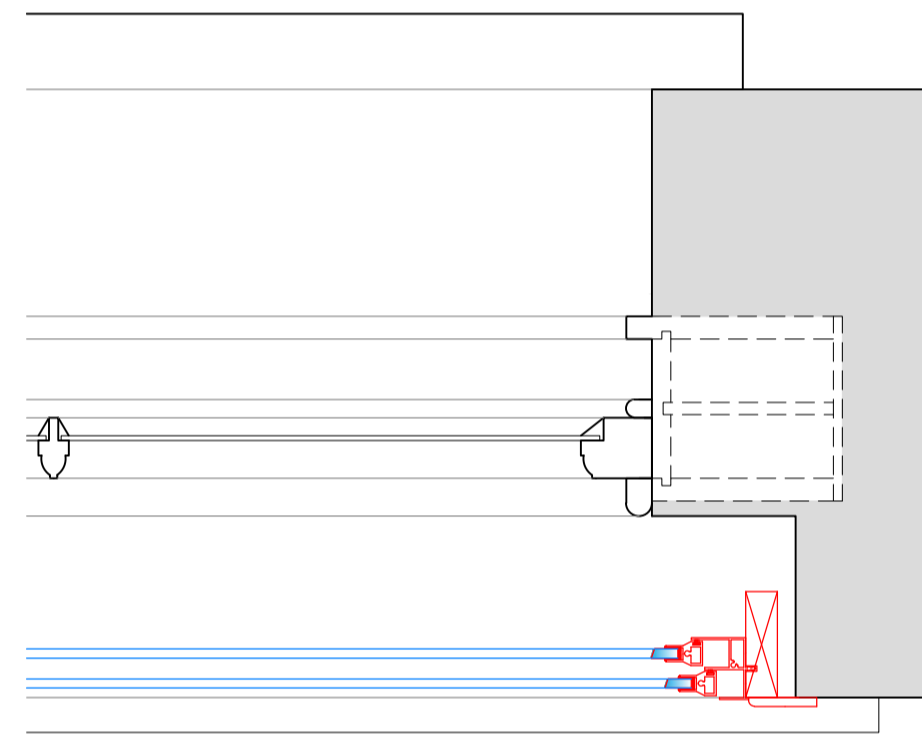

Section E-E
Scale: 1:5 on A1

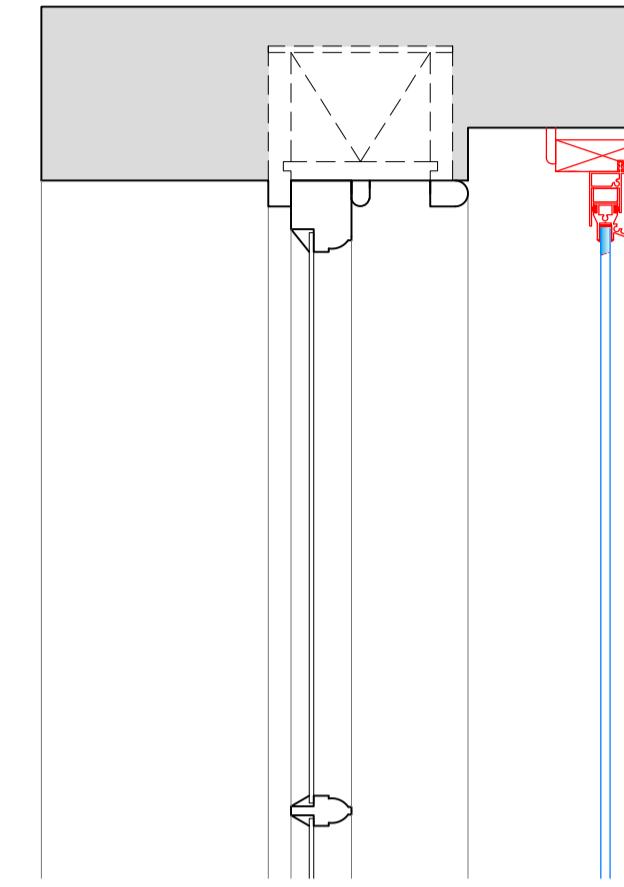

Section F-F
Scale: 1:5 on A1

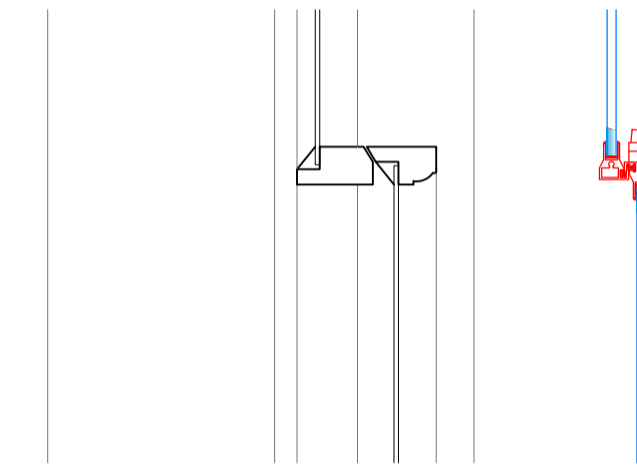

Section G-G
Scale: 1:5 on A1

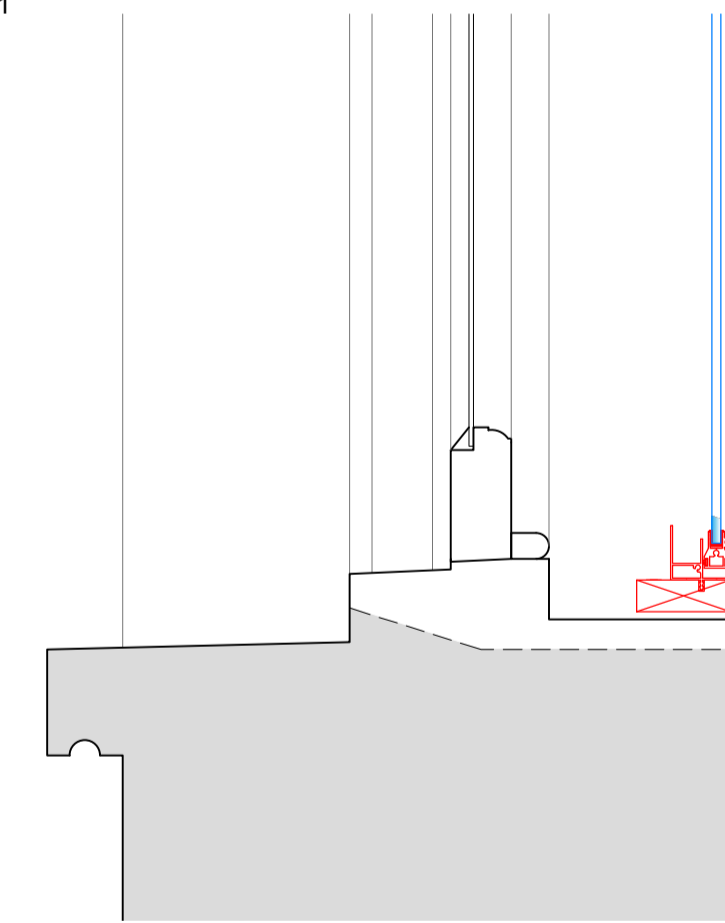

SECONDARY GLAZING SHOWN IN RED FOR VISUAL CLARITY ONLY

Revision	Date	Assessment
1.0	11-05-2021	Issued for listed building consent application

Do not reproduce this drawing without written permission
All dimensions are in millimetres unless stated otherwise

Drawing Not For Construction

HS2

High Speed (HS2) Limited
1st-3rd Floor
The Podium
1 Eversholt Street
London NW1 2DN

COSTAIN SKANSKA

Costain Skanska Joint Venture
9th Floor
The Tower
1 Eversholt Street
London NW1 2DN

Site Address: 190 North Gower Street, London NW1			
Drawing Title: Second Floor - Bedroom-402: PROPOSED Secondary Glazing Details - Sheet 3 of 3			
Drawn by: AP & OB	Drawn by: AP	Checked by: OB	Presentation Scale: 1:5 @ A1
Date: 10-05-2021	Drawing No: WPI P066 NI -190 NGS-PR-SF-J-04.2	Revision: 1.0	

Internal Room Elevation

Scale: 1:10

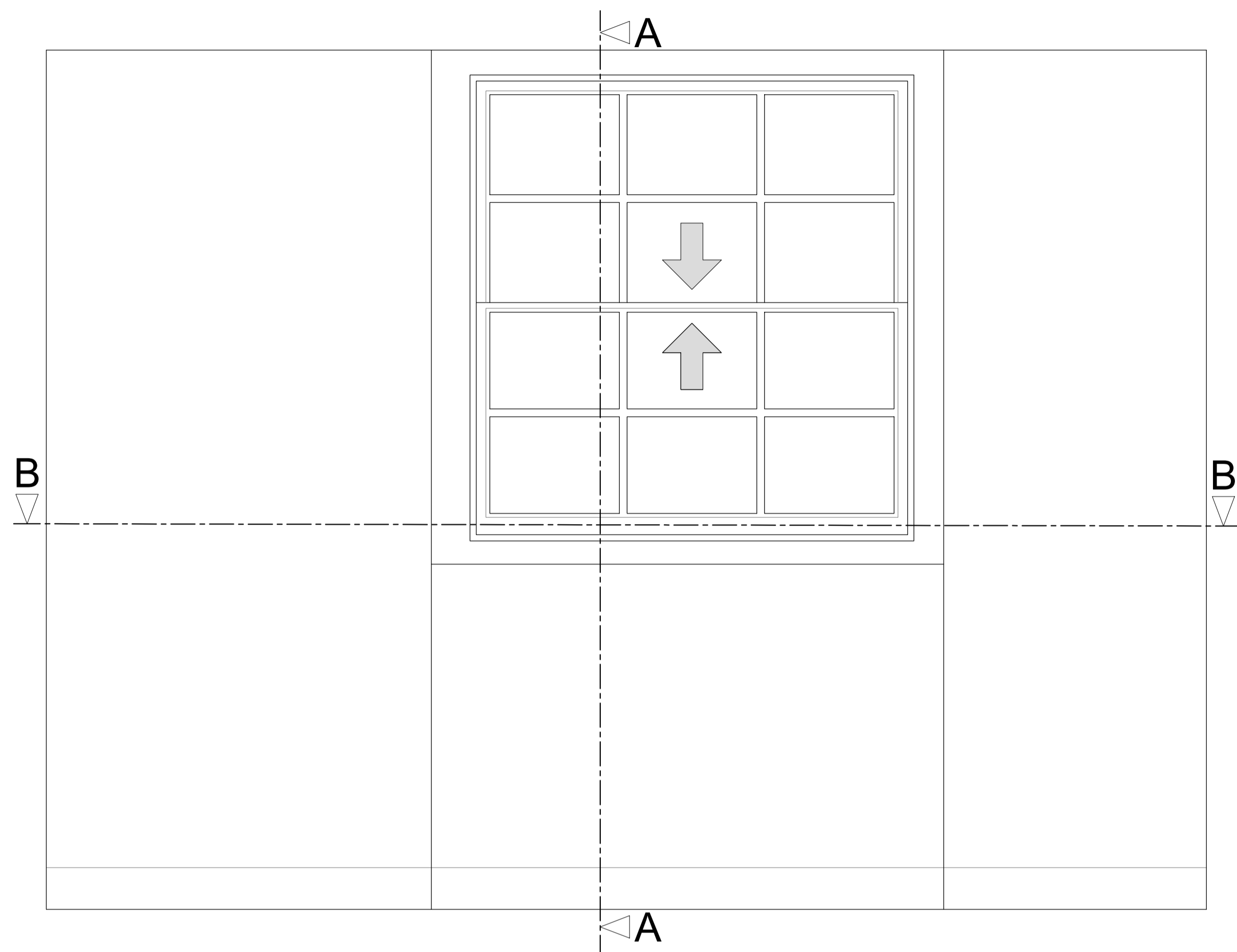

Section A-A through External Wall

Scale: 1:10

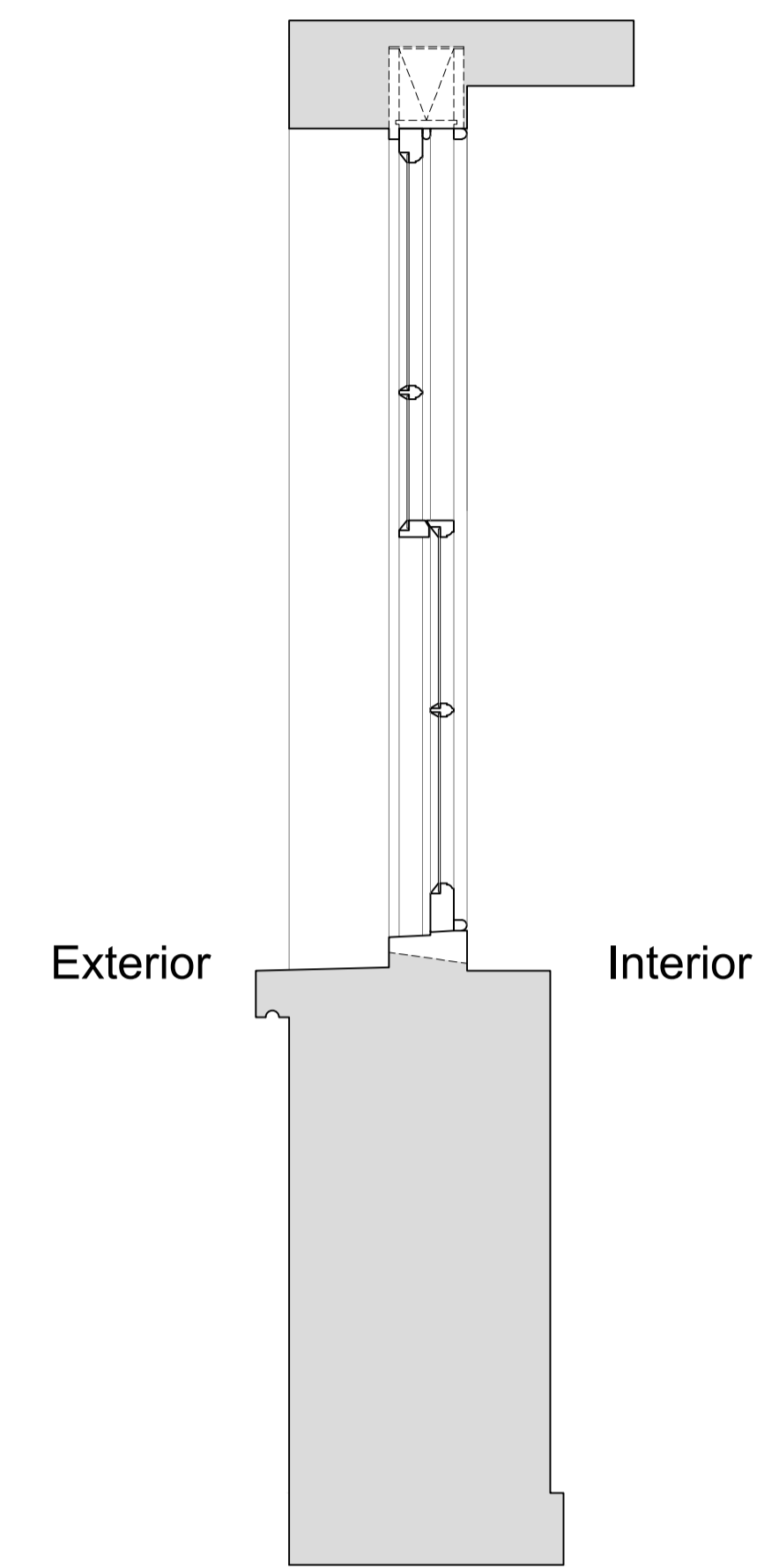

Plan Section B-B

Scale: 1:10

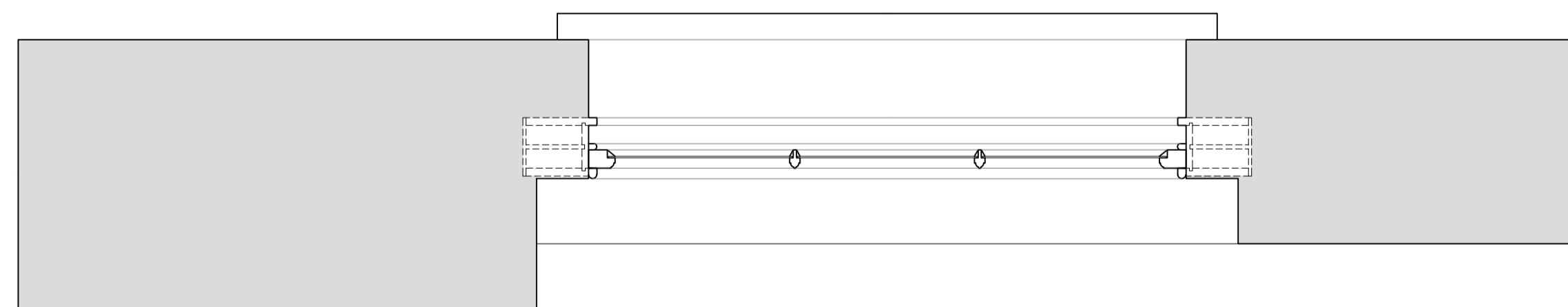

Revision	Date	Assessment
1.0	11-05-2021	Issued for listed building consent application

Do not reproduce this drawing without written permission
All dimensions are in millimetres unless stated otherwise

HS2

High Speed (HS2) Limited
1st-3rd Floor
The Tower
1 Eversholt Street
London NW1 2DN

COSTAIN SKANSKA

Costain Skanska Joint Venture
9th Floor
The Tower
1 Eversholt Street
London NW1 2DN

Site Address:
190 North Gower Street, London NW1

Drawing Title:
Third Floor - Bedroom-502:EXISTING Window Joinery Details -
Sheet 1 of 3

Drawn by: AP & OB Drawn by: AP Checked by: OB Presentation Scale: as shown @ A1

Date: 10-05-2021 Drawing No: WPI P066 NI -190 NGS-EX-TF-J-05 Revision: 1.0

Drawing Not For Construction

Internal Room Elevation with Secondary Glazing Installed

Scale: 1:10

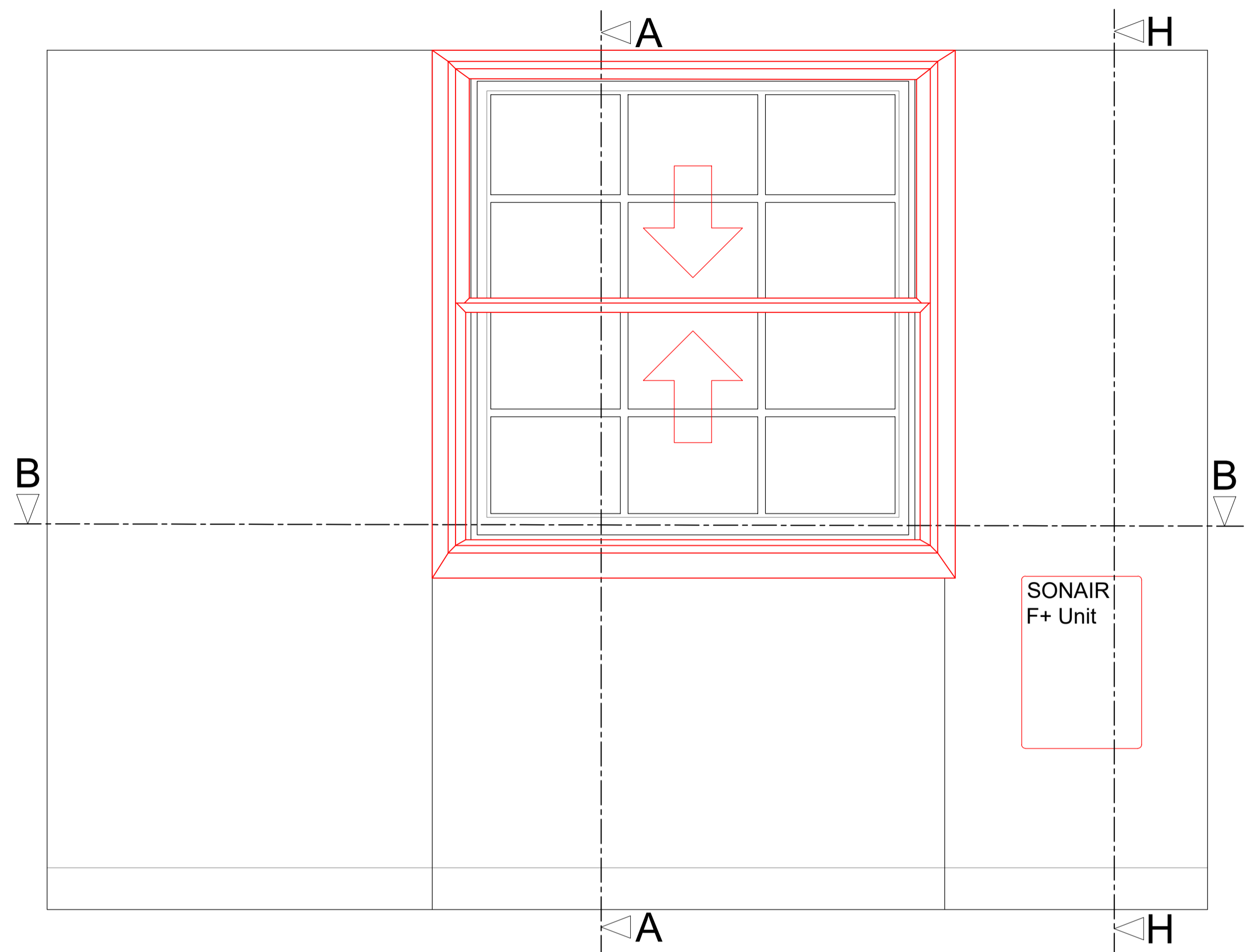

Section A-A through External Wall with Secondary Glazing Installed

Scale: 1:10

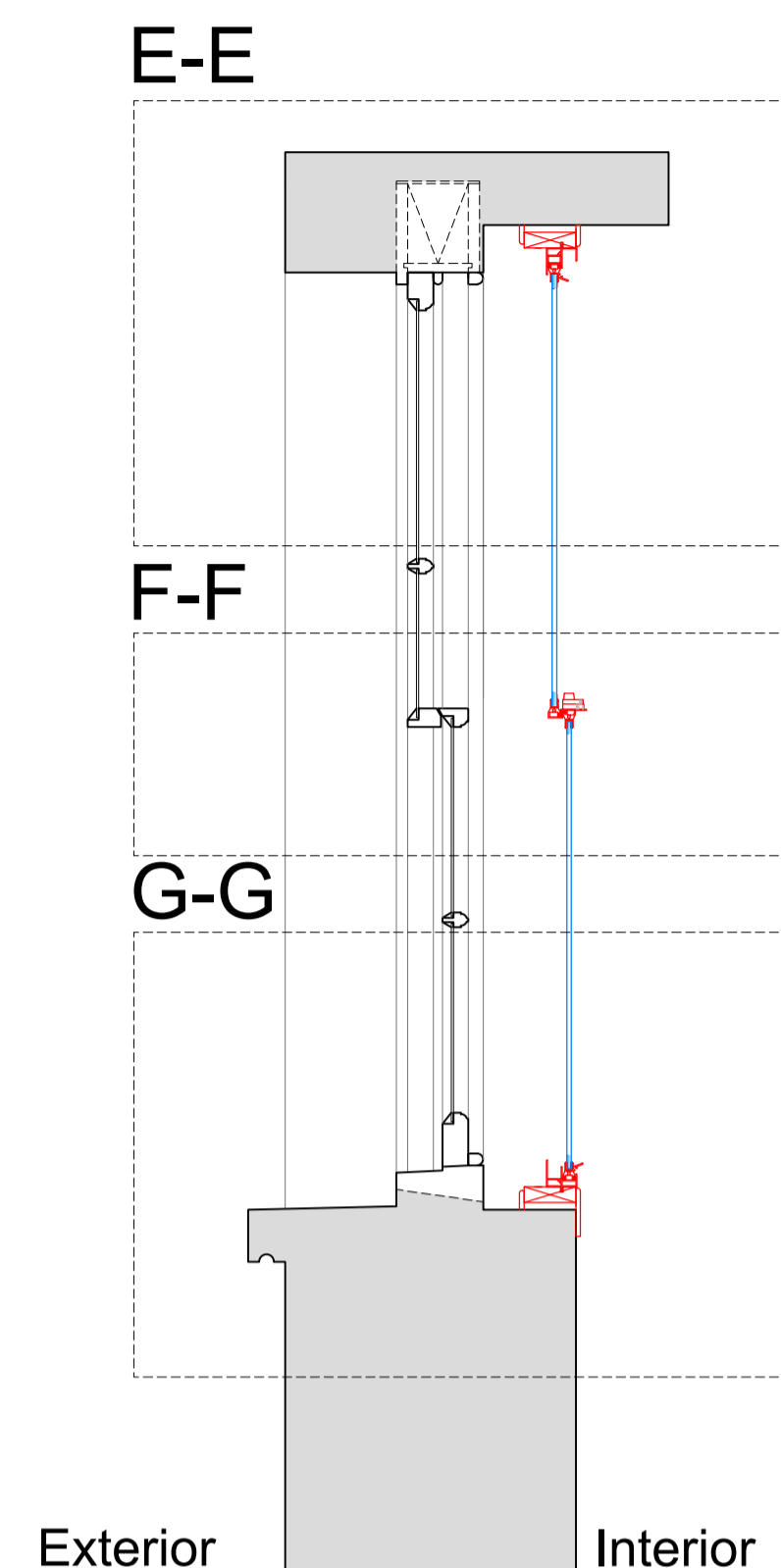

Section H-H through External Wall with Mechanical Ventilation Installed

Scale: 1:10

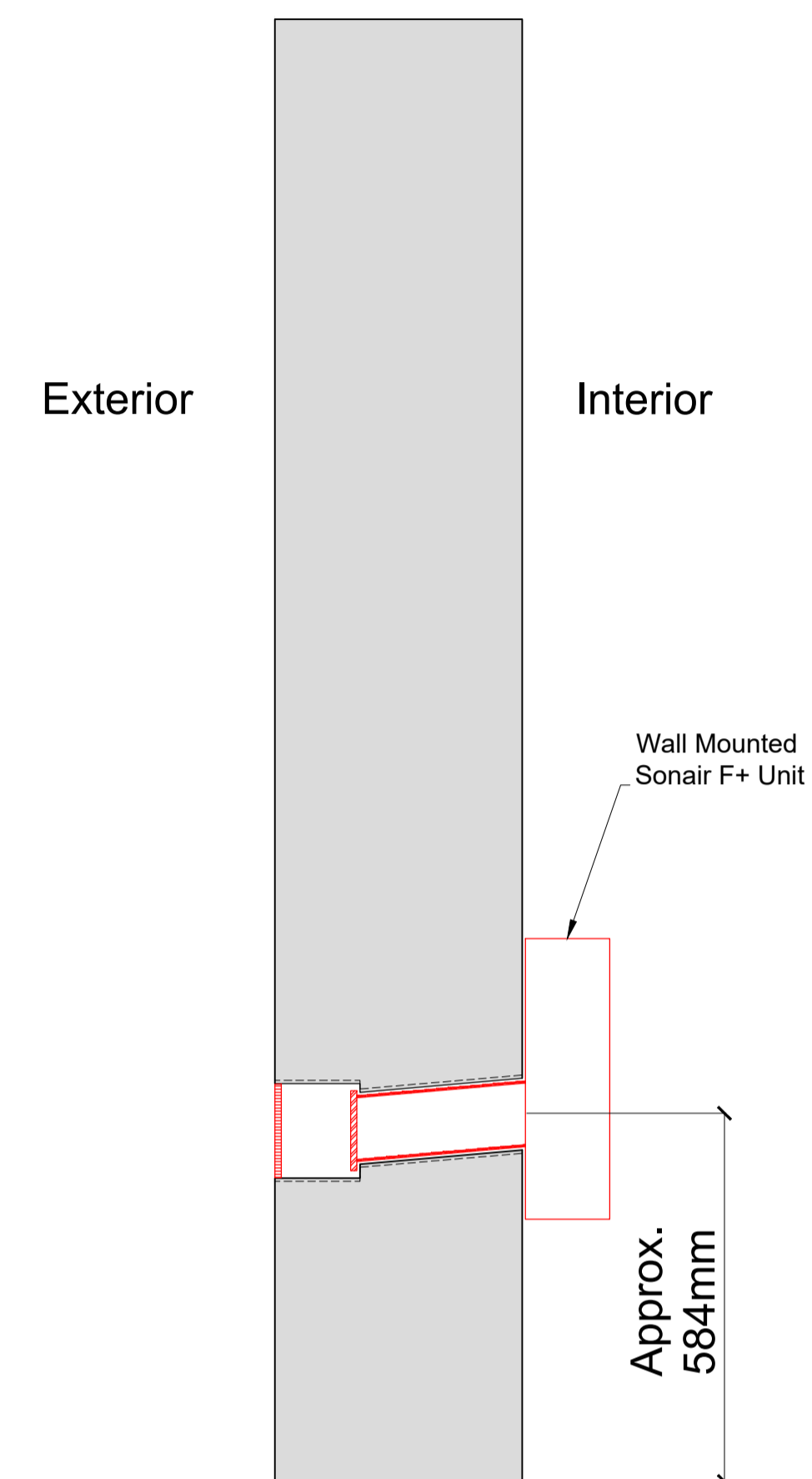

Plan Section B-B with Secondary Glazing Installed

Scale: 1:10

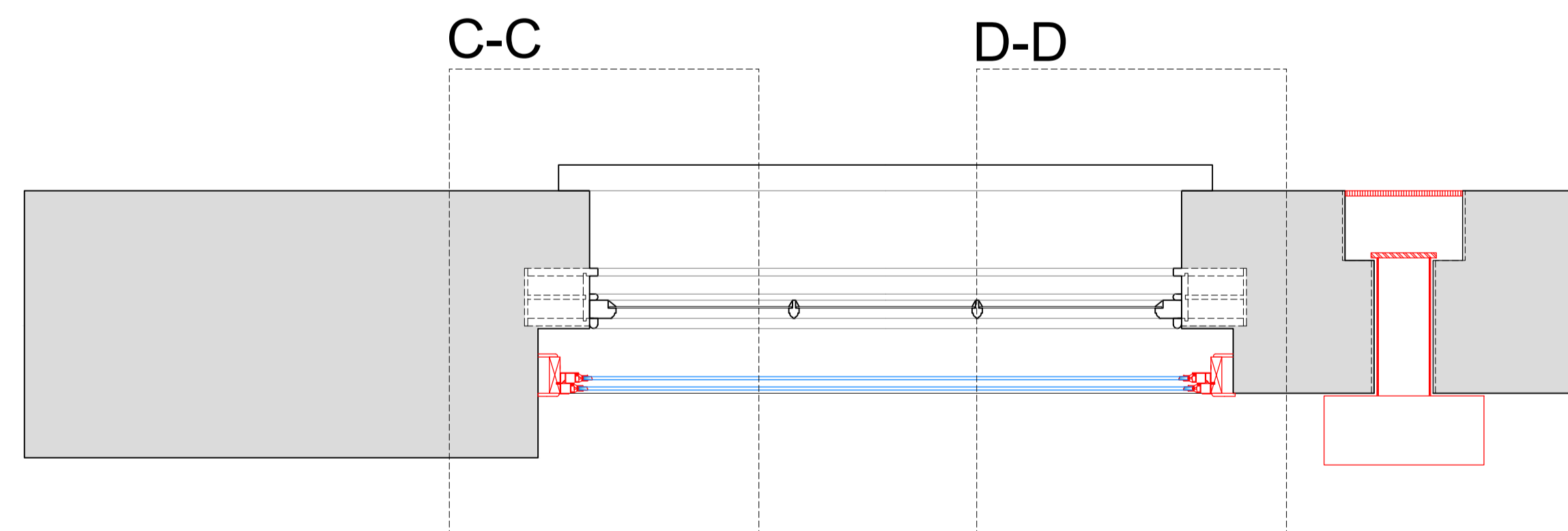

SECONDARY GLAZING SHOWN IN RED FOR VISUAL CLARITY ONLY

Revision	Date	Assessment
1.0	11-05-2021	Issued for listed building consent application

Do not reproduce this drawing without written permission
All dimensions are in millimetres unless stated otherwise

HS2

High Speed (HS2) Limited
1st-3rd Floor
The Tower
1 Eversholt Street
London NW1 2DN

COSTAIN SKANSKA

Costain Skanska Joint Venture
9th Floor
The Tower
1 Eversholt Street
London NW1 2DN

Site Address:
190 North Gower Street, London NW1

Drawing Title:
Third Floor - Bedroom-502:PROPOSED Secondary Glazing Details - Sheet 2 of 3

Drawn by: AP & OB Drawn by: AP Checked by: OB Presentation Scale: as shown @ A1

Date: 10-05-2021 Drawing No: WPI P066 NI -190 NGS-PR-TF-J-05.1 Revision: 1.0

Drawing Not For Construction

Section C-C
Scale: 1:5 on A1

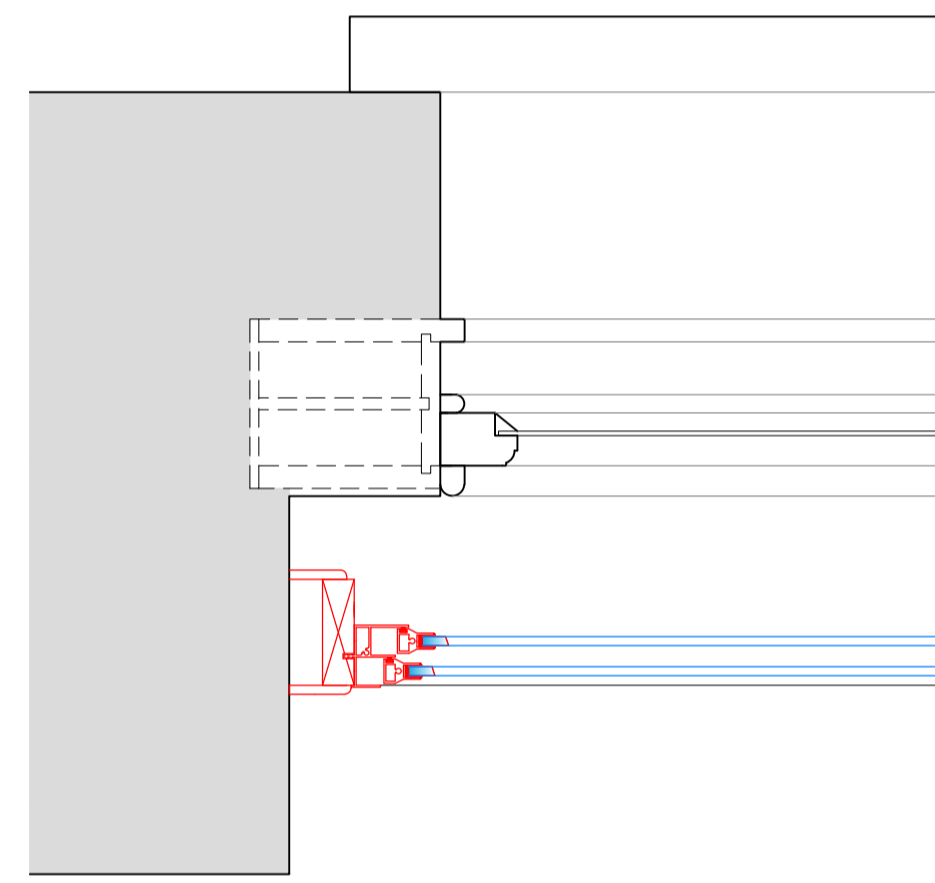

Section D-D
Scale: 1:5 on A1

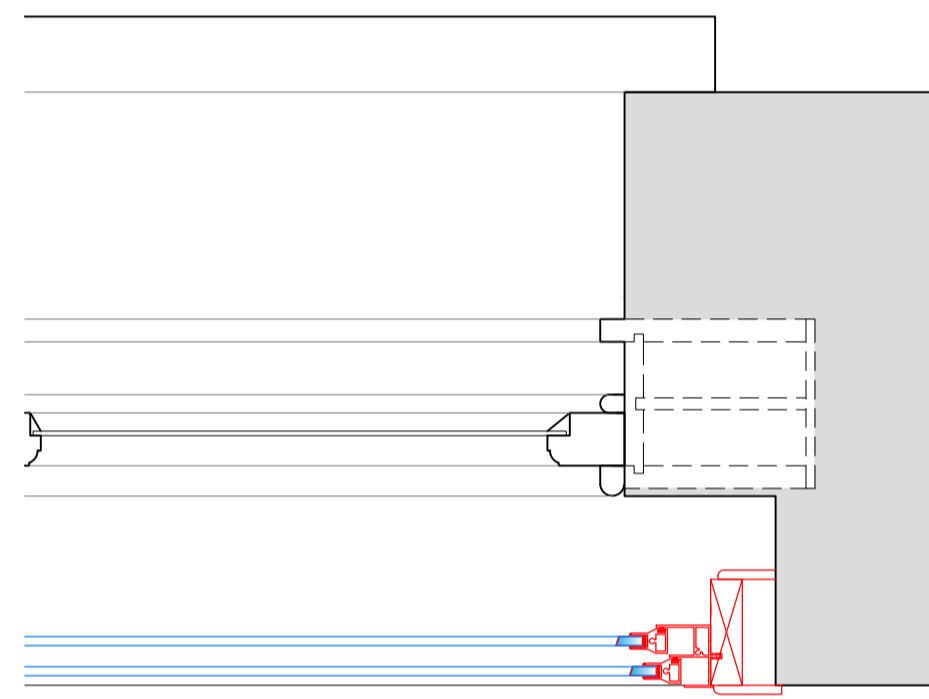

Section E-E
Scale: 1:5 on A1

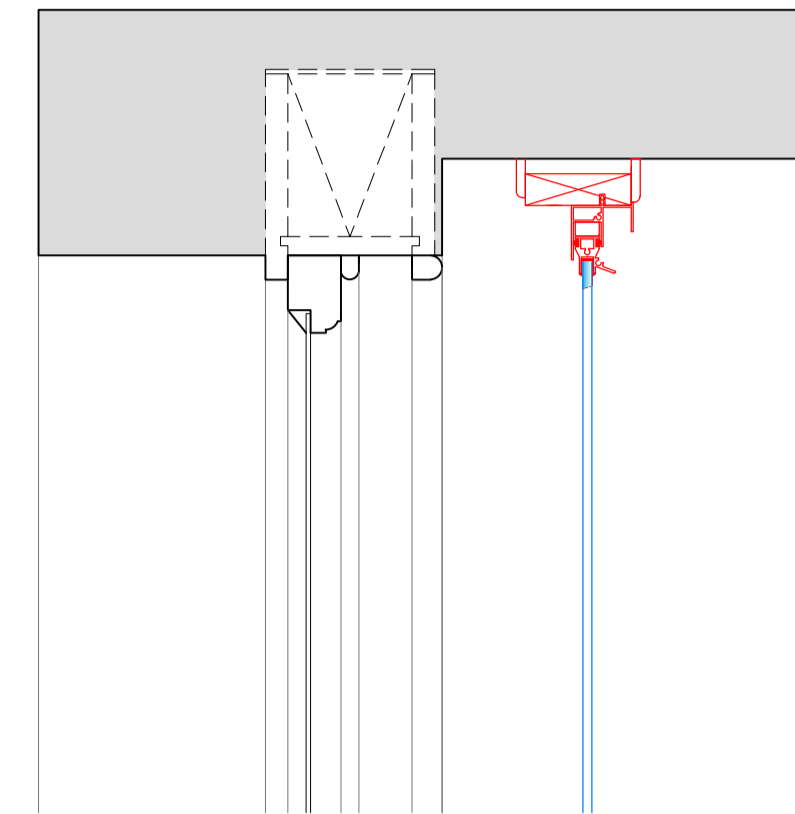

Section F-F
Scale: 1:5 on A1

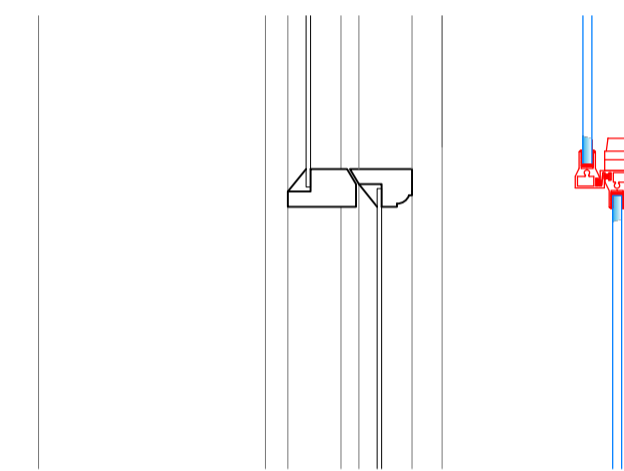

Section G-G
Scale: 1:5 on A1

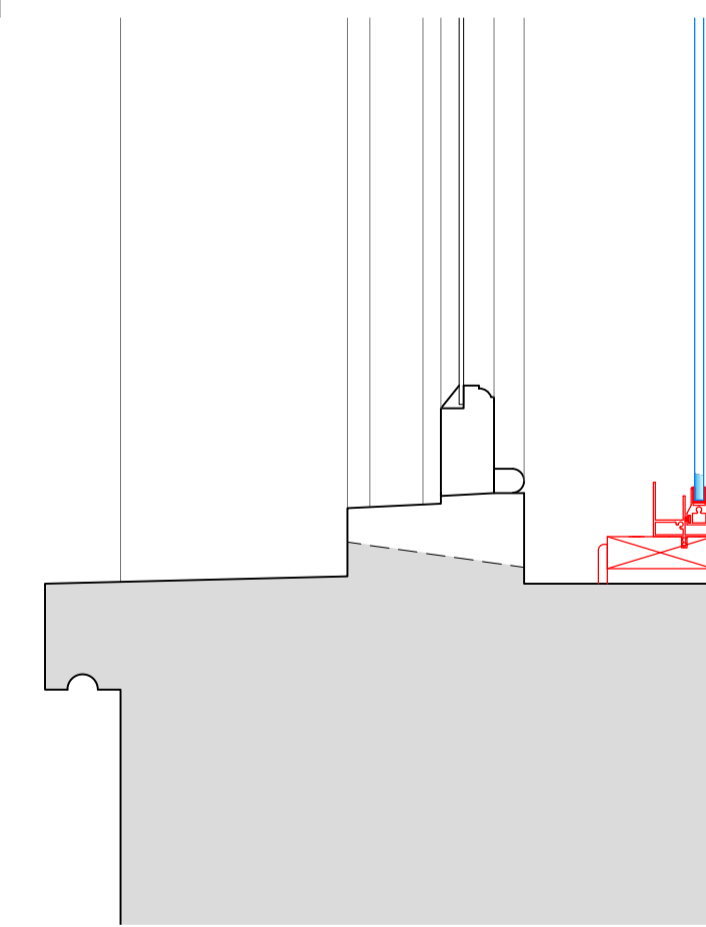

SECONDARY GLAZING SHOWN IN RED FOR VISUAL CLARITY ONLY

Revision	Date	Assessment
1.0	11-05-2021	Issued for listed building consent application

Do not reproduce this drawing without written permission
All dimensions are in millimetres unless stated otherwise

Drawing Not For Construction

HS2

High Speed (HS2) Limited
1st-3rd Floor
The Podium
1 Eversholt Street
London NW1 2DN

COSTAIN SKANSKA

Costain Skanska Joint Venture
9th Floor
The Tower
1 Eversholt Street
London NW1 2DN

Site Address: 190 North Gower Street, London NW1			
Drawing Title: Third Floor - Bedroom-502:PROPOSED Secondary Glazing Details - Sheet 3 of 3			
Drawn by: AP & OB	Drawn by: AP	Checked by: OB	Presentation Scale: 1:5 @ A1
Date: 10-05-2021	Drawing No: WPI P066 NI -190 NGS-PR-TF-J-05.2	Revision: 1.0	

Internal Room Elevation

Scale: 1:10

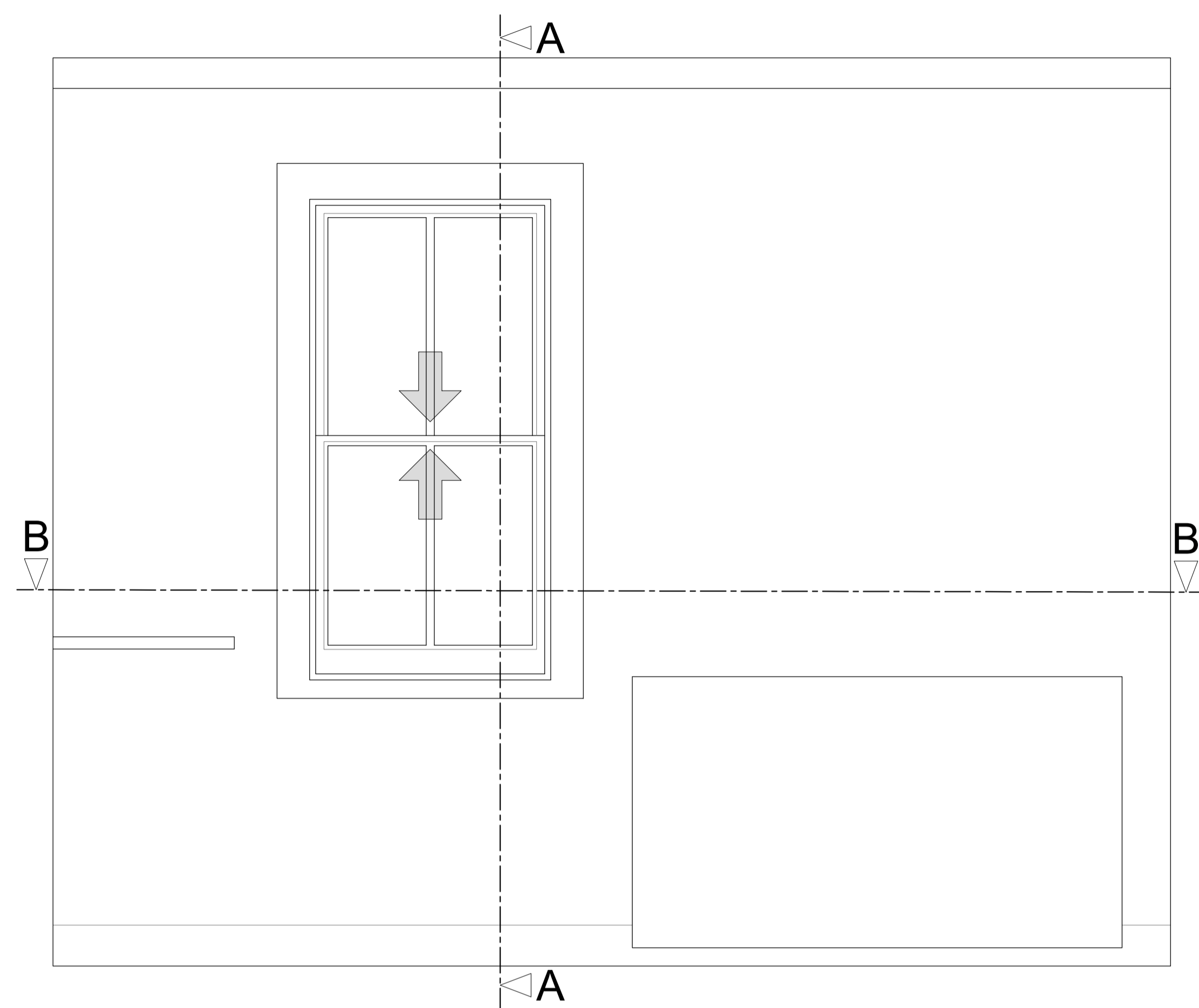

Section A-A through External Wall

Scale: 1:10

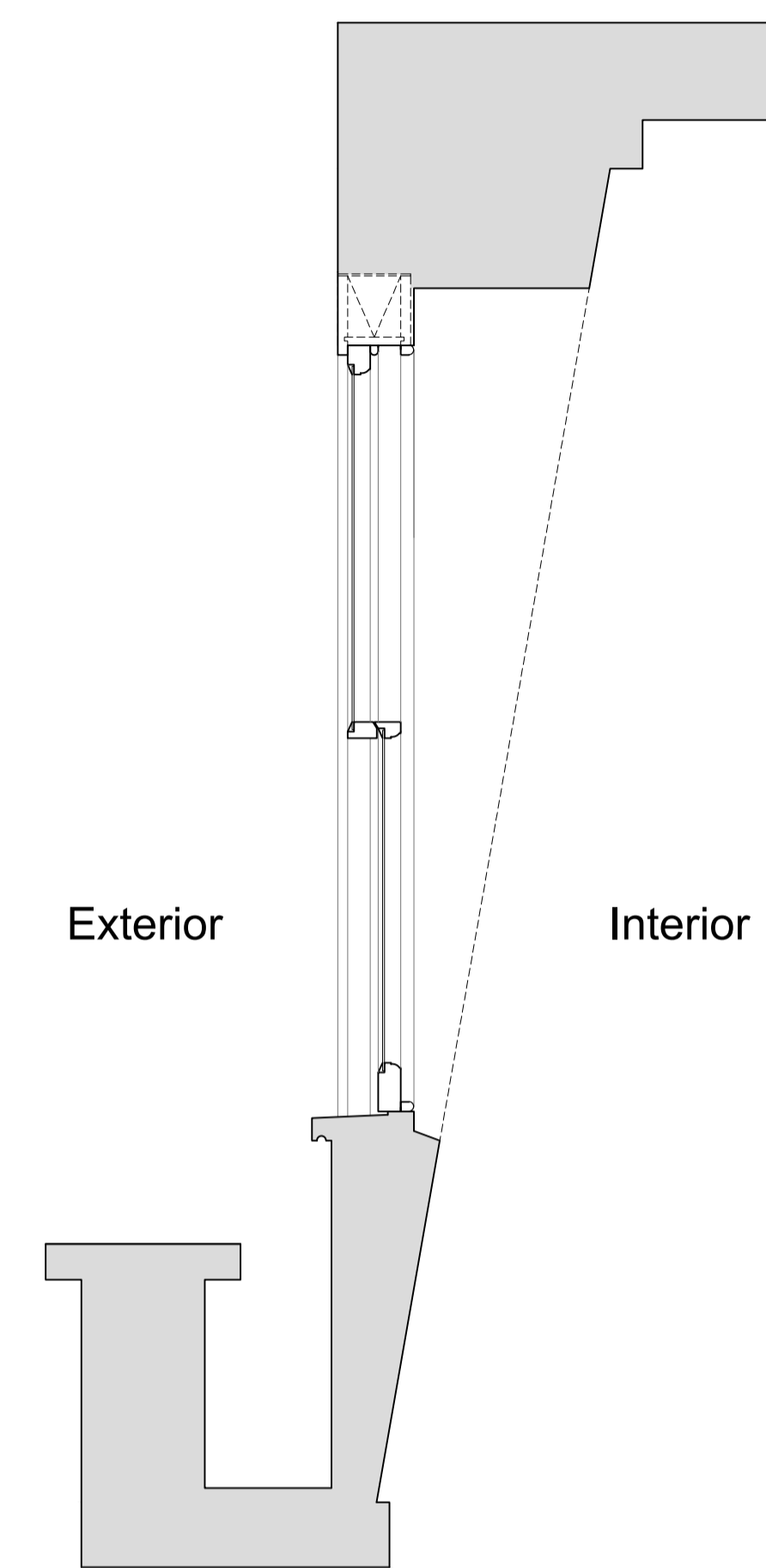

Plan Section B-B

Scale: 1:10

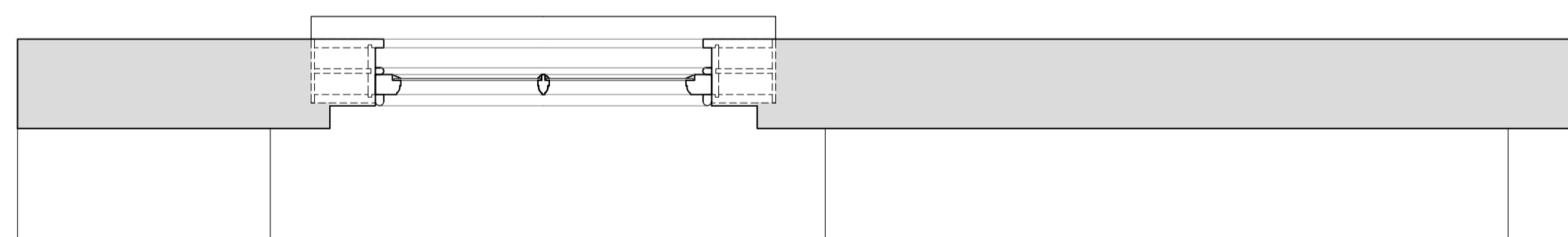

Revision	Date	Assessment
1.0	11-05-2021	Issued for listed building consent application

Do not reproduce this drawing without written permission
All dimensions are in millimetres unless stated otherwise

Drawing Not For Construction

HS2

High Speed (HS2) Limited
1st-3rd Floor
The Podium
1 Eversholt Street
London NW1 2DN

COSTAIN SKANSKA

Costain Skanska Joint Venture
9th Floor
The Tower
1 Eversholt Street
London NW1 2DN

Site Address: 190 North Gower Street, London NW1			
Drawing Title: Third Floor - Bedroom-502-REAR:EXISTING Window Joinery Details - Sheet 1 of 3			
Drawn by: AP & OB	Checked by: AP	Reviewed by: OB	Presentation Scale: as shown @ A1
Date: 10-05-2021	Drawing No: WPI P066 NI -190 NGS-EX-TF-J-06	Revision: 1.0	

Internal Room Elevation with Secondary Glazing Installed

Scale: 1:10

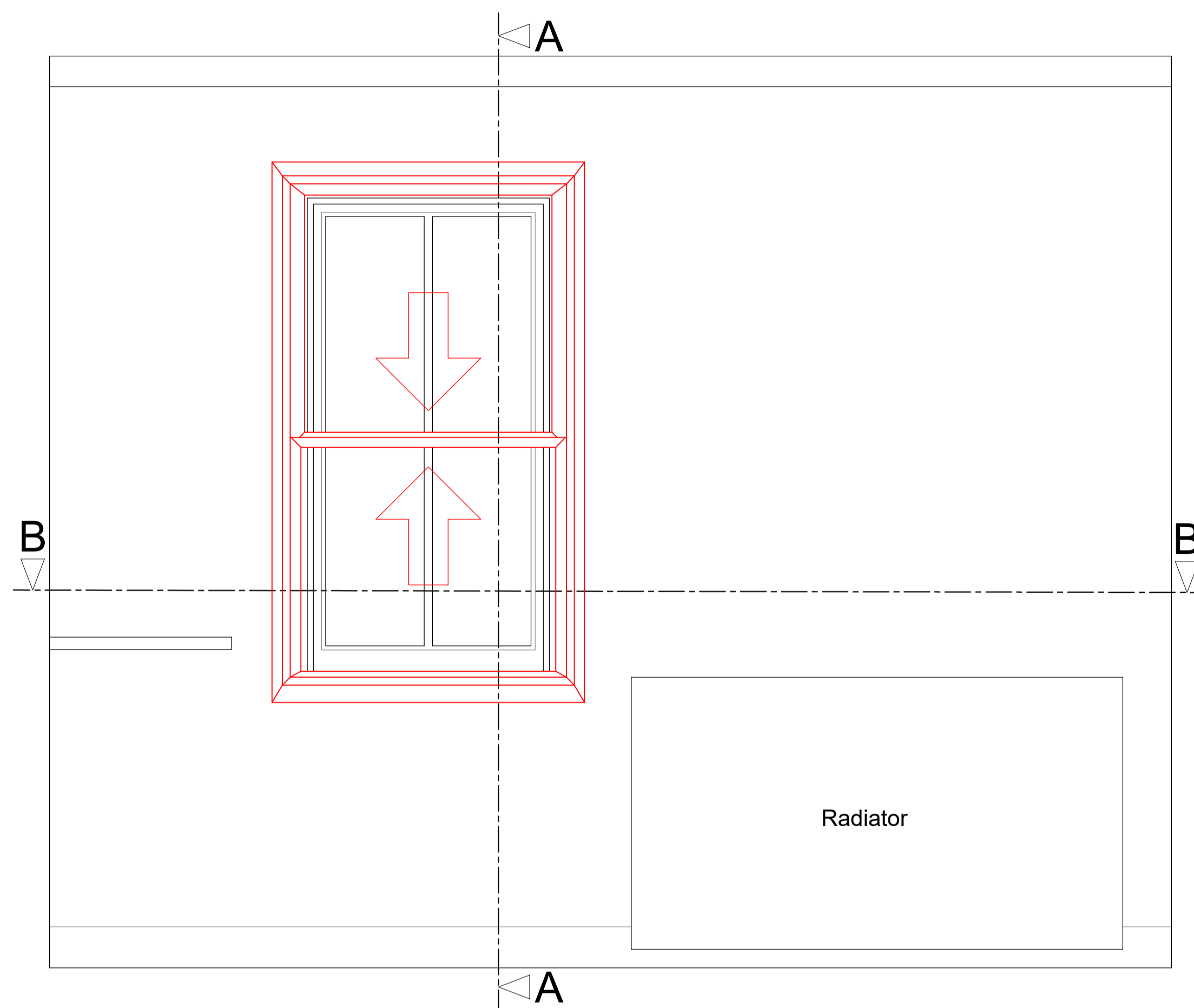

Section A-A through External Wall with Secondary Glazing Installed

Scale: 1:10

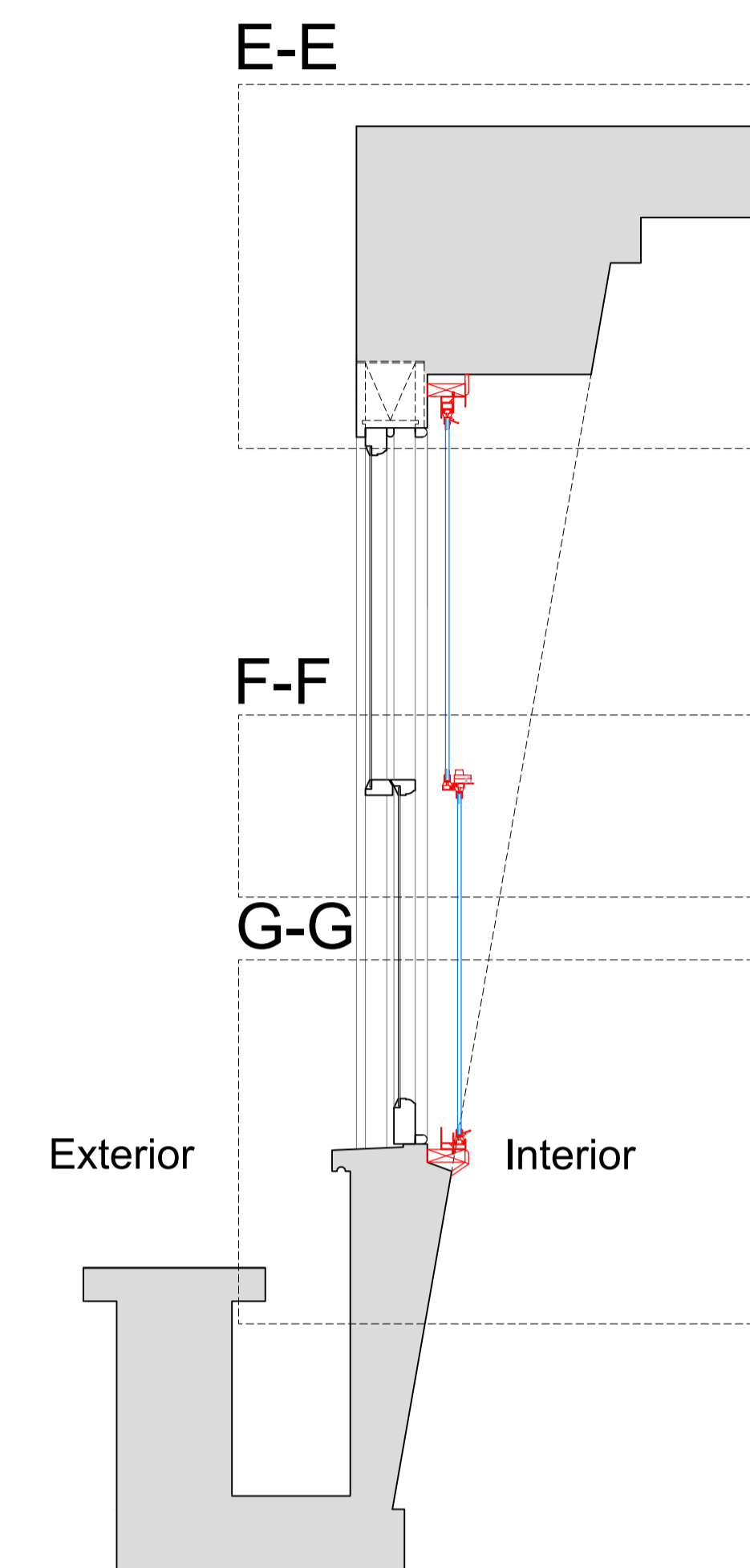

Plan Section B-B with Secondary Glazing Installed

Scale: 1:10

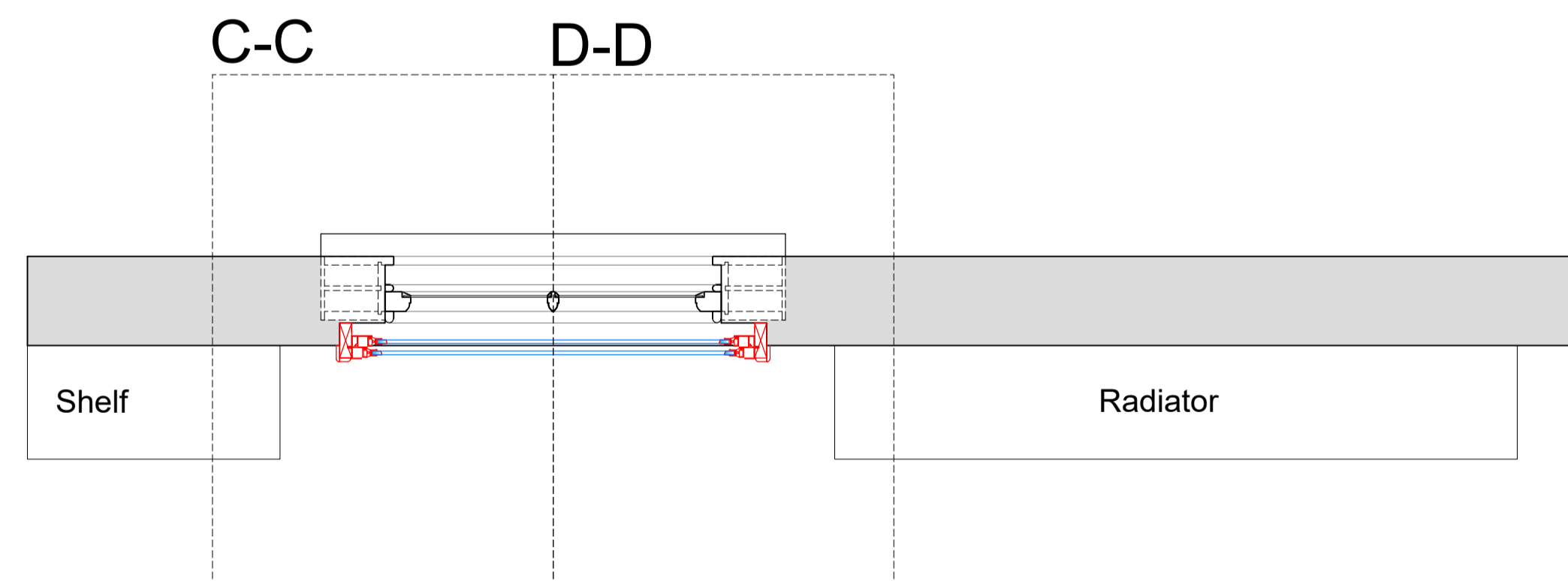

SECONDARY GLAZING SHOWN IN RED FOR VISUAL CLARITY ONLY

Revision	Date	Assessment
1.0	11-05-2021	Issued for listed building consent application

Do not reproduce this drawing without written permission
All dimensions are in millimetres unless stated otherwise

HS2

High Speed (HS2) Limited
1st-3rd Floor
The Podium
1 Eversholt Street
London NW1 2DN

COSTAIN SKANSKA

Costain Skanska Joint Venture
9th Floor
The Tower
1 Eversholt Street
London NW1 2DN

Site Address:
190 North Gower Street, London NW1

Drawing Title:
Third Floor - Bedroom-502-REAR:PROPOSED Secondary Glazing Details - Sheet 2 of 3

Drawn by: AP & OB
Checked by: AP
Presentation Scale: as shown @ A1

Date: 10-05-2021
Drawing No: WPI P066 NI -190 NGS-PR-TF-J-06.1
Revision: 1.0

Drawing Not For Construction

Section C-C
Scale: 1:5 on A1

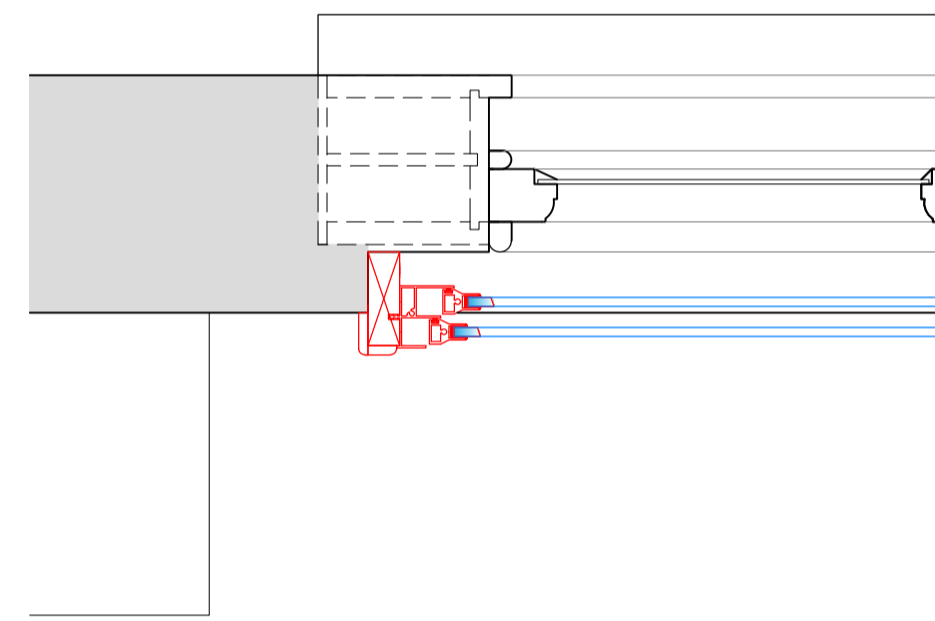

Section D-D
Scale: 1:5 on A1

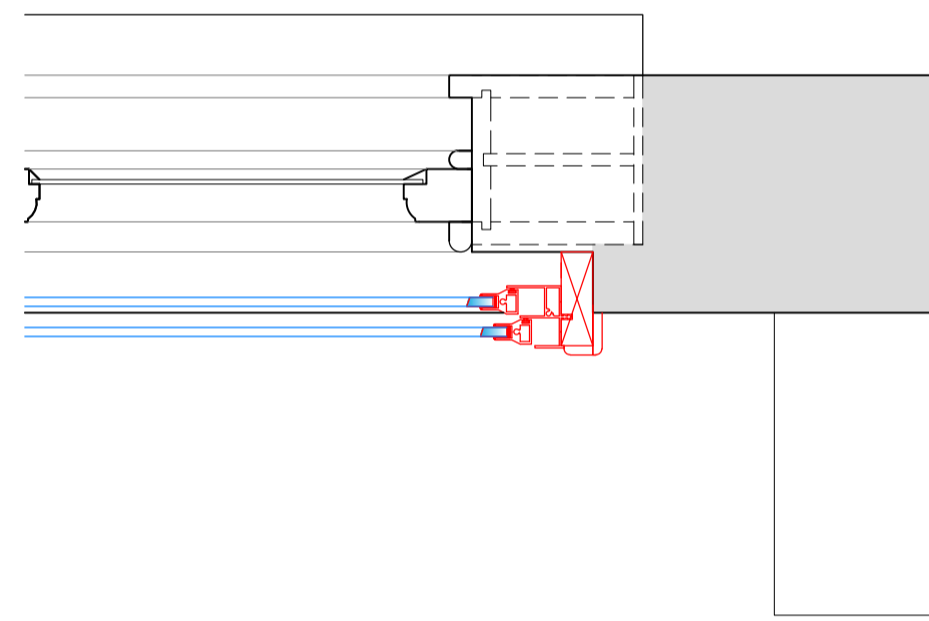

Section E-E
Scale: 1:5 on A1

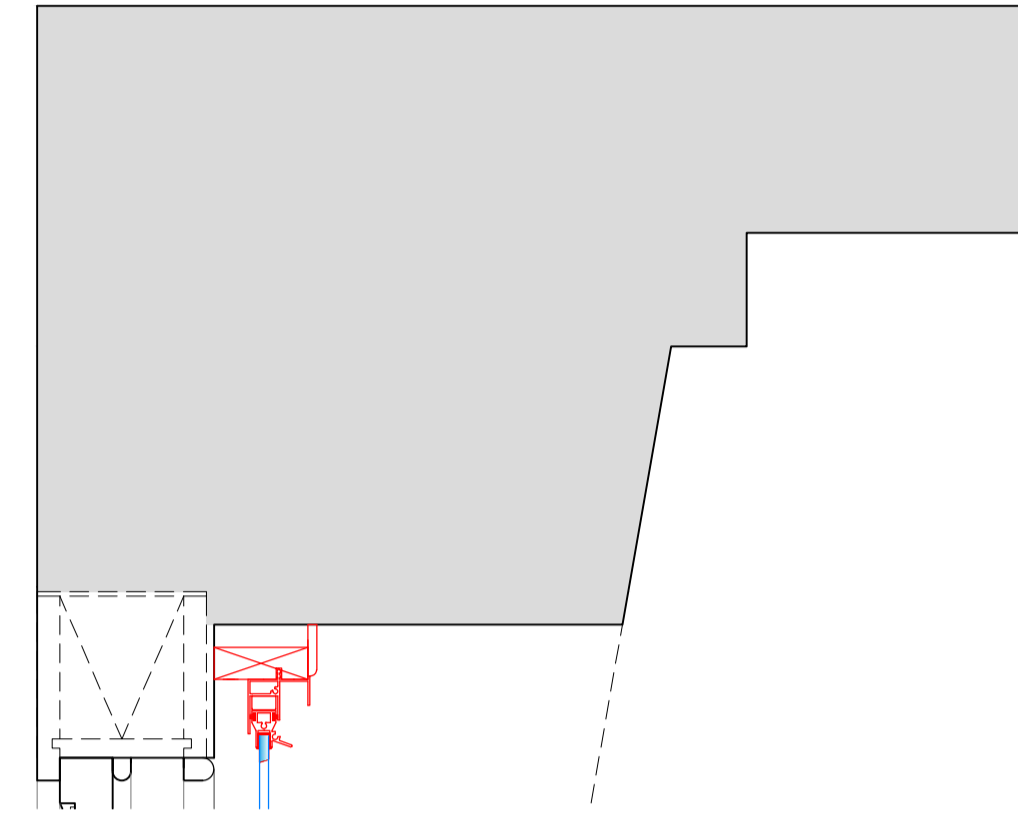

Section F-F
Scale: 1:5 on A1

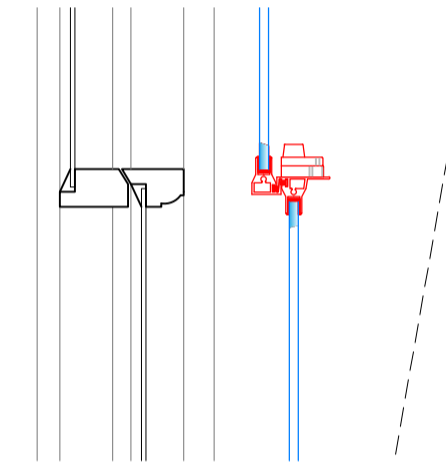

Section G-G
Scale: 1:5 on A1

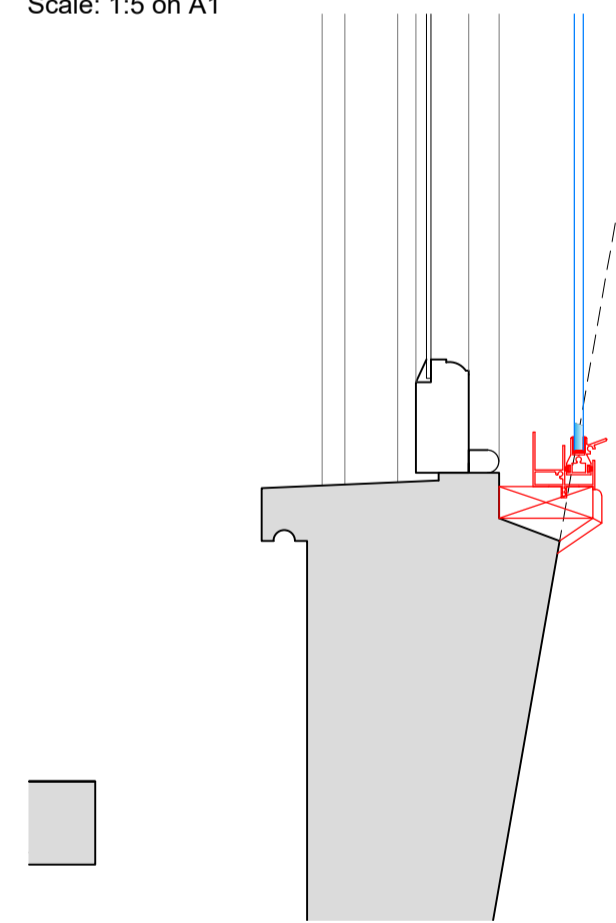

SECONDARY GLAZING SHOWN IN RED FOR VISUAL CLARITY ONLY

Revision	Date	Assessment
1.0	11-05-2021	Issued for listed building consent application

Do not reproduce this drawing without written permission
All dimensions are in millimetres unless stated otherwise

Drawing Not For Construction

HS2

High Speed (HS2) Limited
1st-3rd Floor
The Podium
1 Eversholt Street
London NW1 2DN

COSTAIN SKANSKA

Costain Skanska Joint Venture
9th Floor
The Tower
1 Eversholt Street
London NW1 2DN

Site Address: 190 North Gower Street, London NW1			
Drawing Title: Third Floor - Bedroom-502-REAR:PROPOSED Secondary Glazing Details - Sheet 3 of 3			
Drawn by: AP & OB	Drawn by: AP	Checked by: OB	Presentation Scale: 1:5 @ A1
Date: 10-05-2021	Drawing No: WPI P066 NI -190 NGS-PR-TF-J-06.2	Revision: 1.0	