

P1 Concrete Block Paving - Bond Detail
Q24/115B
1:10

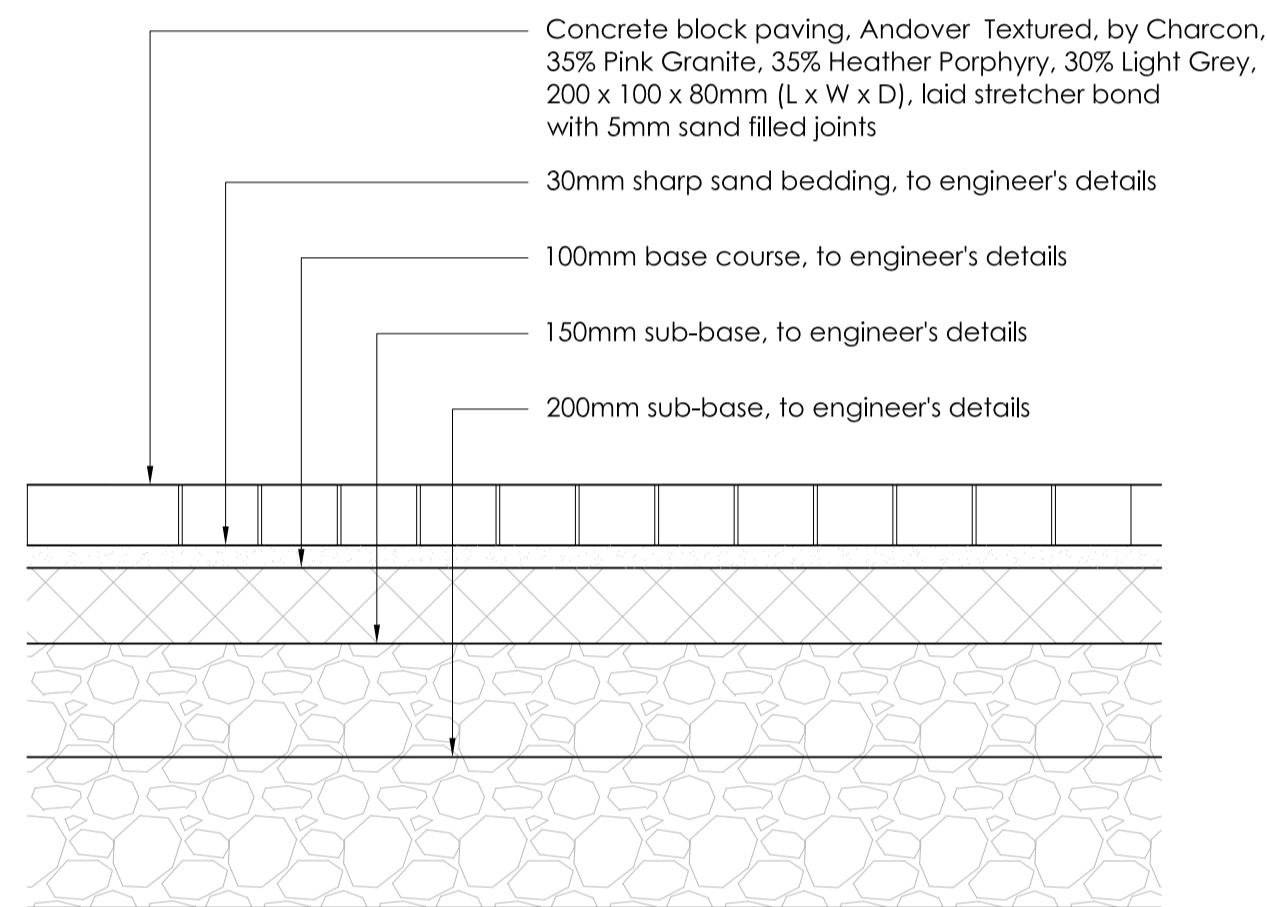

P1 Concrete Block Paving Build-up Detail
Q24/115B
1:10

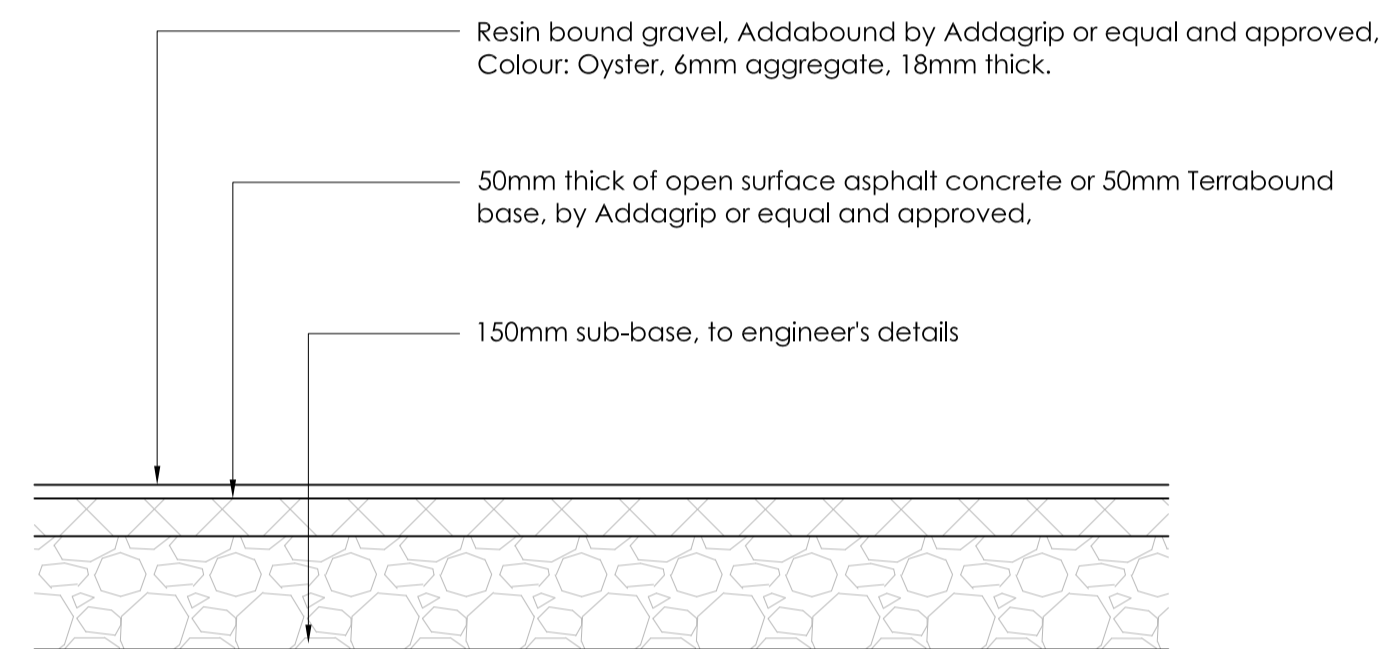

P2 Resin Bound Gravel Build-up Detail
Q23/225C
1:10

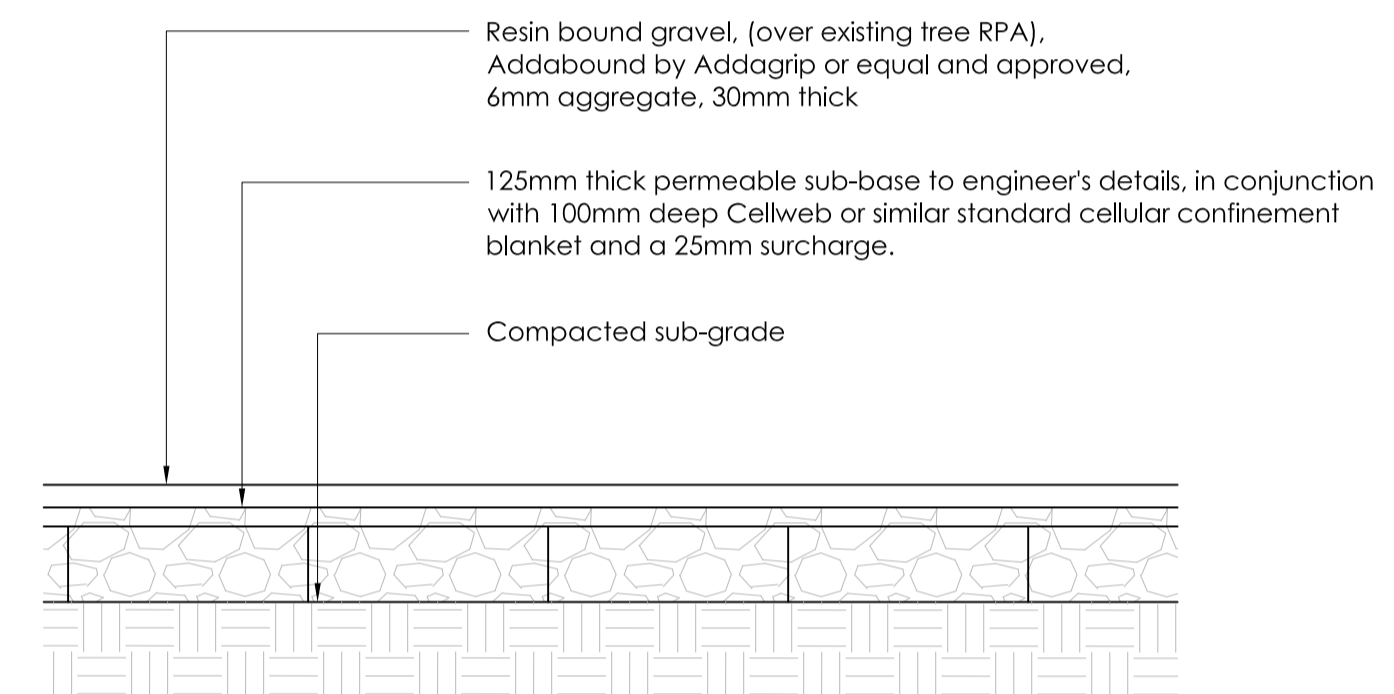

P2a Resin Bound Gravel over Existing Tree RPA Build-up Detail
Q23/225C
1:10

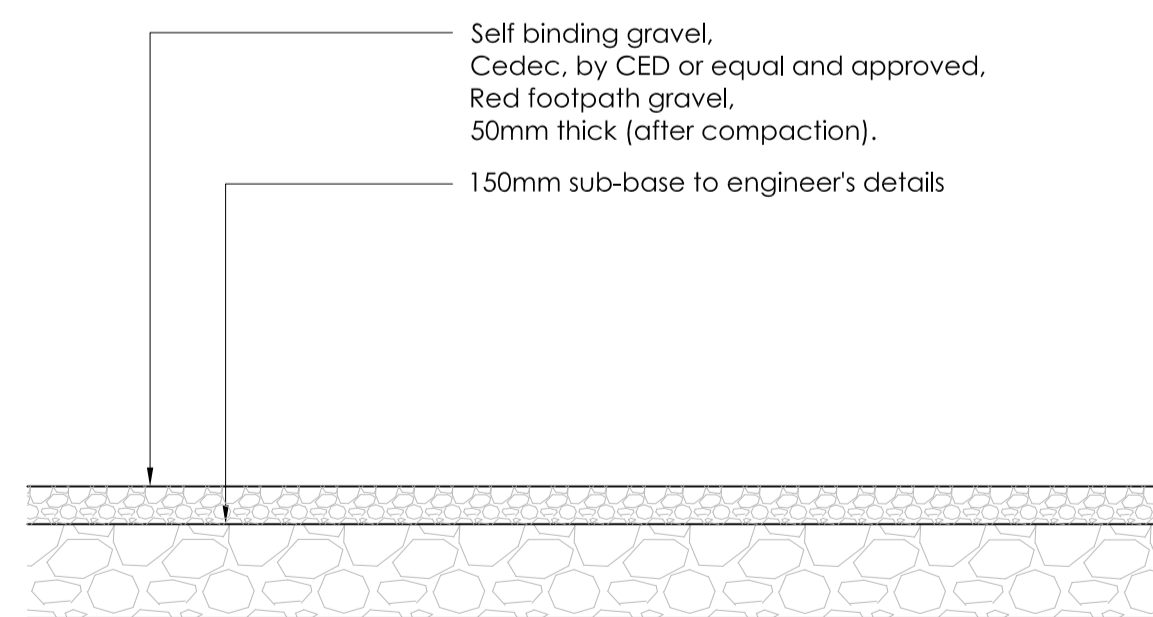

P3 Self Binding Gravel Build-up Detail
Q23/110A
1:10

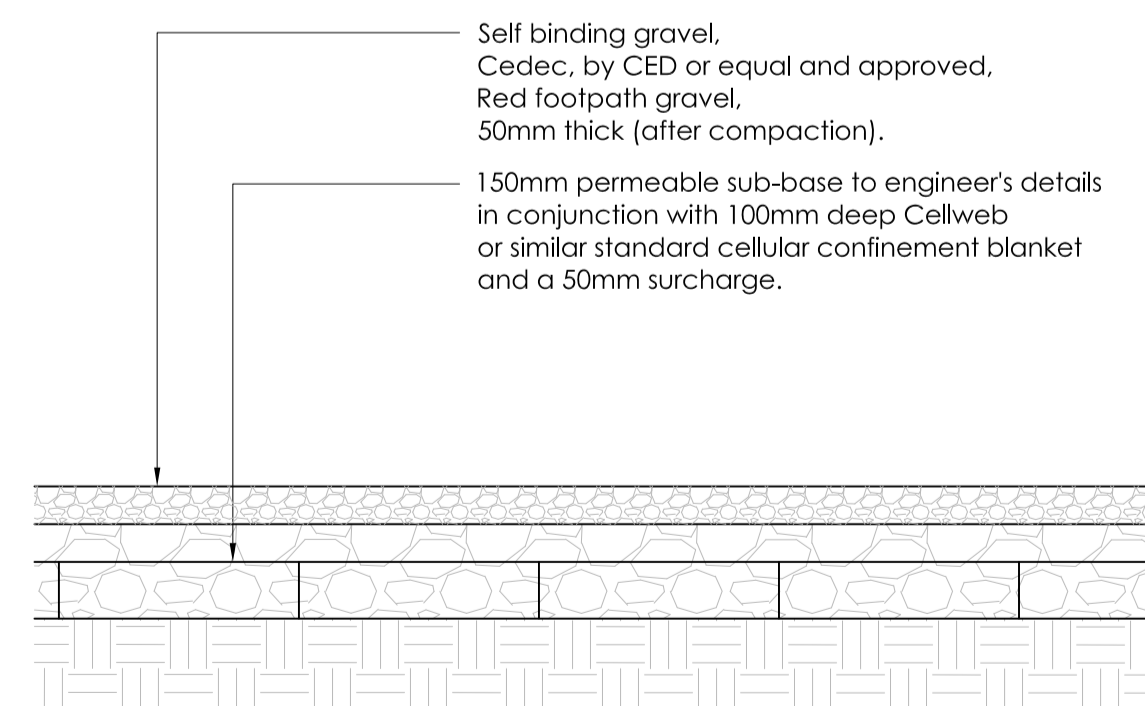

P3a Self Binding Gravel Beneath Existing Trees Build-up Detail
Q23/110A
1:10

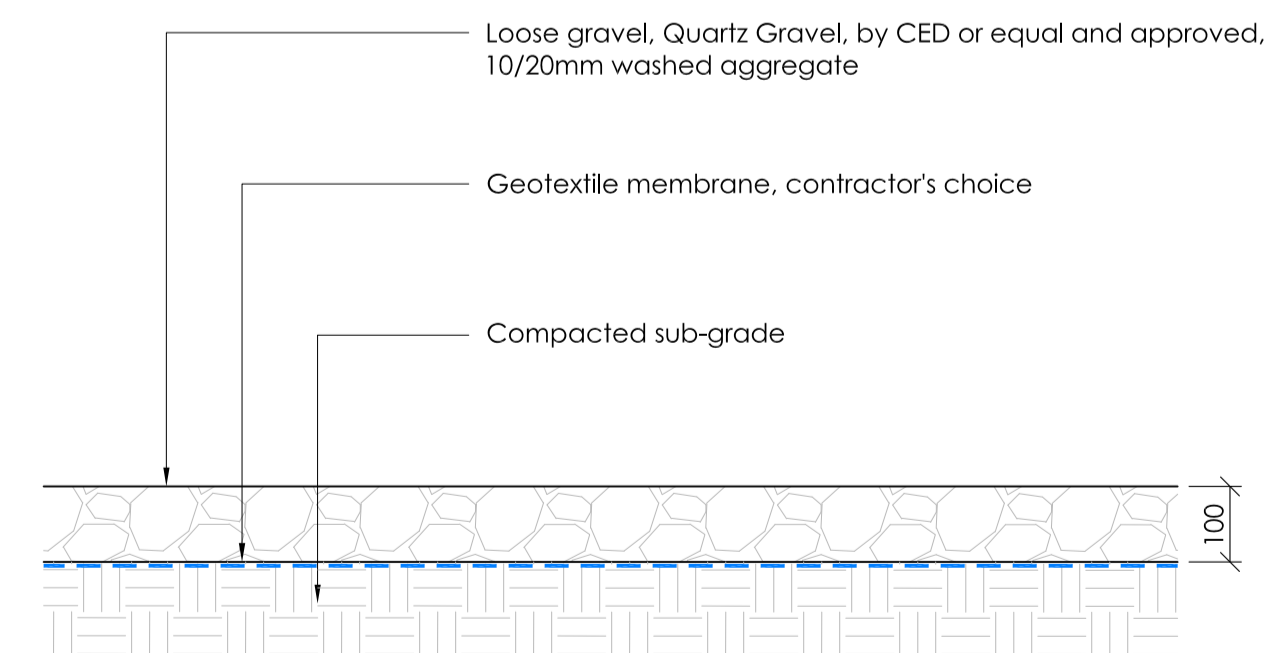

P4 Loose gravel Build-up Detail
Q23/160B
1:10

NO.	REV.	DATE	DESCRIPTION	BY	CHK	APP
S3	P02	22/05/2020	Stage 4 Issue			AC TS
S1	P01	22/04/2020	First Issue			AC TS

STATUS	REV	DATE	DESCRIPTION	DSG	DRW	CHK	APP
ALL REVISIONS							

MAIN CONTRACTOR



Bouygues UK
Becket House
1 Lambeth Palace Rd
Lambeth, London SE1 7EU
Tel: 020 7401 0020

CLIENT LOGO

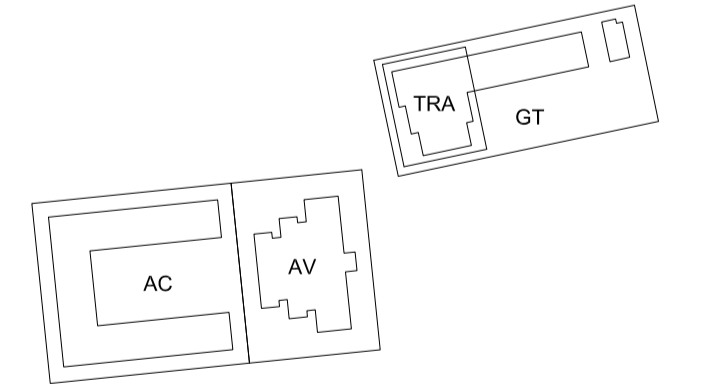
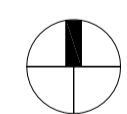

KEY PLAN

ORIGINATOR



Studio 3 04 Chester House, Kennington Park
1-3 Brixton Road, London, SW9 6DE
T: (+44) 020 3567 1050
E: studio@turkingtonmartin.com

PROJECT NAME
Maitland Park Redevelopment

DRAWING TITLE
Typical Paving Details 1 of 2

SCALE @ A1	MODEL FILE NAME - REVISION	
1:10	Not Applicable	
FIRST ISSUE DATE	PROJECT STAGE	STATUS CODE
22/04/2020	Stage 4	S3 - Suitable for Review & Comments

PROJECT	ORIGINATOR	VOLUME	LEVEL	TYPE	ROLE	NUMBER	REV
MPR	TMA	ZZ	GF	DT	L	300001	P02