

NOTES

- Carefully remove and discard existing door and associated fittings, casings, beads, linings and architraves up to line of the solid panel housing the ventilation grille above door. Ventilation plenum box over and associated panel to be retained.
- Set existing room name and way finding signage to one side for future reapplication.
- Make good remaining door opening.
- Supply and fit new casing / lining as per specification to suit door leaf dimensions shown. Increase lining as necessary to align with the retained framework over the door opening. Casing depth to suit wall / partition thickness.
- Apply fire resistant / intumescent flexible sealant around casing and wall abutment.
- Apply new architraves and make good existing skirtings.
- Supply and fit new door and associated fixtures and fittings as per relevant door specification (refer to door schedule)
- Check, ease and adjust door operation.
- Fit retained room name and way finding signage to door.

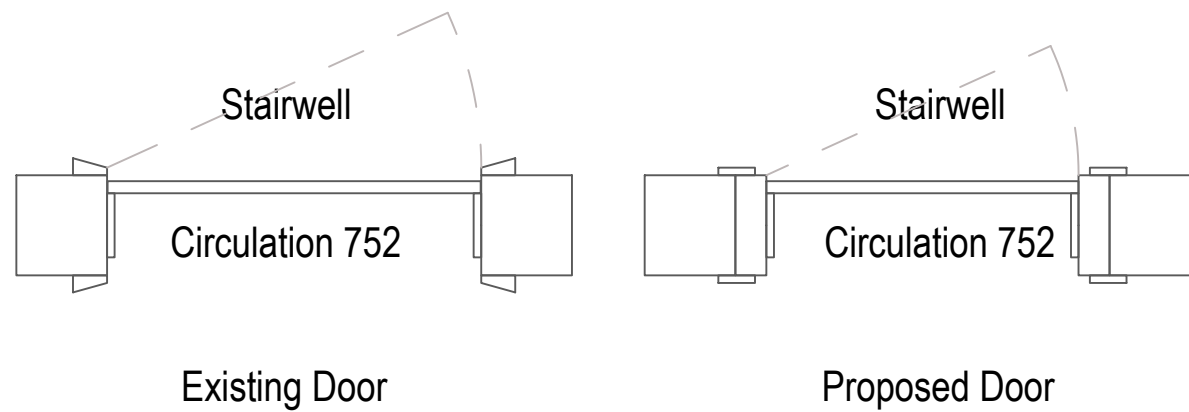

Rev	Date	Description	Initials
Client			
CAMDEN WMC			
Project Name			
CAMDEN WMC DOOR SCHEDULE			
Drawing Title			
LEVEL 7 DOOR 121			
Issue Status			
LISTED BUILDING CONSENT			
Scale & Paper Size	Date Originated	Drawn	
1:20@A3	18-03-21	VP	
Project No.	Stage	No.	Rev.
P404	-	027	0

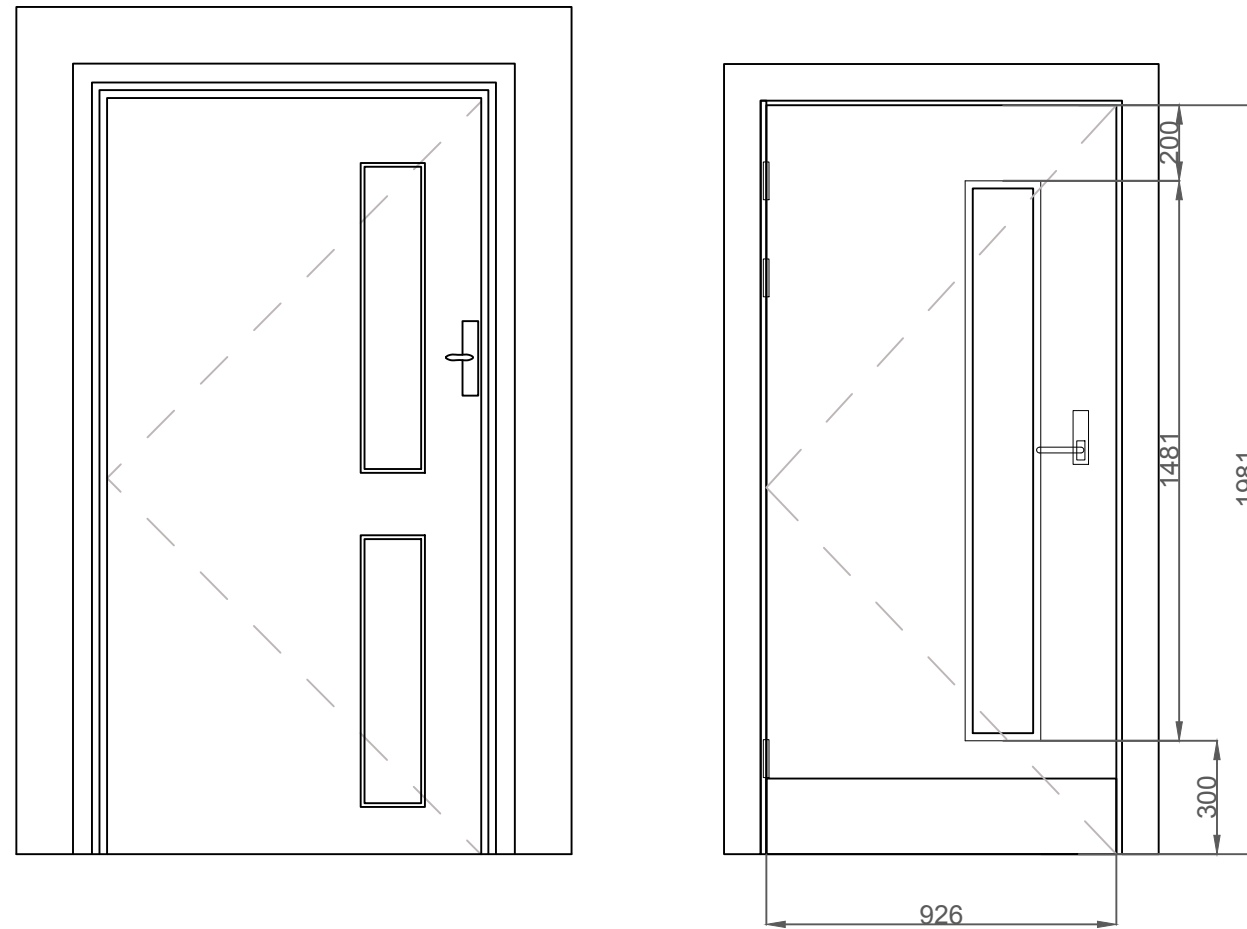