

Elevation A

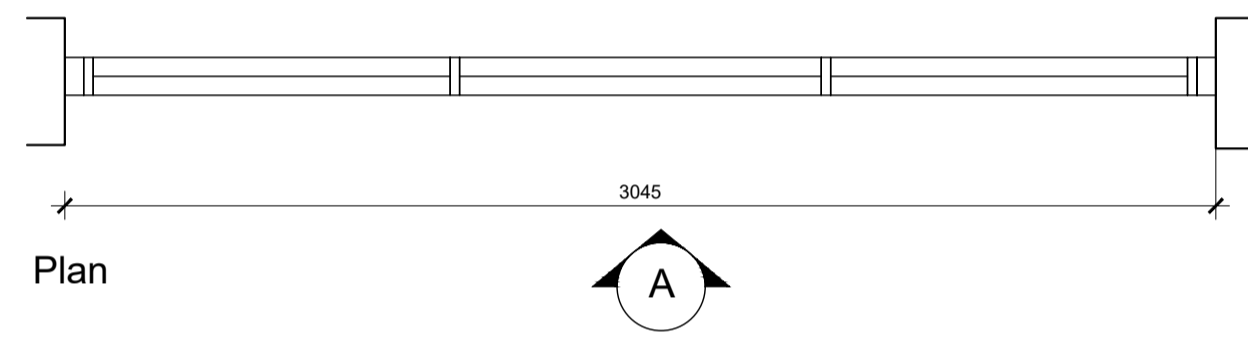

WINDOW TYPE: W1  
WINDOW NUMBERS: W0B.01B

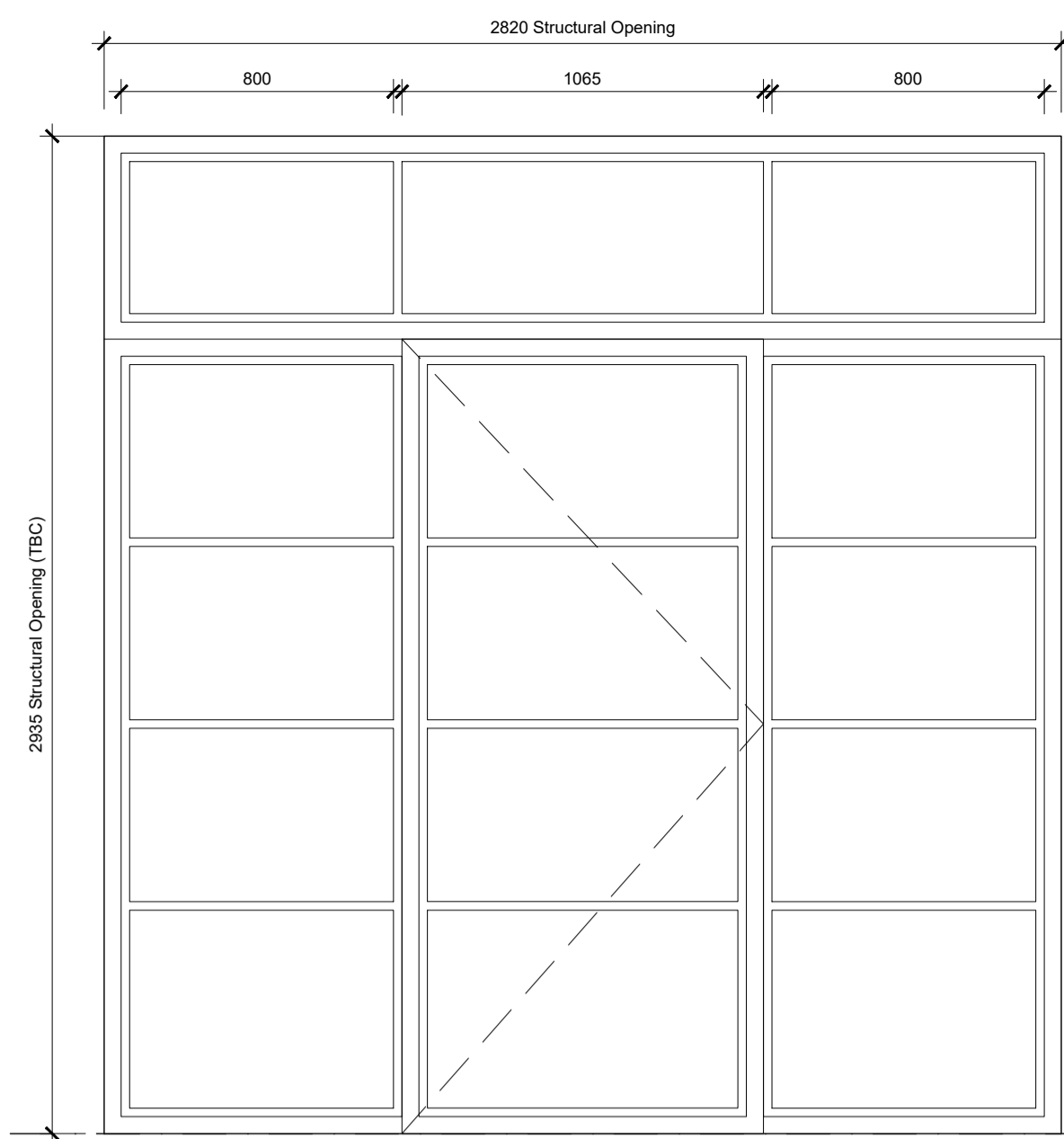

Elevation A

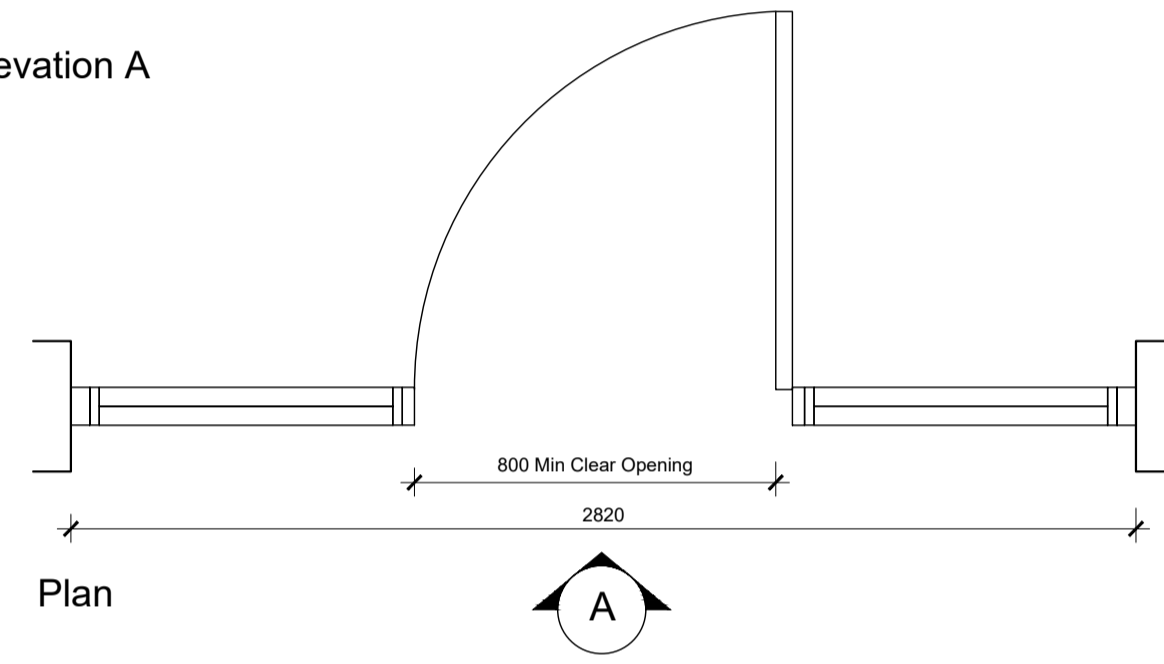

WINDOW TYPE: W2  
WINDOW NUMBERS: W0B.01A

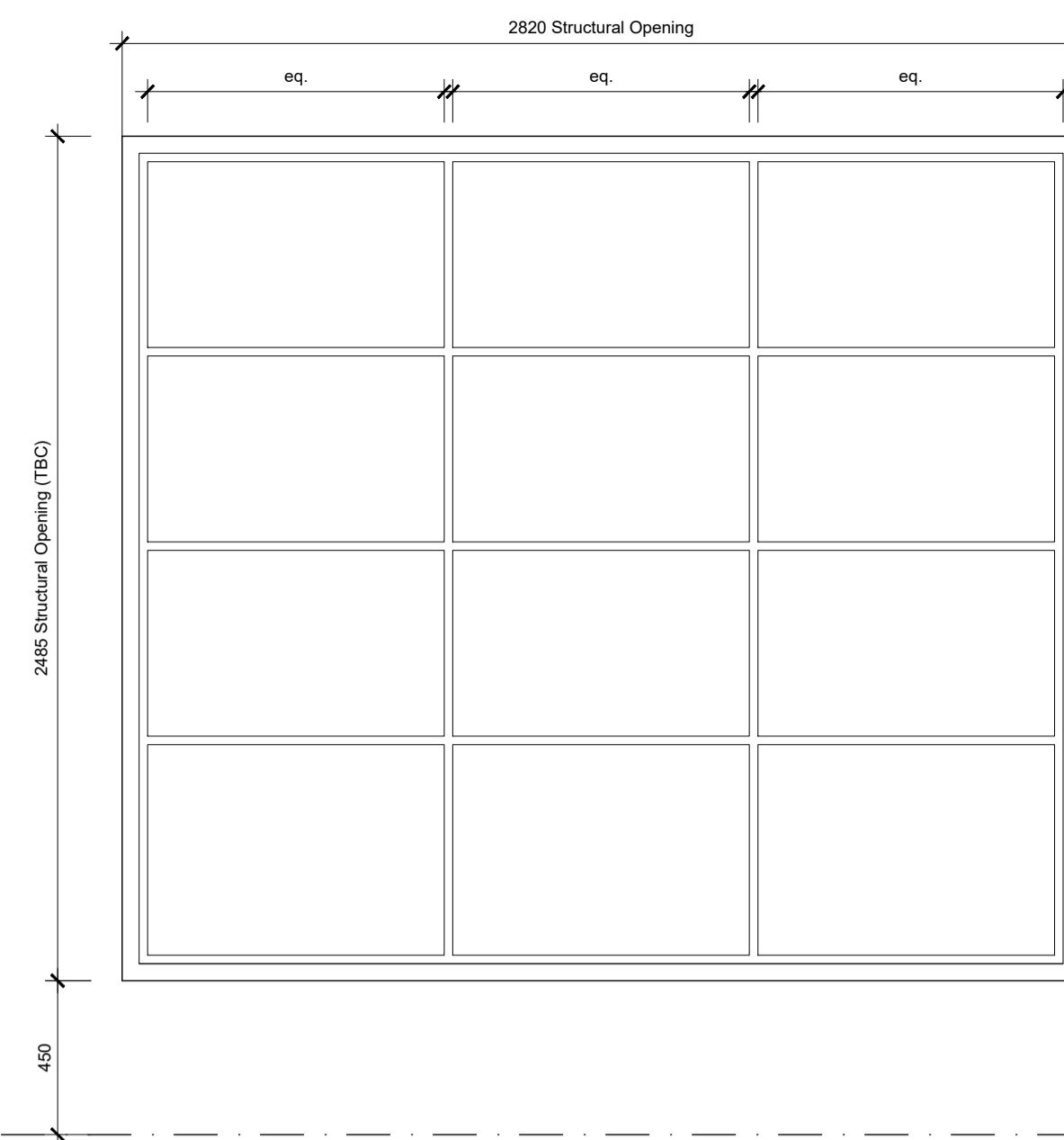

Elevation A

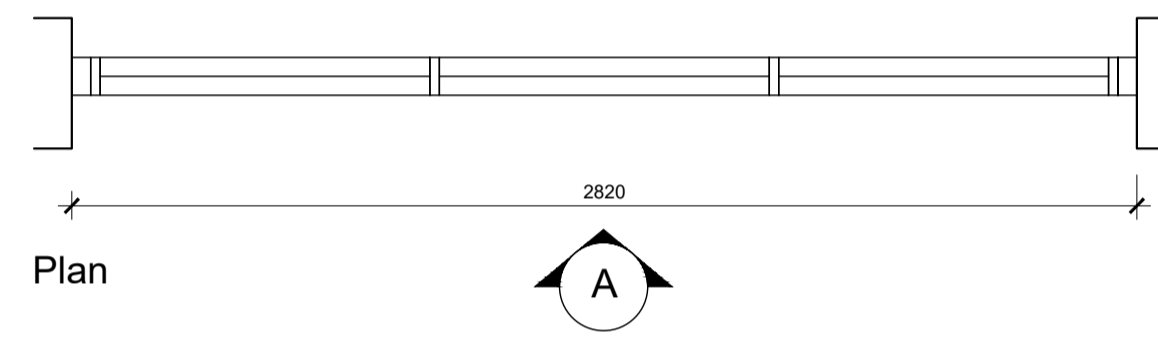

WINDOW TYPE: W3  
WINDOW NUMBERS: W0B.02B

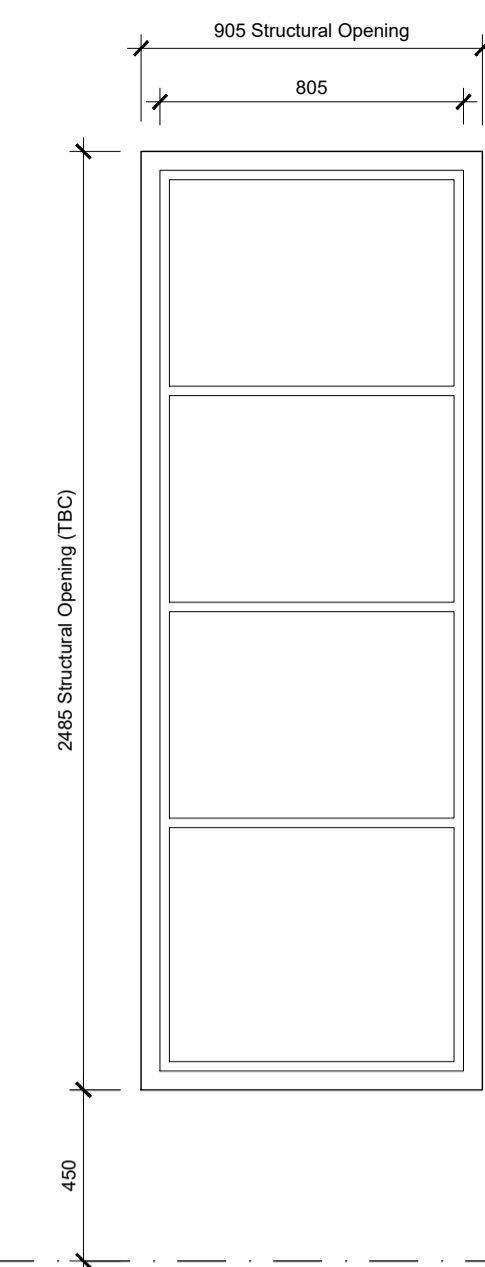

Elevation A

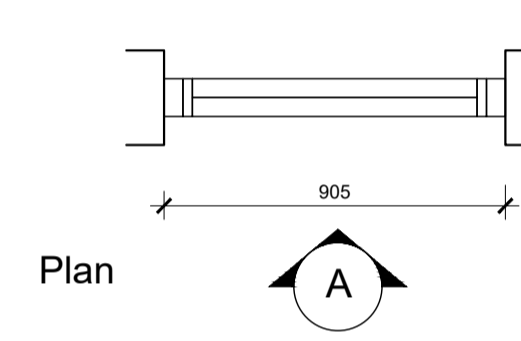

WINDOW TYPE: W4  
WINDOW NUMBERS: W0B.01C

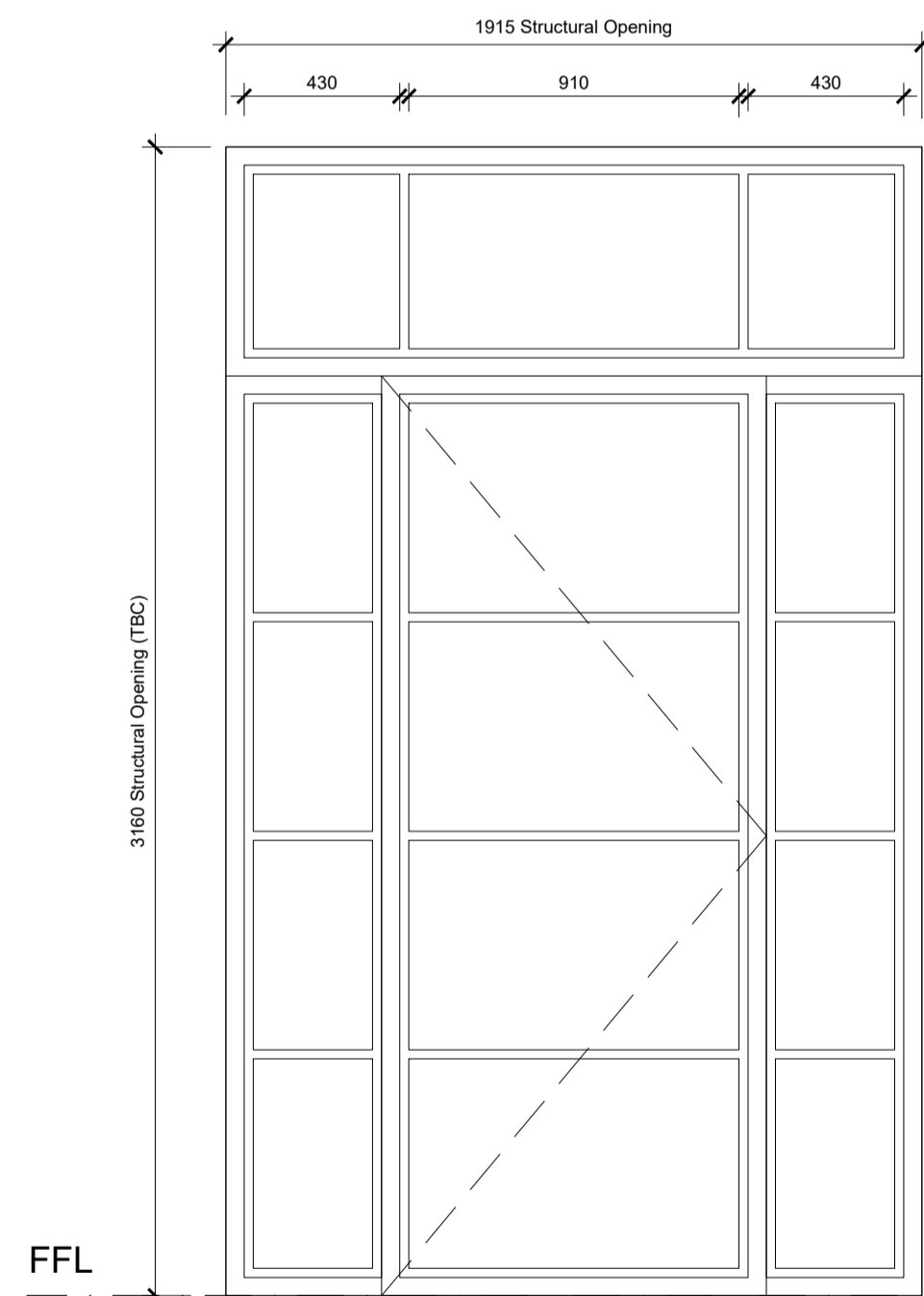

Elevation A

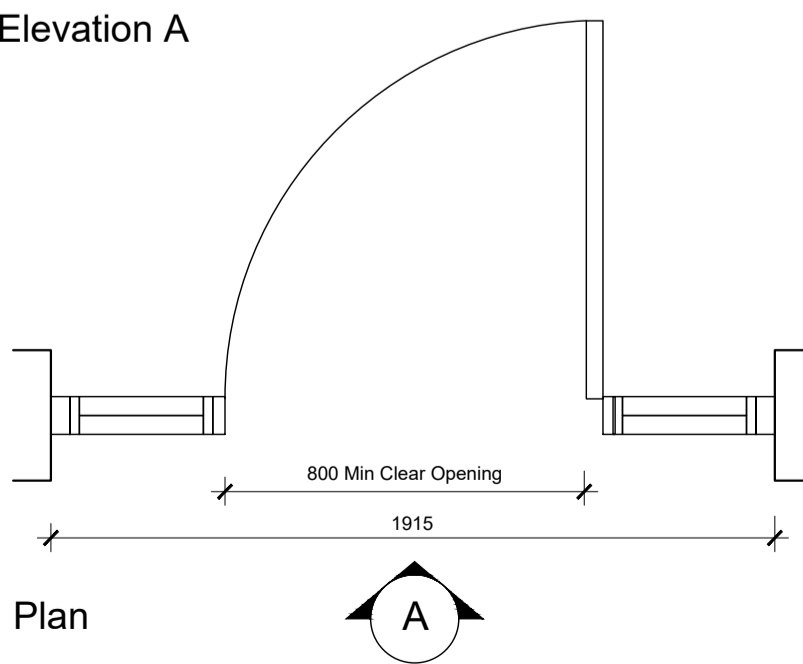

WINDOW TYPE: W5  
WINDOW NUMBERS: W0B.02A

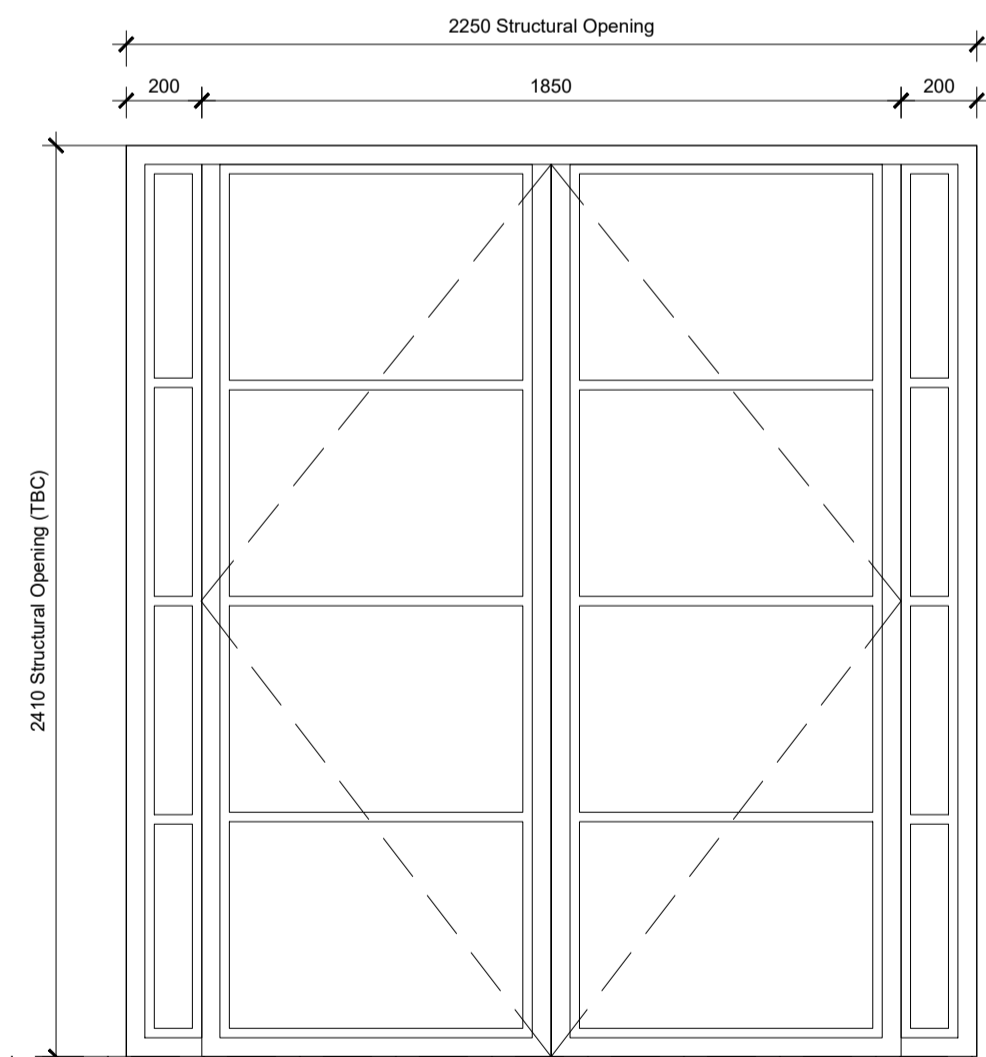

Elevation A

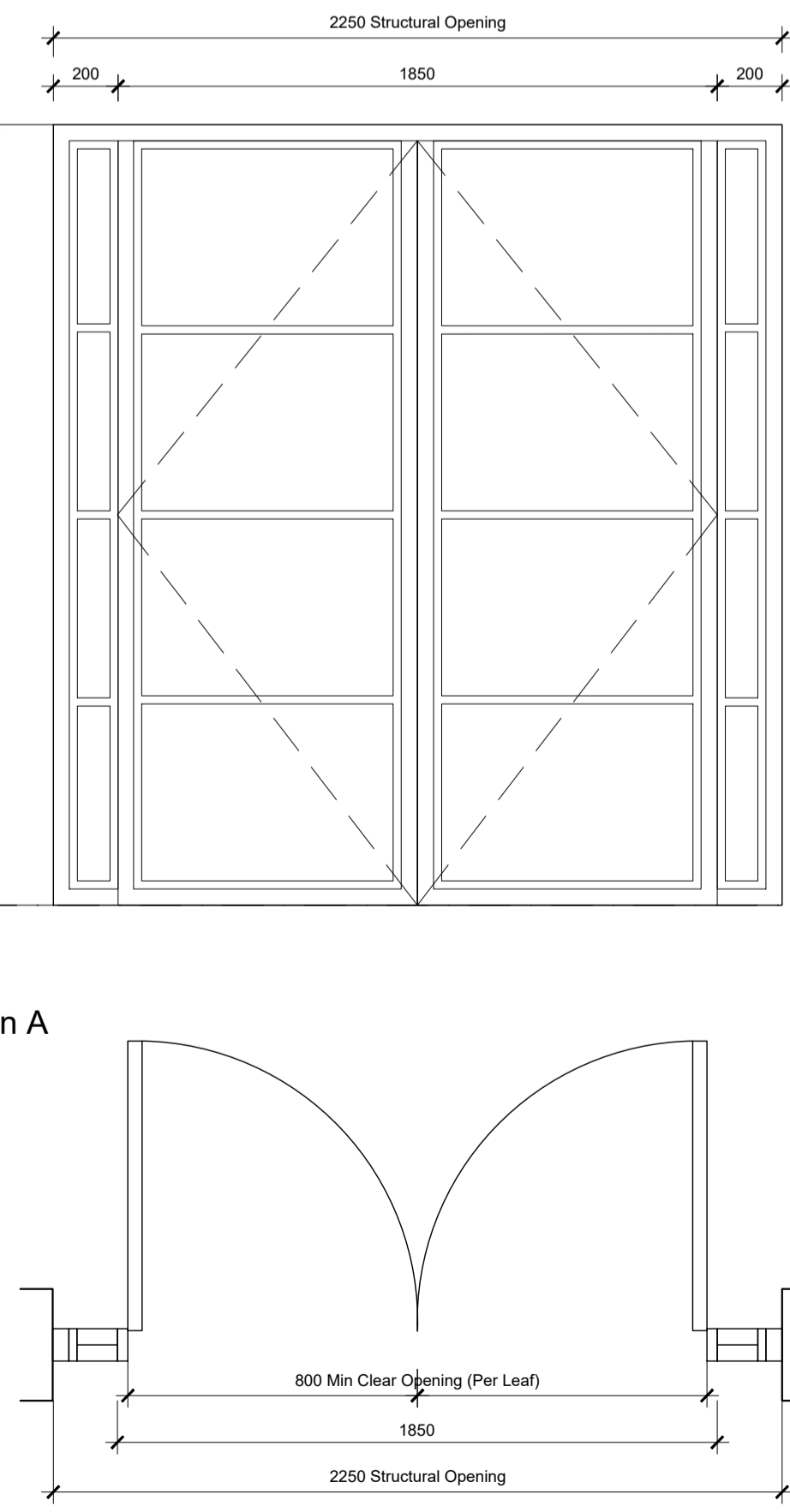

WINDOW TYPE: W6  
WINDOW NUMBERS: W0C.01A

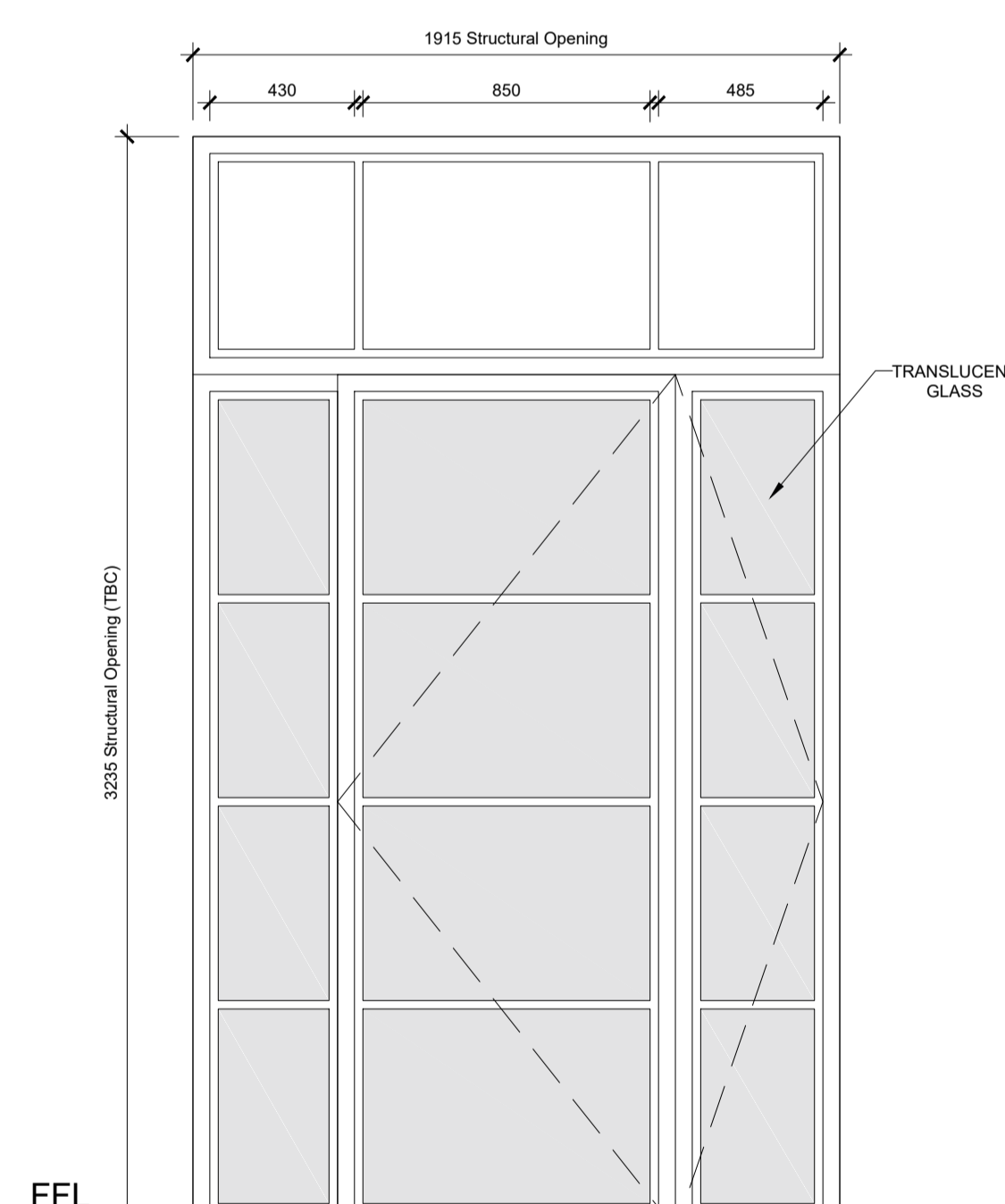

Elevation A

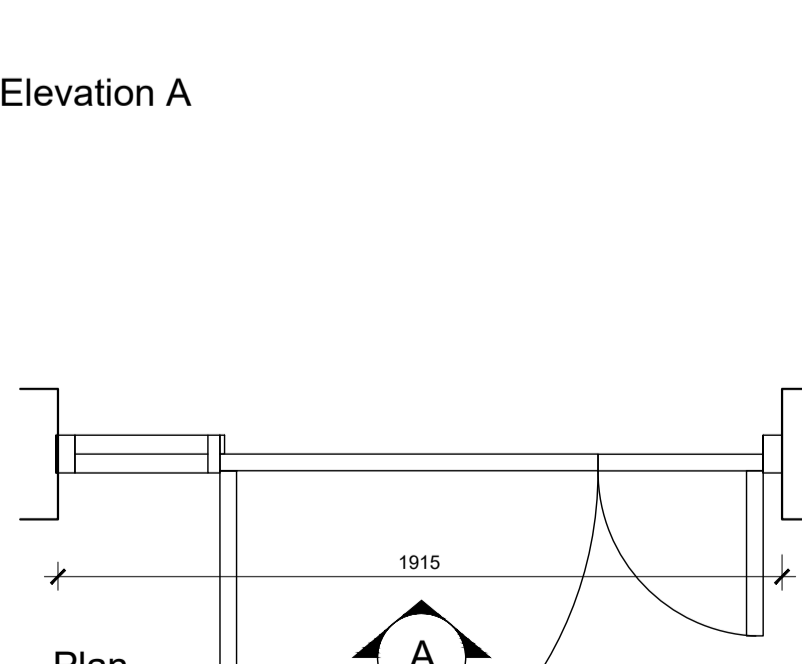

WINDOW TYPE: W7  
WINDOW NUMBERS: W0C.02A

**NOTES**

DO NOT SCALE - USE FIGURED DIMENSIONS ONLY.

ALL DIMENSIONS TO BE CHECKED ON SITE PRIOR TO CONSTRUCTION AND ANY DISCREPANCIES TO BE HIGHLIGHTED BY CONTRACTOR.

THIS DRAWING IS TO BE READ IN CONJUNCTION WITH ALL RELEVANT SPECIFICATIONS AND DRAWINGS.

ALL LEVELS ARE TO FINISHED LEVELS UNLESS OTHERWISE INDICATED.

**LEGEND**

**NOTES**

All windows to achieve a minimum U-Value of 1.4W/m-K

All windows to have black aluminum frames

Doors and windows are to be tested and certified to PAS 24

Trickle vents to be fitted to windows

Ironmongery to be polished chromium plated finish. hinges shall be stainless steel

All windows to have restrictors without removable keys

All windows and doors are to have A or A+ rating in the BRE Green Guide and shall have an appropriate rating by the National Fenestration Registration Council <http://www.nfrc.org/>.

All windows and doors to have a warranty of not less than 10 years.

Glazing:

Laminated glass shall be used for doors and any immediately adjacent glazing in accordance with Part K of the building regulations.

Laminated glass shall be used for the outer panes of all ground floor windows.

All doors to have accessible thresholds in accordance with Part M.

Opening force of main entrance door and doors to commercial units to be in accordance with Part M.

drawing status: **P L A N N I N G**

revision:	description:	date:
PC.01	Issued for Information	30.03.20

**CONSTRUCTION**

**SADAarchitecture**  
P : 26 George Street, St Albans, Hertfordshire, AL3 4ES, UK  
E : letterbox@sada-architecture.com  
W : www.sada-architecture.com  
T : 01727 860810

project: 17-010 - HAMSHIRE STREET  
drawing: WINDOW SCHEDULE (Sheet 1 of 4)  
date: 21-08-17 drawn by: DG check: CC  
scale: 1:20 @ A1 drwg no.: 1220 rev. no.: C.01  
© Copyright: This drawing or design may not be reproduced without permission.

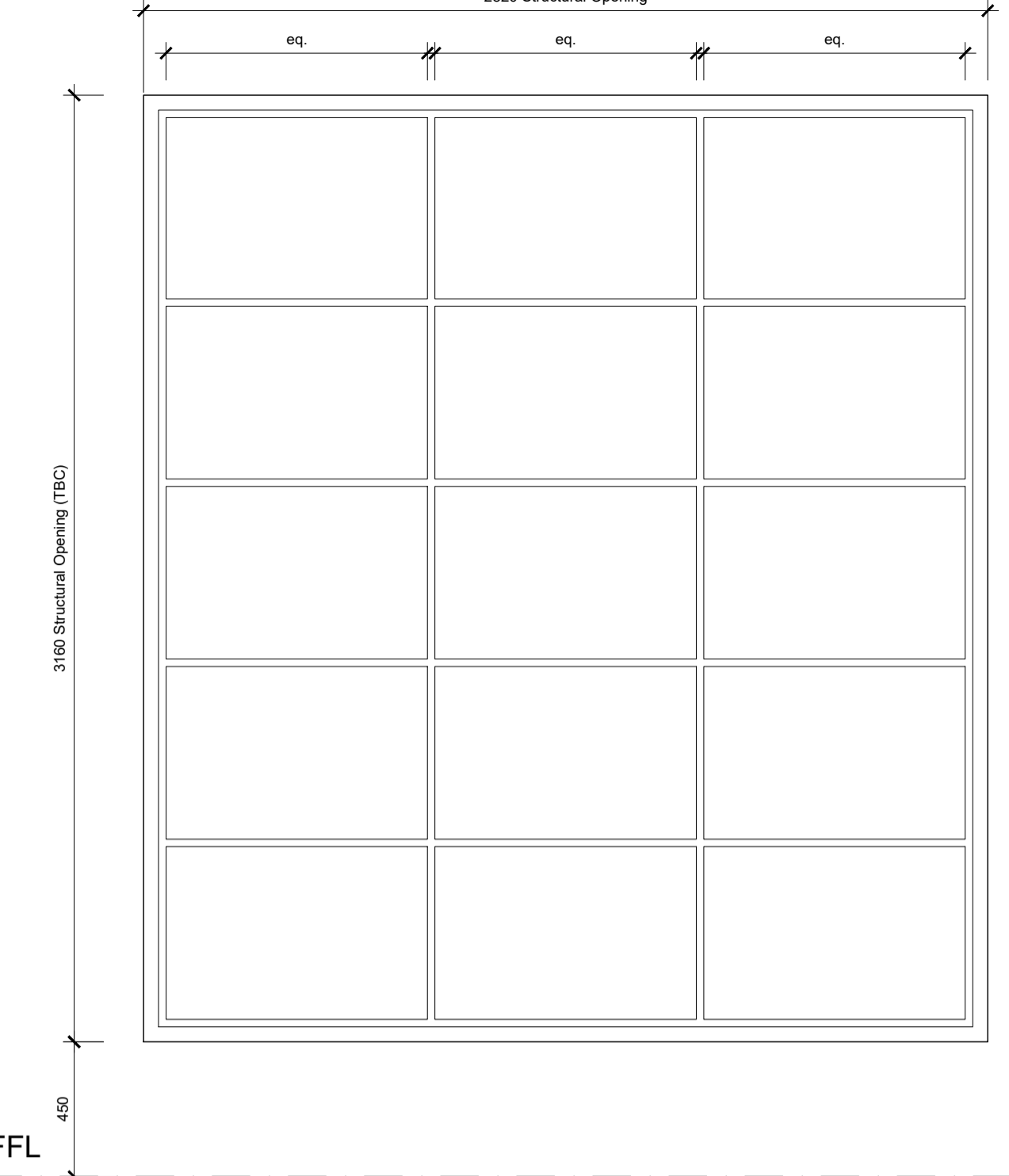

Elevation A

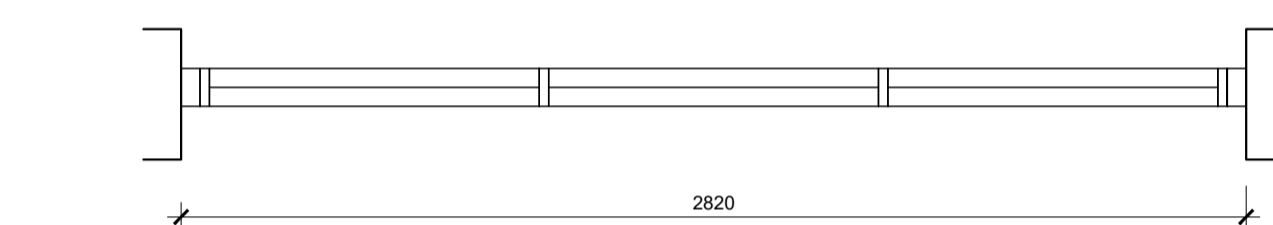

Plan  
WINDOW TYPE: W8  
WINDOW NUMBERS: W0B.03c

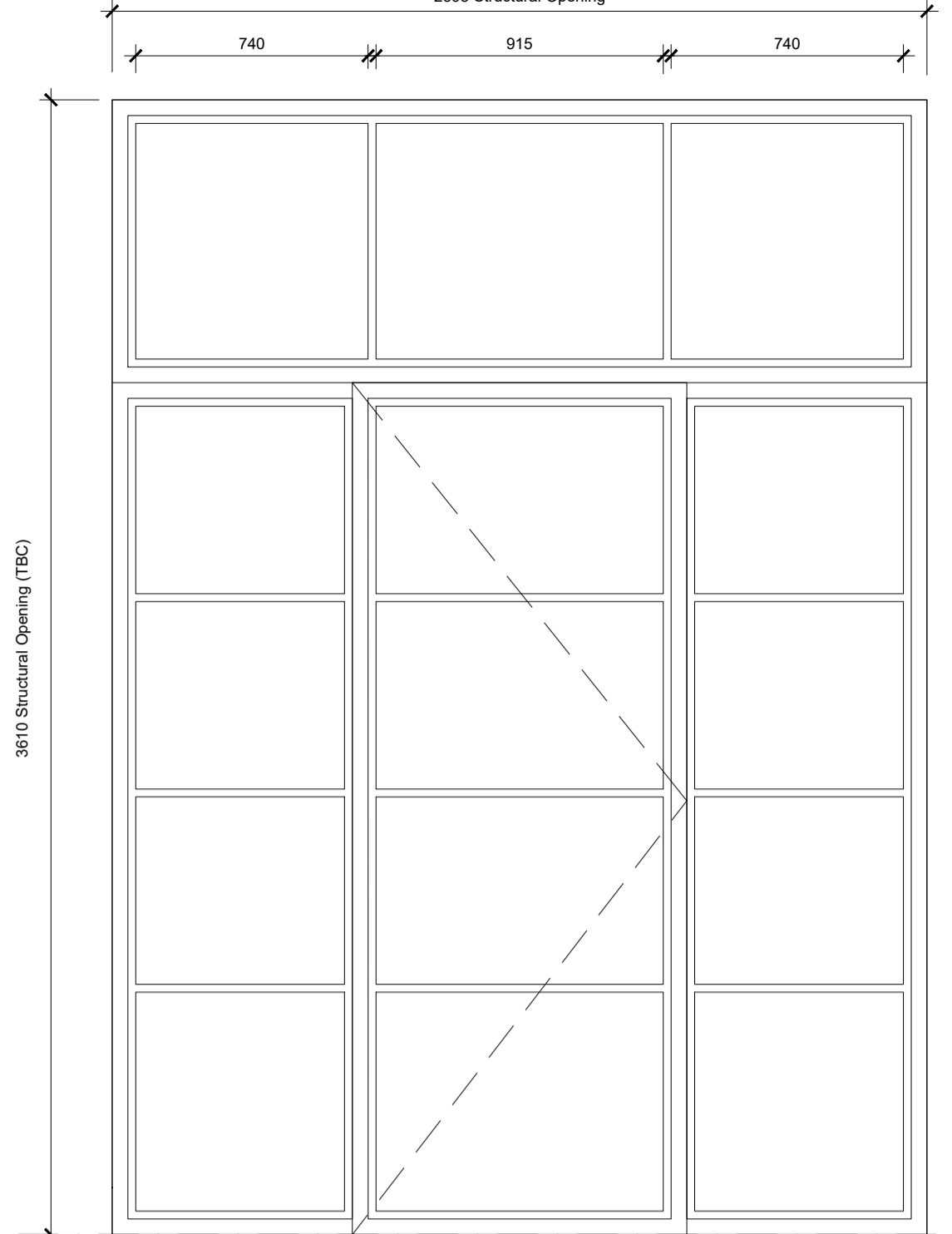

Elevation A

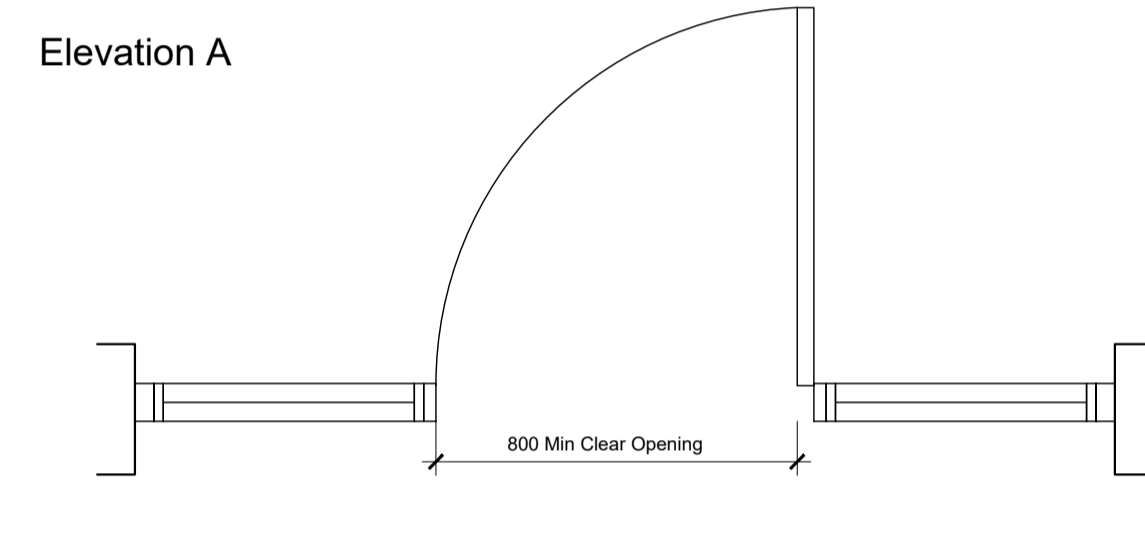

Plan  
WINDOW TYPE: W9  
WINDOW NUMBERS: W0B.03b

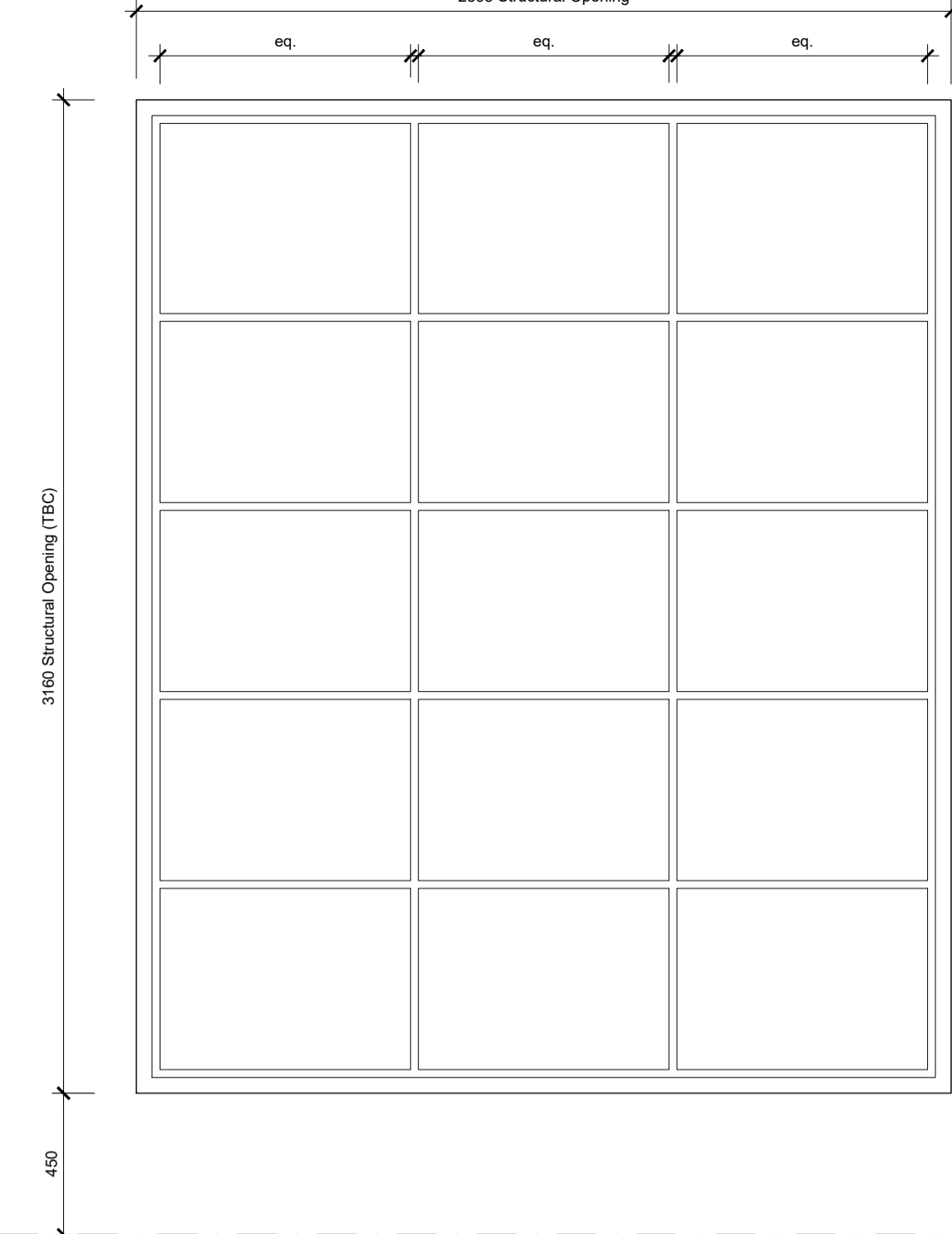

Elevation A

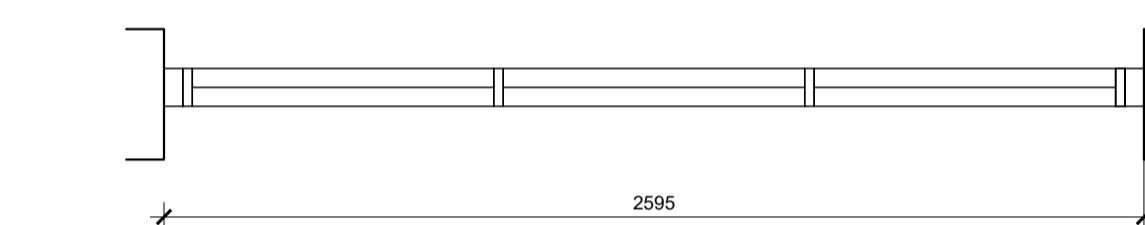

Plan  
WINDOW TYPE: W10  
WINDOW NUMBERS: W0B.03a

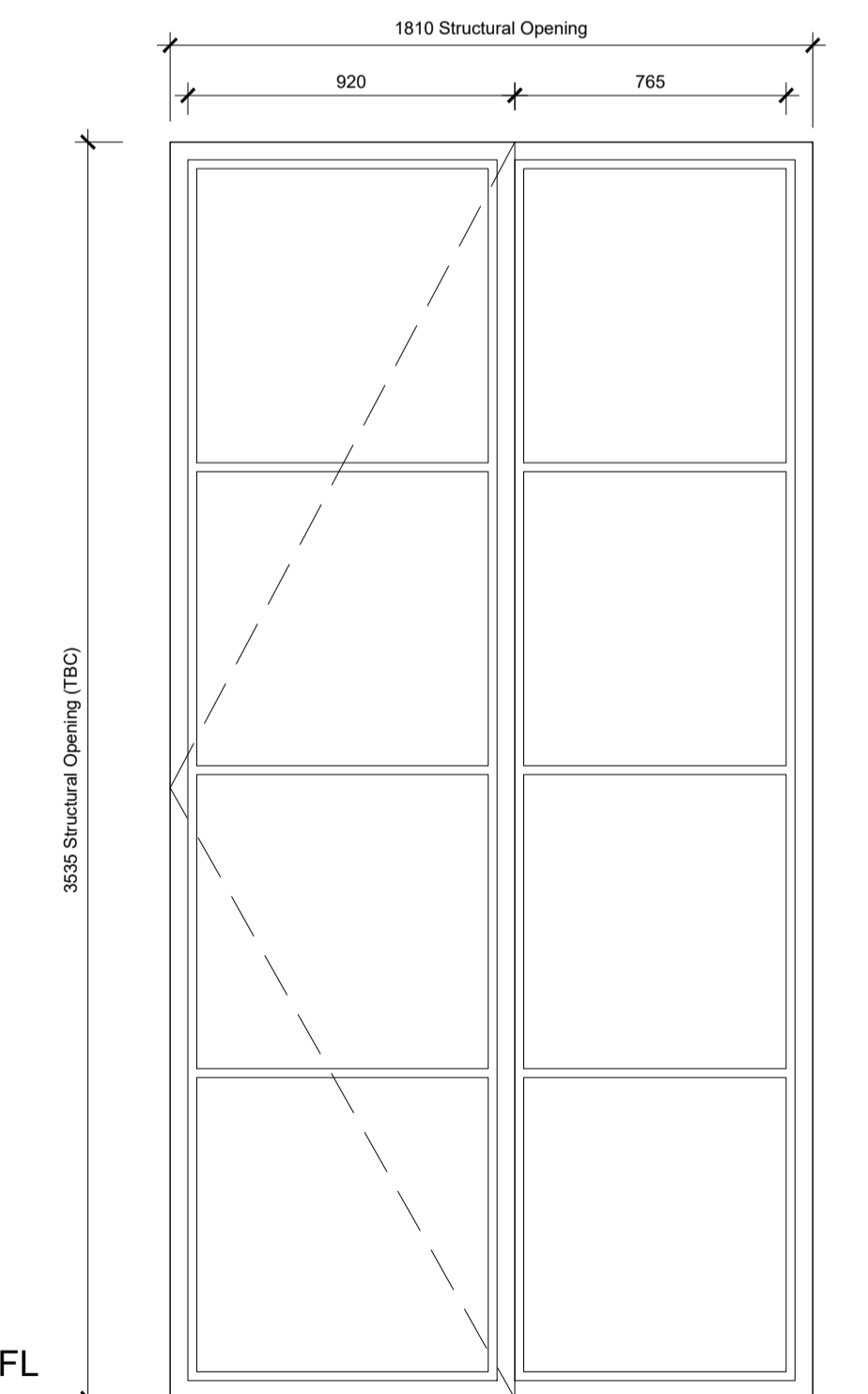

Elevation A

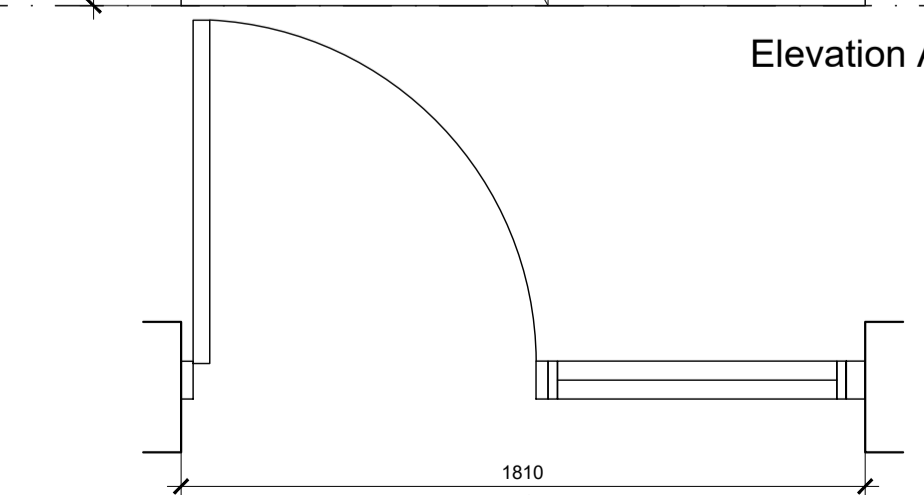

Plan  
WINDOW TYPE: W11  
WINDOW NUMBERS: W0B.03e

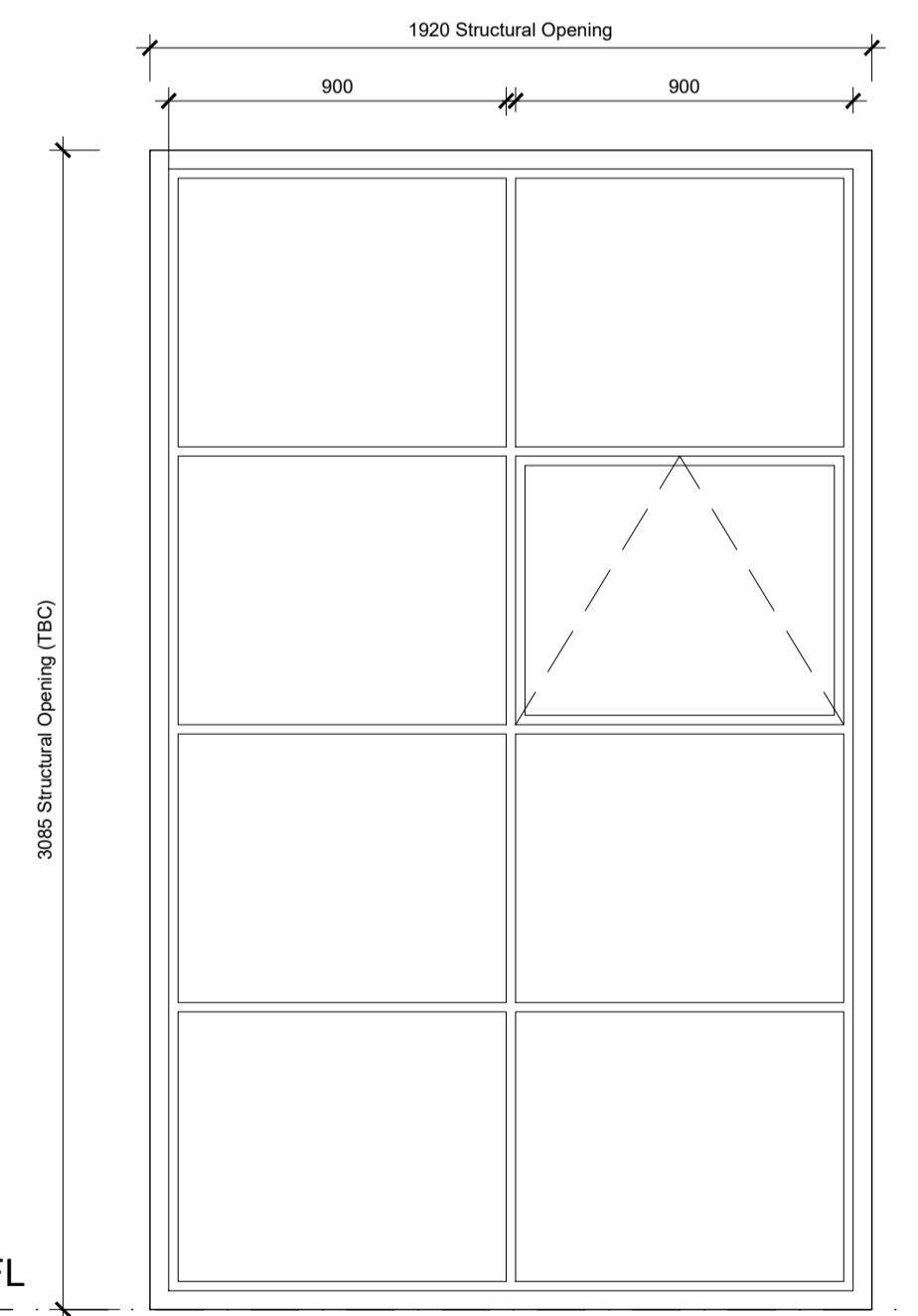

Elevation A

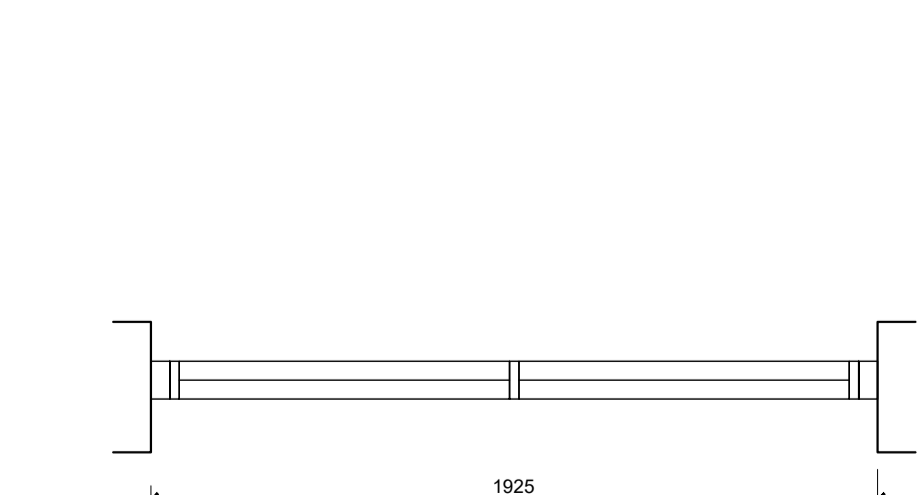

Plan  
WINDOW TYPE: W12  
WINDOW NUMBERS: W0B.02c

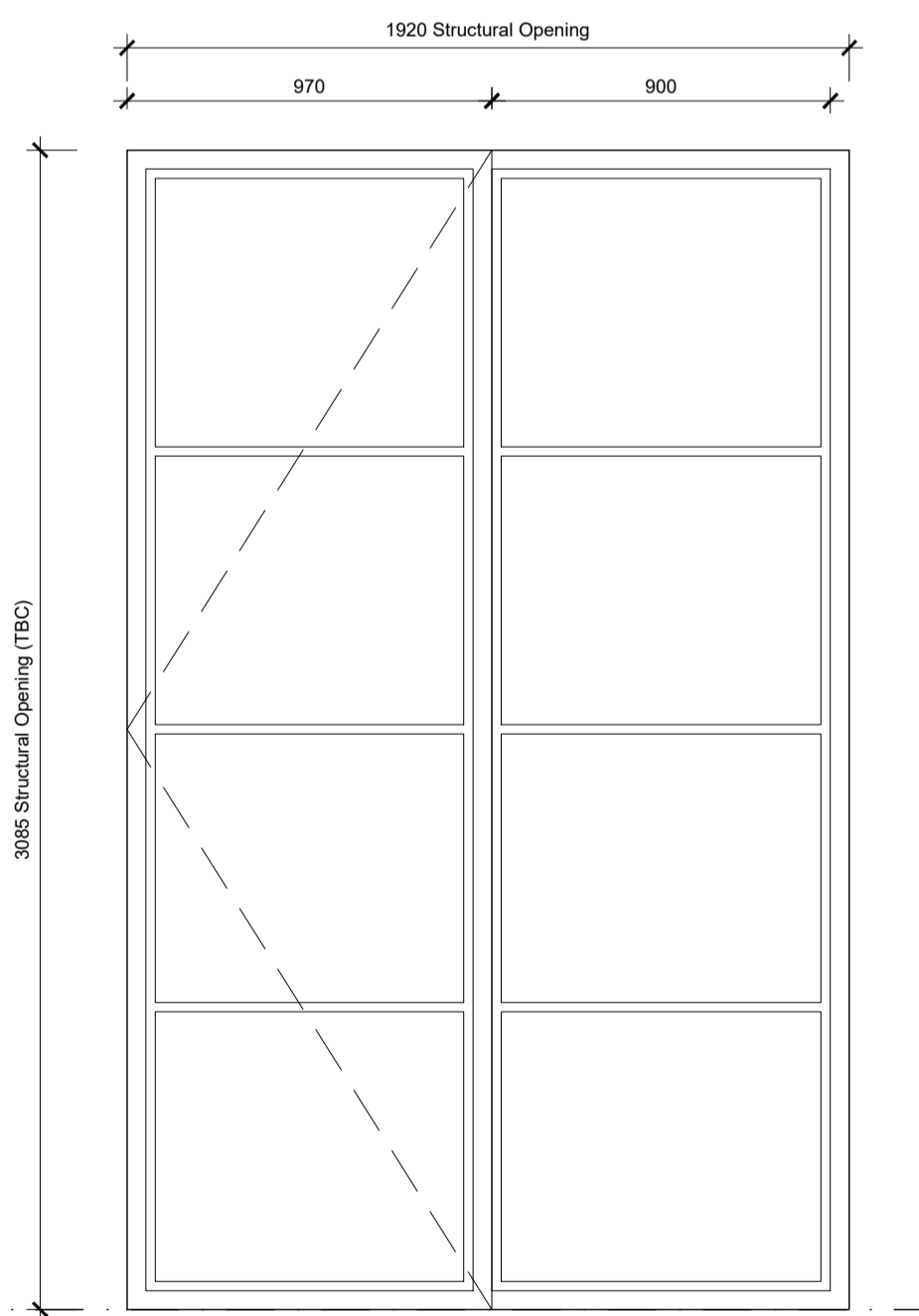

Elevation A

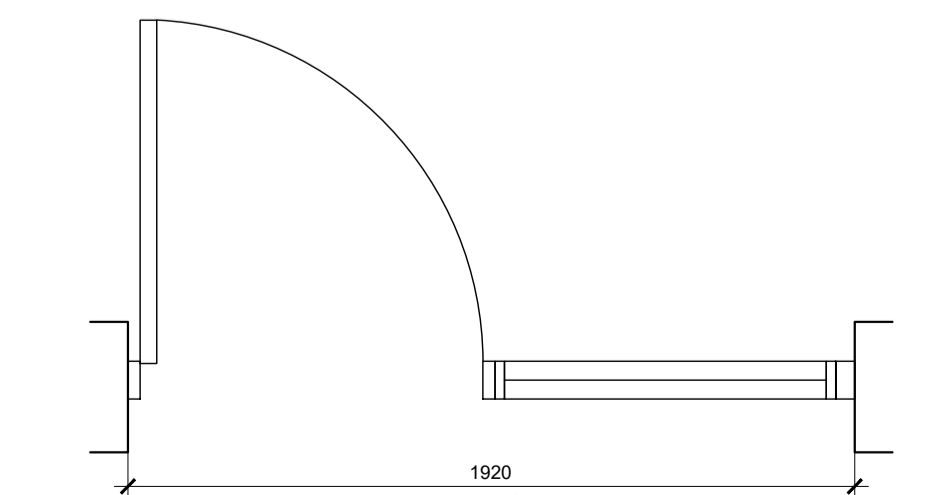

Plan  
WINDOW TYPE: W13  
WINDOW NUMBERS: W0B.02d

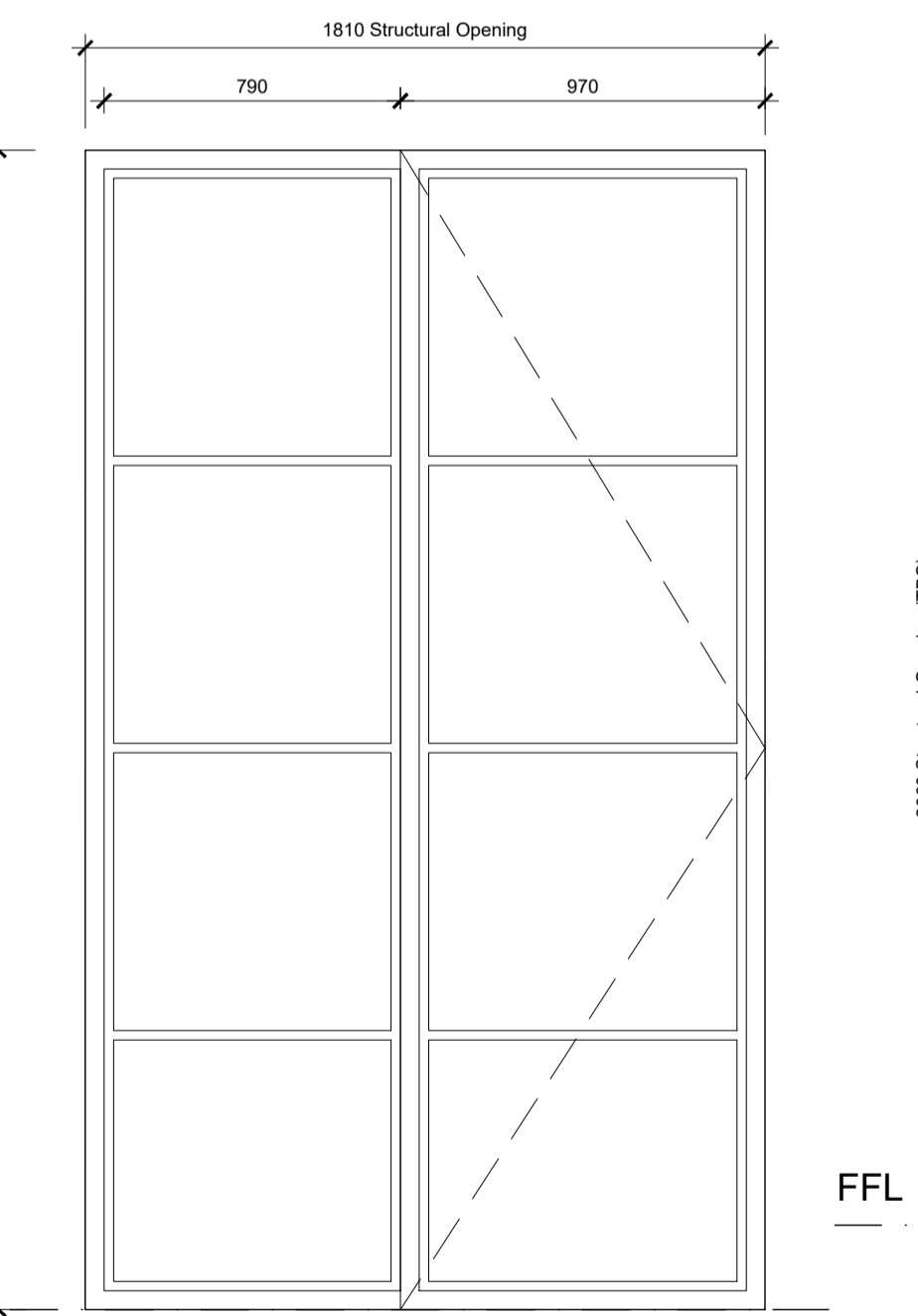

Elevation A

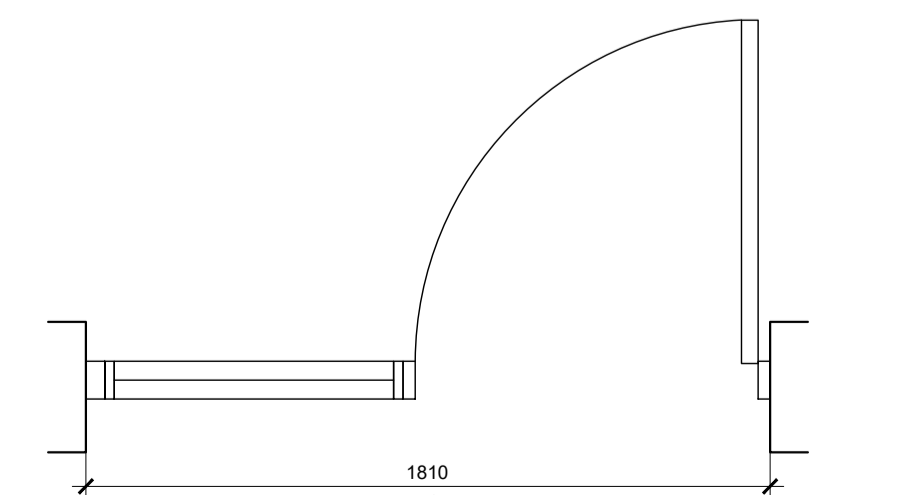

Plan  
WINDOW TYPE: W14  
WINDOW NUMBERS: W0C.01b

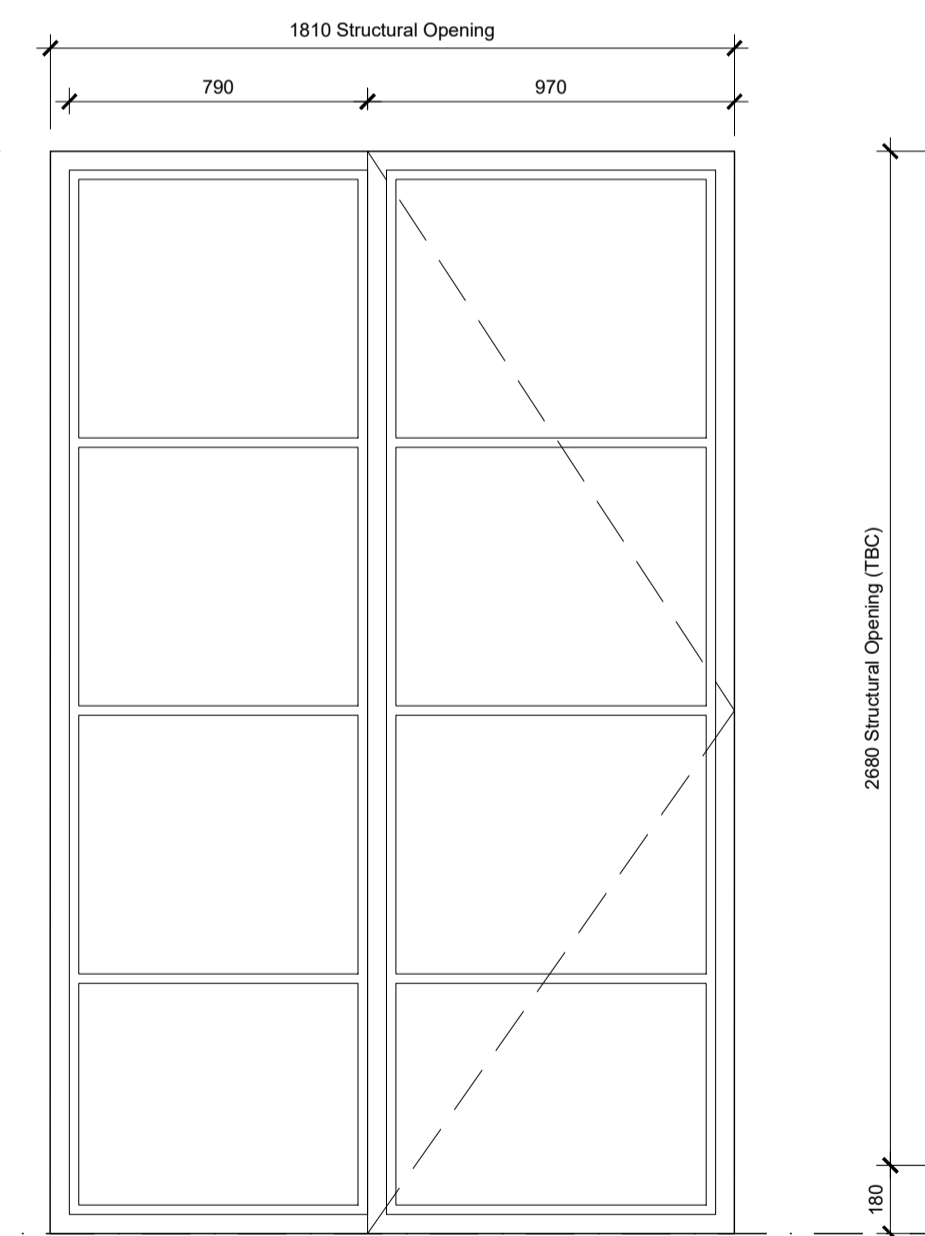

Elevation A

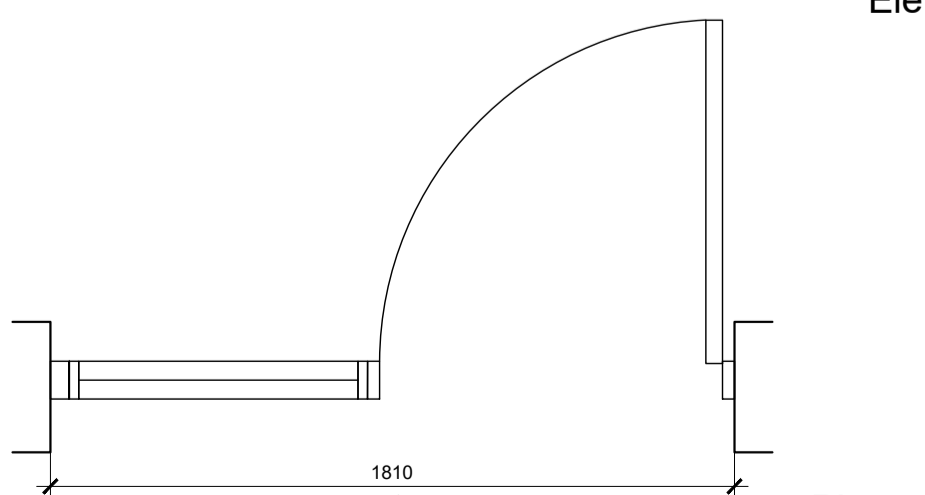

Plan  
WINDOW TYPE: W15  
WINDOW NUMBERS: W0B.01e

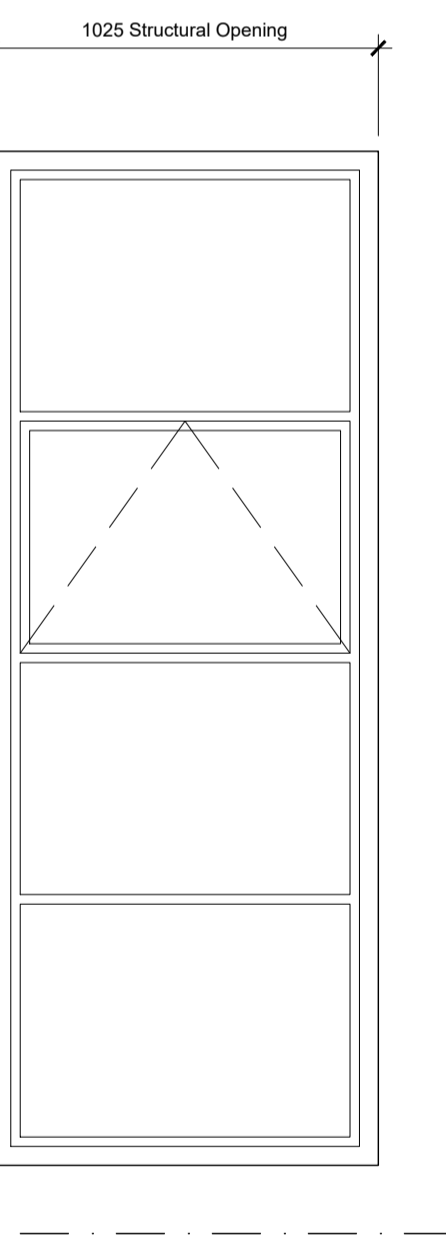

Elevation A

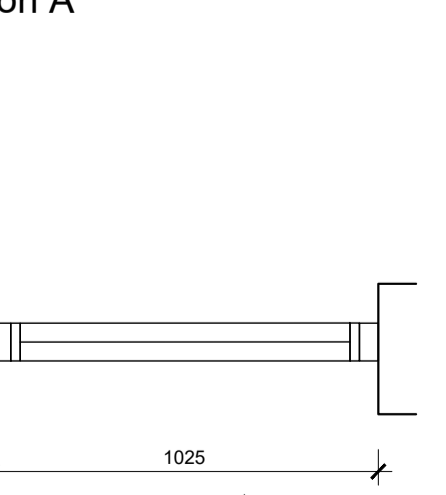

Plan  
WINDOW TYPE: W16  
WINDOW NUMBERS: W0B.03d, W0B.01D

**NOTES**

DO NOT SCALE - USE FIGURED DIMENSIONS ONLY.

ALL DIMENSIONS TO BE CHECKED ON SITE PRIOR TO CONSTRUCTION AND ANY DISCREPANCIES TO BE HIGHLIGHTED BY CONTRACTOR.

THIS DRAWING IS TO BE READ IN CONJUNCTION WITH ALL RELEVANT SPECIFICATIONS AND DRAWINGS.

ALL LEVELS ARE TO FINISHED LEVELS UNLESS OTHERWISE INDICATED.

**LEGEND**

**NOTES**

- All windows to achieve a minimum U-Value of 1.4W/m-K
- All windows to have black aluminum frames
- Doors and windows are to be tested and certified to PAS 24
- Trickle vents to be fitted to windows
- Ironmongery to be polished chromium plated finish. hinges shall be stainless steel
- All windows to have restrictors without removable keys
- All windows and doors are to have A or A+ rating in the BRE Green Guide and shall have an appropriate rating by the National Fenestration Registration Council <http://www.nfrc.org/>.
- All windows and doors to have a warranty of not less than 10 years.
- Glazing: Laminated glass shall be used for doors and any immediately adjacent glazing in accordance with Part K of the building regulations. Laminated glass shall be used for the outer panes of all ground floor windows.
- All doors to have accessible thresholds in accordance with Part M.
- Opening force of main entrance door and doors to commercial units to be in accordance with Part M.

drawing status: **P L A N N I N G**

revision:	description:	date:
PC.01	Issued for Information	30.03.20

**CONSTRUCTION**

**SADA**architecture  
 P : 26 George Street, St Albans, Hertfordshire, AL3 4ES, UK  
 E : letterbox@sada-architecture.com  
 W : www.sada-architecture.com  
 T : 01727 860810

project: 17-010 - HAMSHIRE STREET  
 drawing: WINDOW SCHEDULE (Sheet 2 of 4)  
 date: 21-08-17 drawn by: DG check: CC  
 scale: 1:20 @ A1 drwg no.: 1221 rev. no.: C.01  
 © Copyright: This drawing or design may not be reproduced without permission.

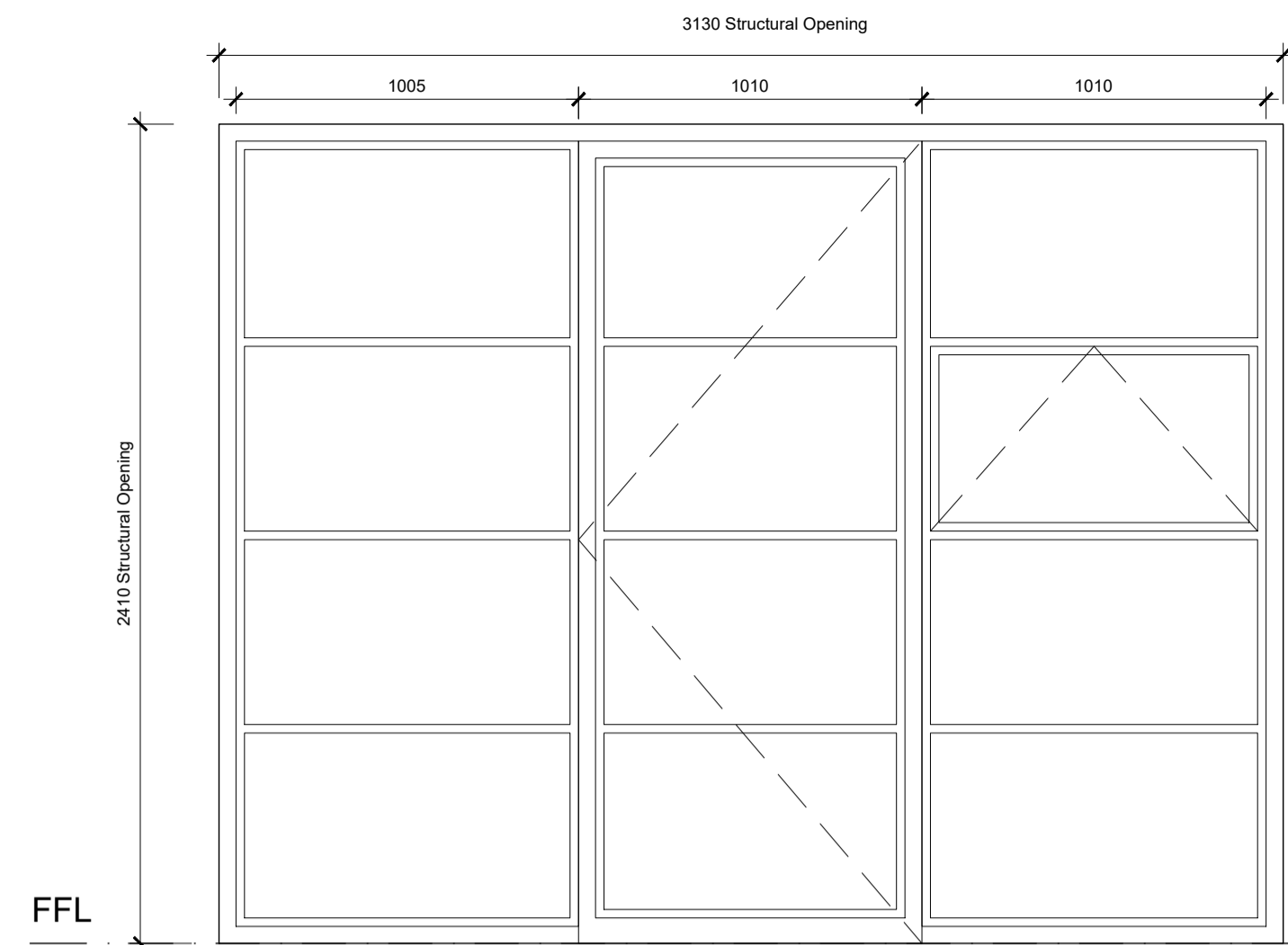

Elevation A

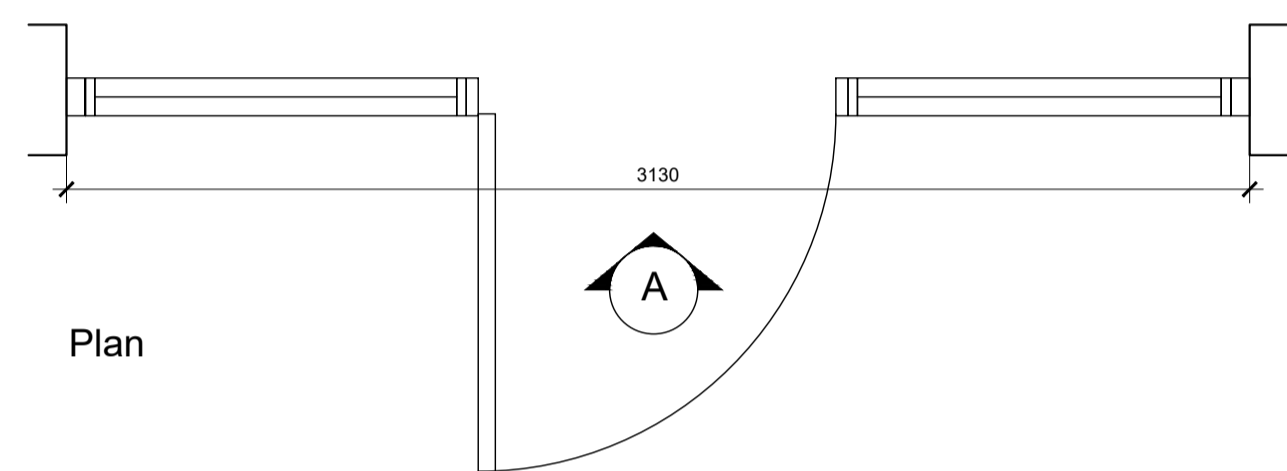

Plan

WINDOW TYPE: W17

WINDOW NUMBERS: W1A.01A, W2A.07A

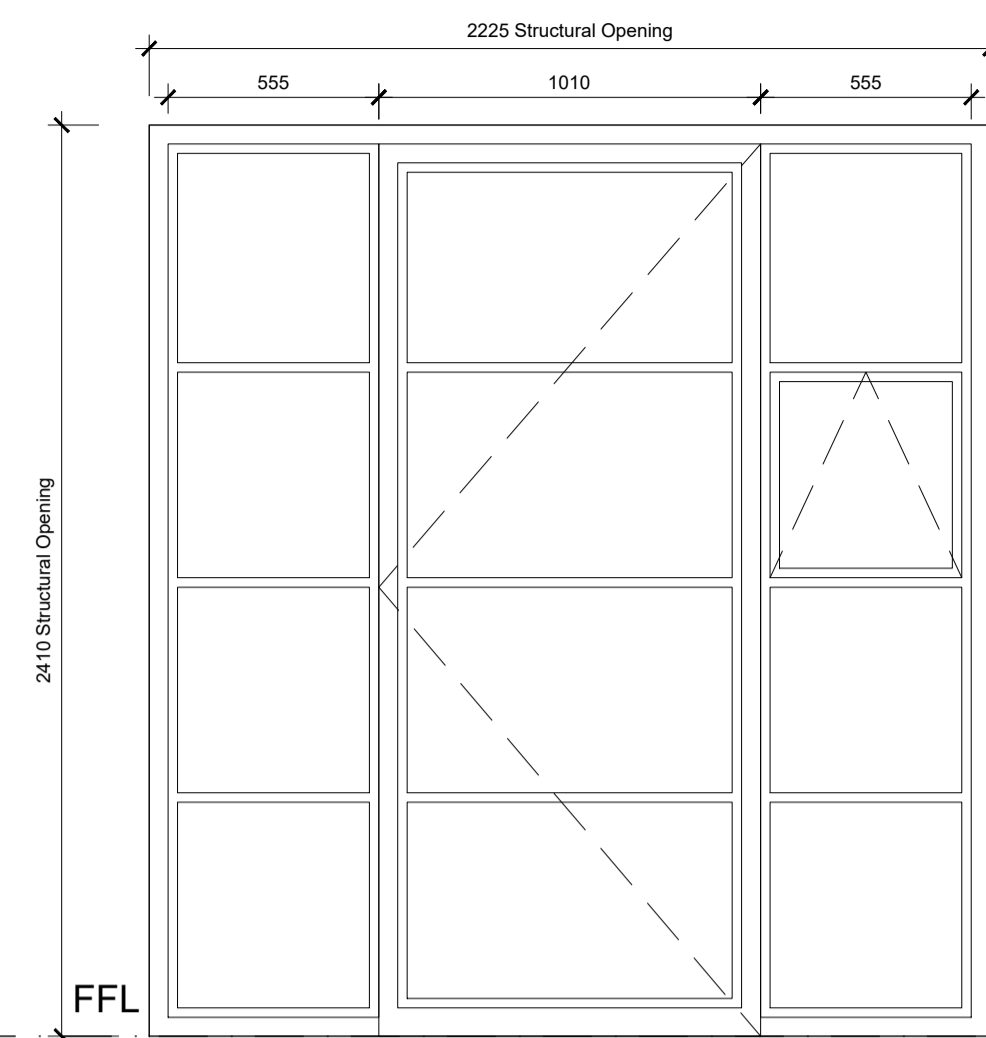

Elevation A

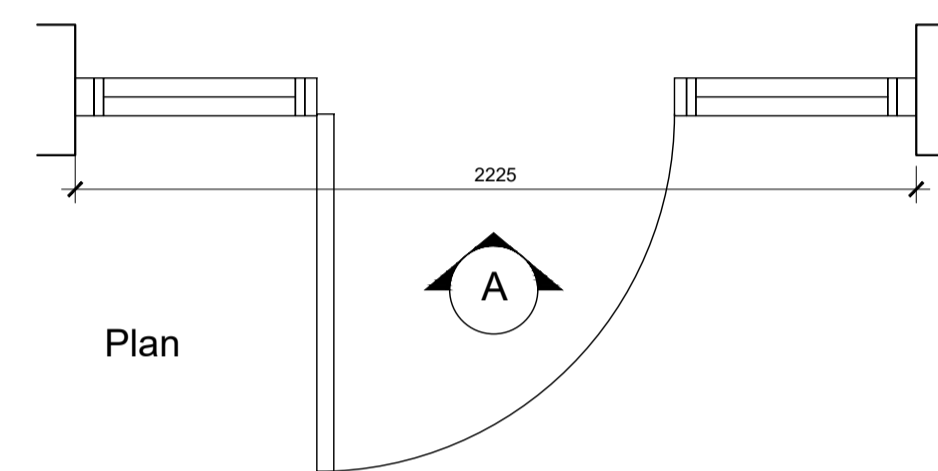

Plan

WINDOW TYPE: W18

WINDOW NUMBERS: W1A.02B, W2A.08B  
MIRROR IMAGE: W01A.06B, W2A.12A

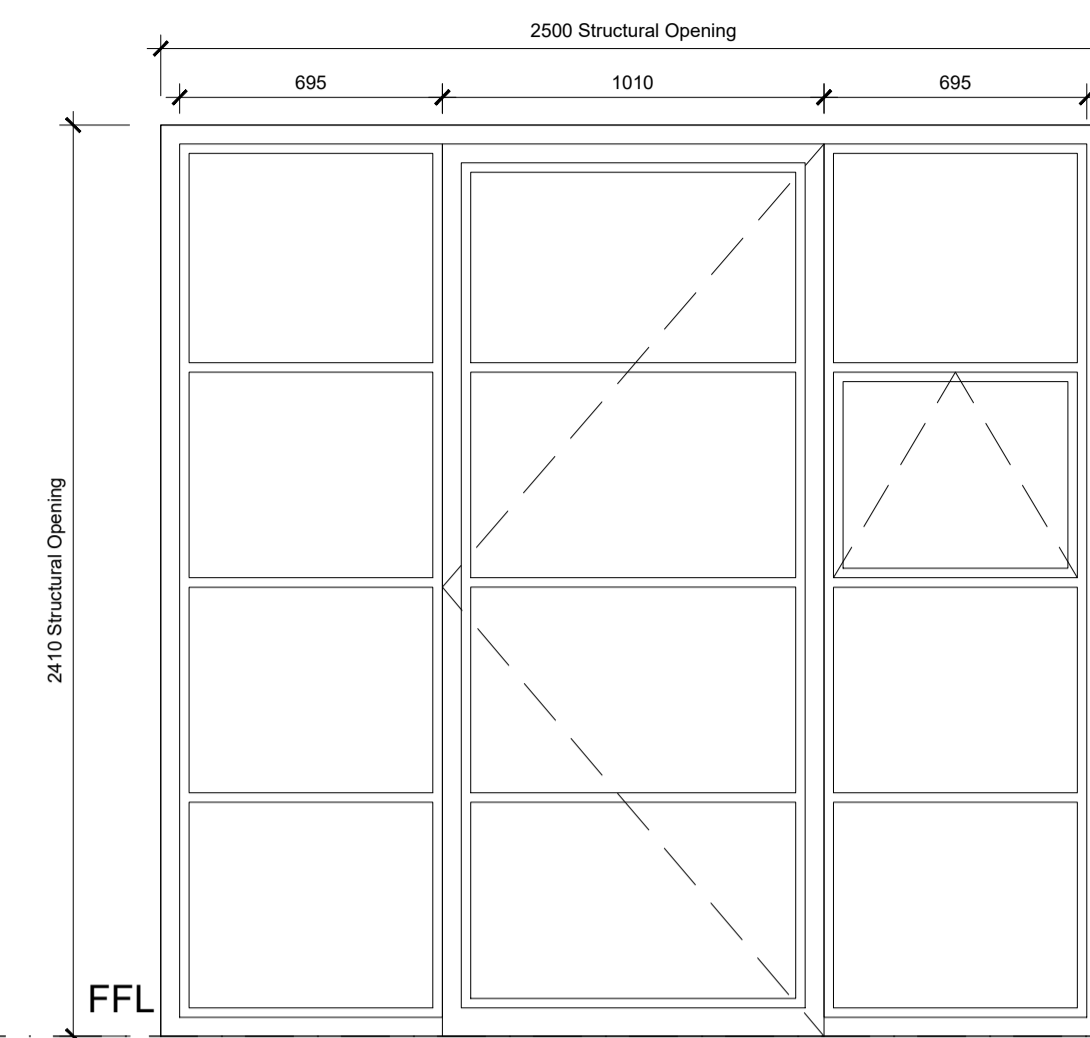

Elevation A

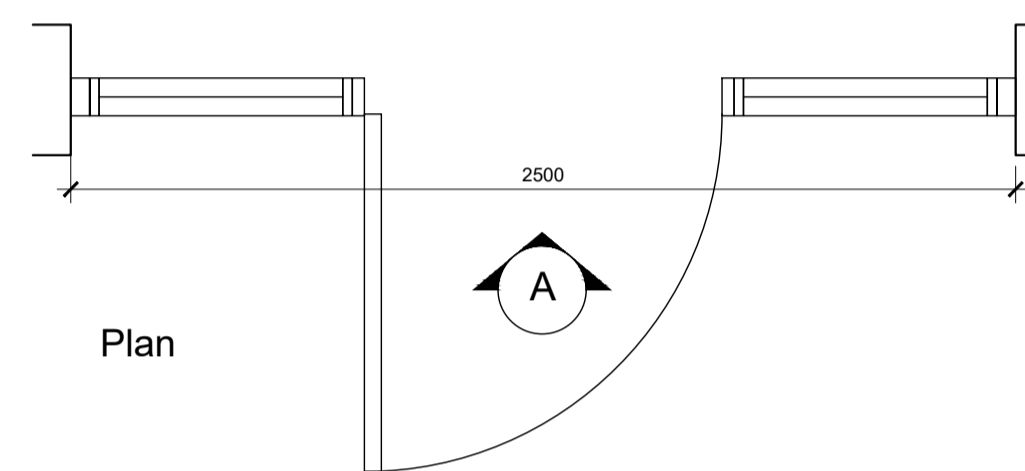

Plan

WINDOW TYPE: W19

WINDOW NUMBERS: W1A.05A, W1A.06A, W2A.11A, W2A.12B  
MIRROR IMAGE: W1A.02A, W2A.08A

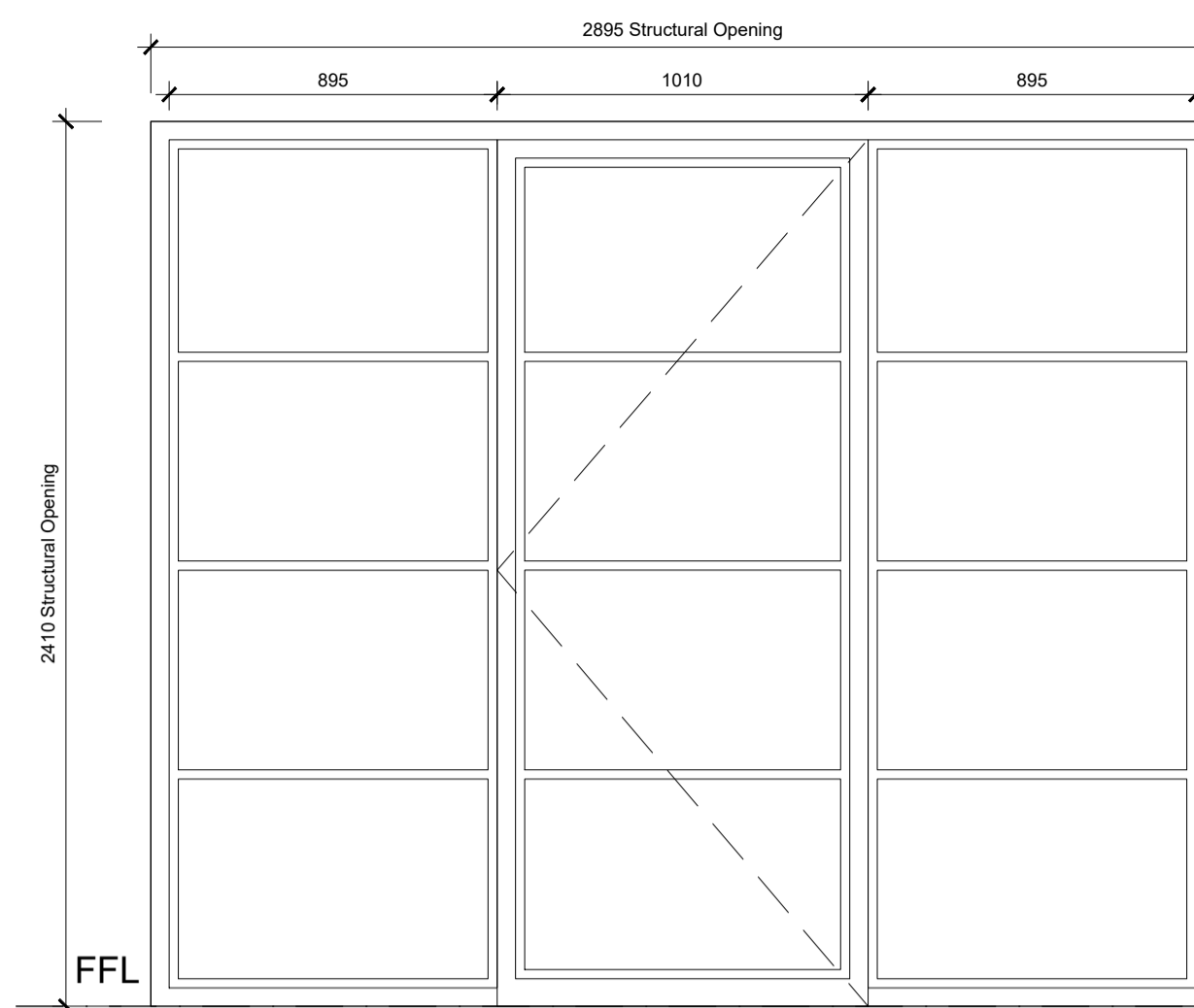

Elevation A

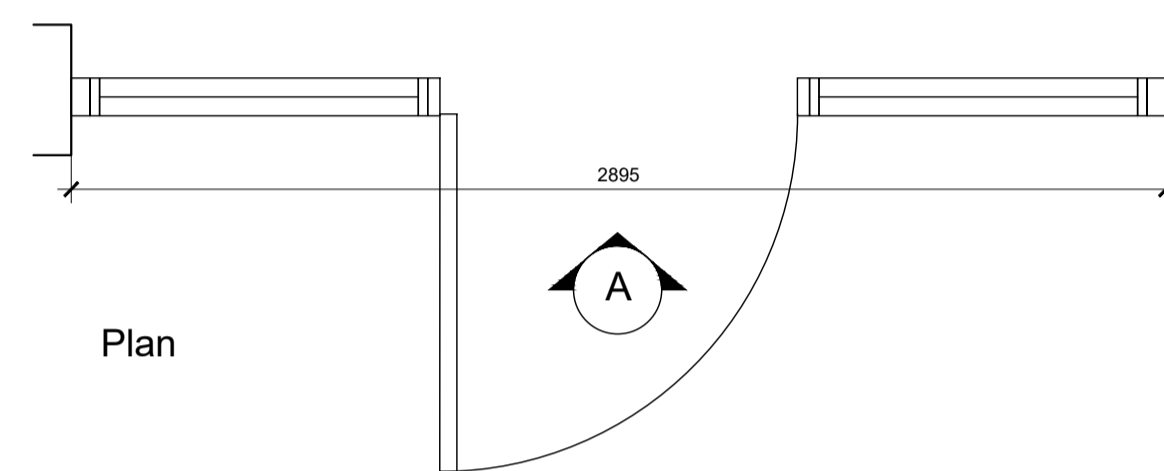

Plan

WINDOW TYPE: W20

WINDOW NUMBERS: W1A.03A, W2A.09A  
MIRROR IMAGE: W1A.04A, W2A.10A

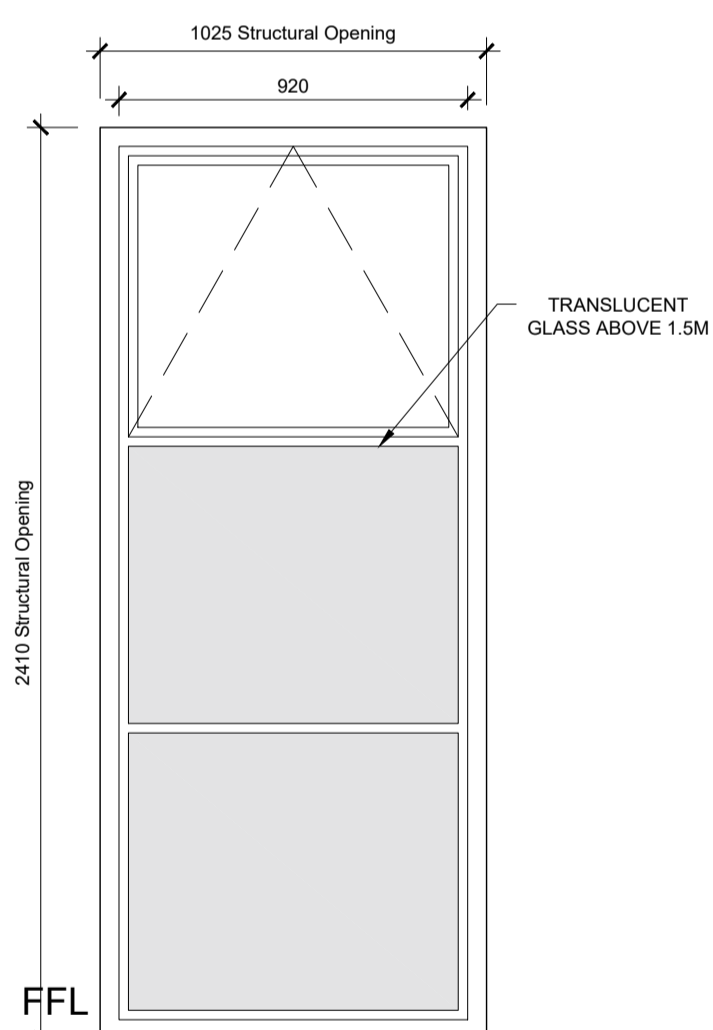

Elevation A

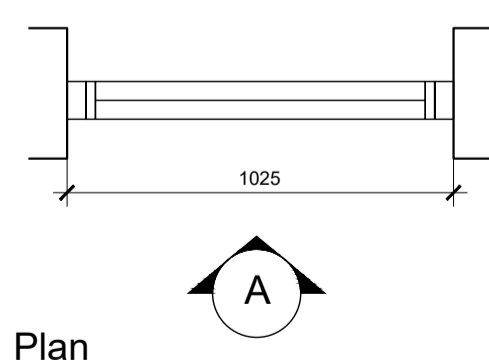

Plan

WINDOW TYPE: W21

WINDOW NUMBERS: W1A.05B, W1A.04B, W1A.3B, W1A.02C, W2A.11B, W2A.10B, W2A.09B, W2A.08C, W3A.15E, W3A.15D, W3A.14D, W3A.14C, W3A.13D

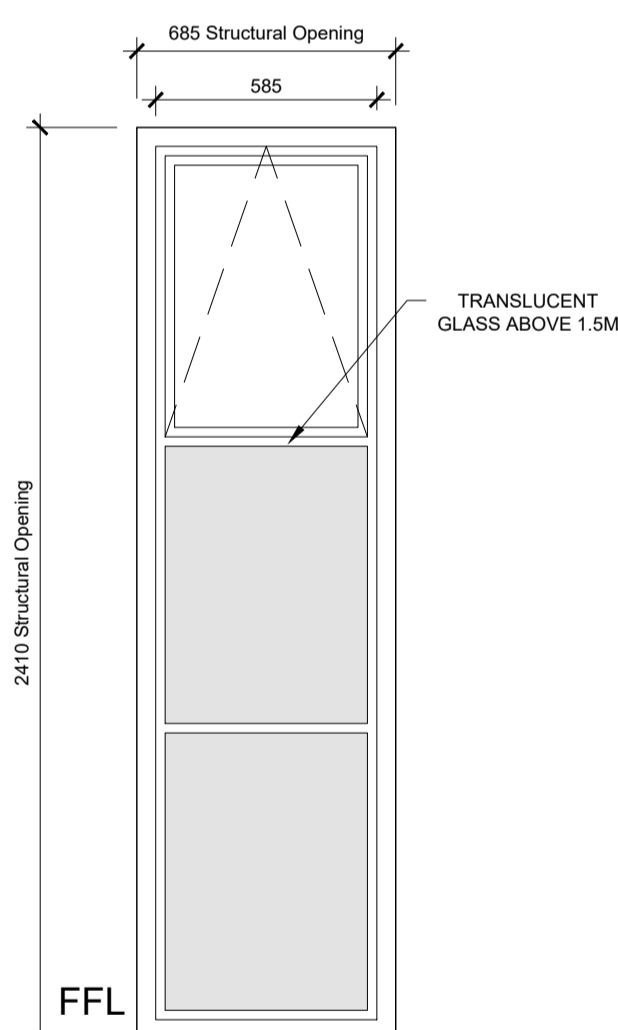

Elevation A

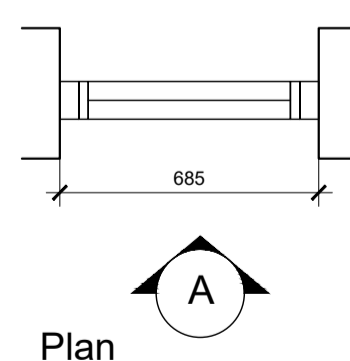

Plan

WINDOW TYPE: W22

WINDOW NUMBERS: W1A.06D, W1A.01C, W2A.12D, W2A.07C, W3A.16D

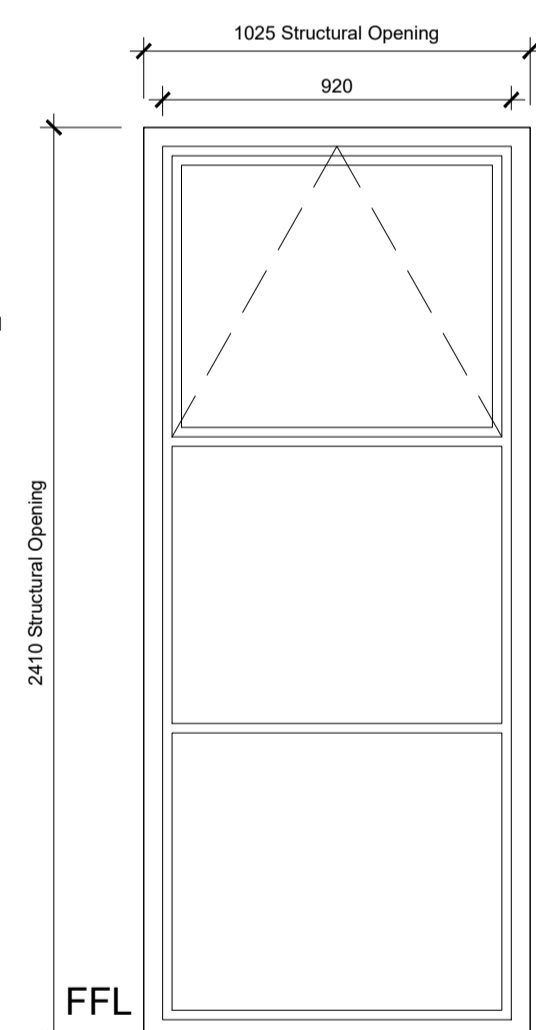

Elevation A

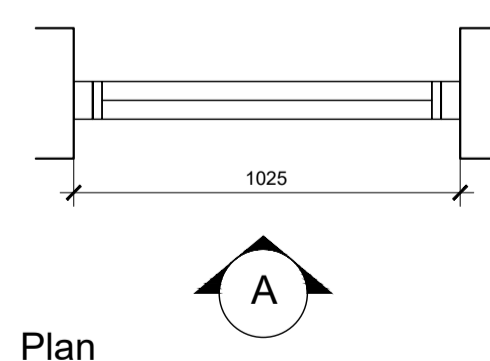

Plan

WINDOW TYPE: W23

WINDOW NUMBERS: W1A.06C, W1A.01B, W2A.12C, W2A.07B, W3A.16C, W3A.13C

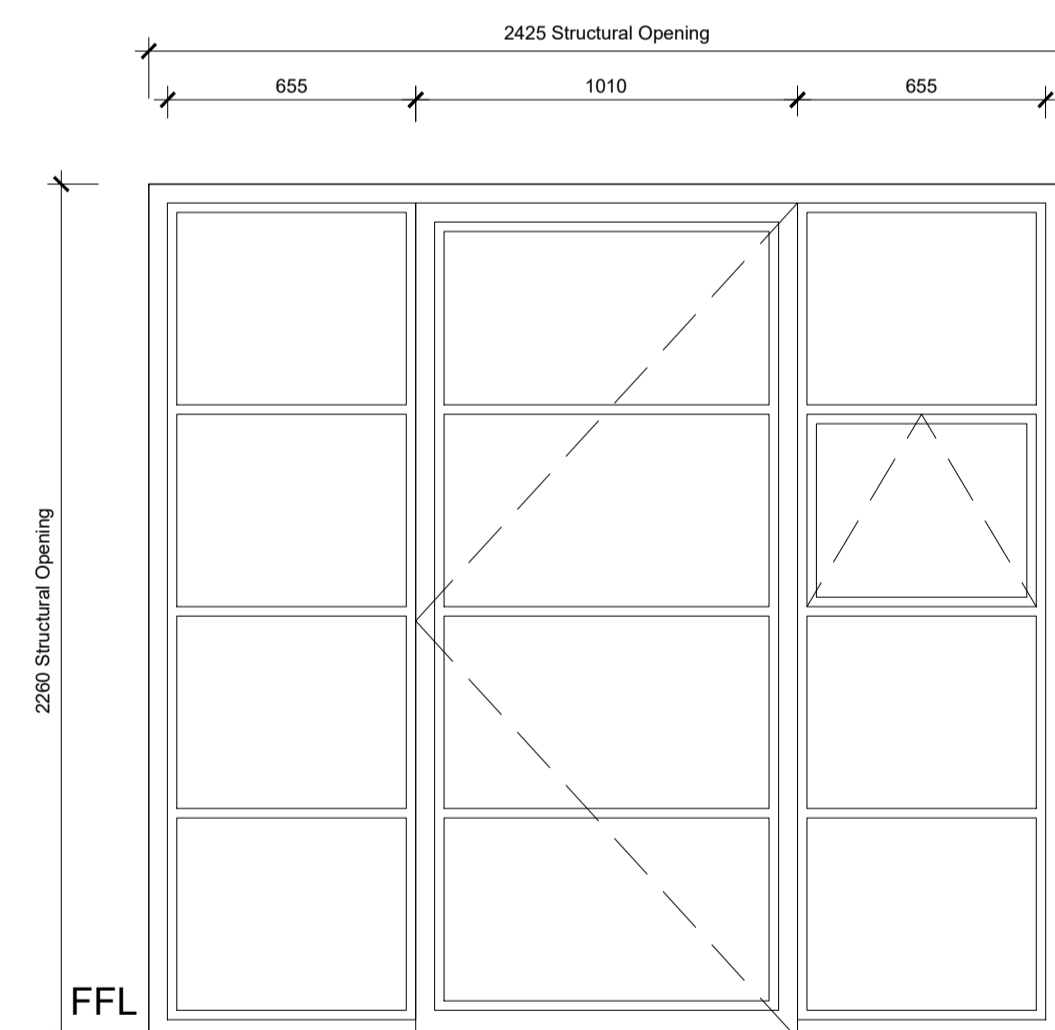

Elevation A

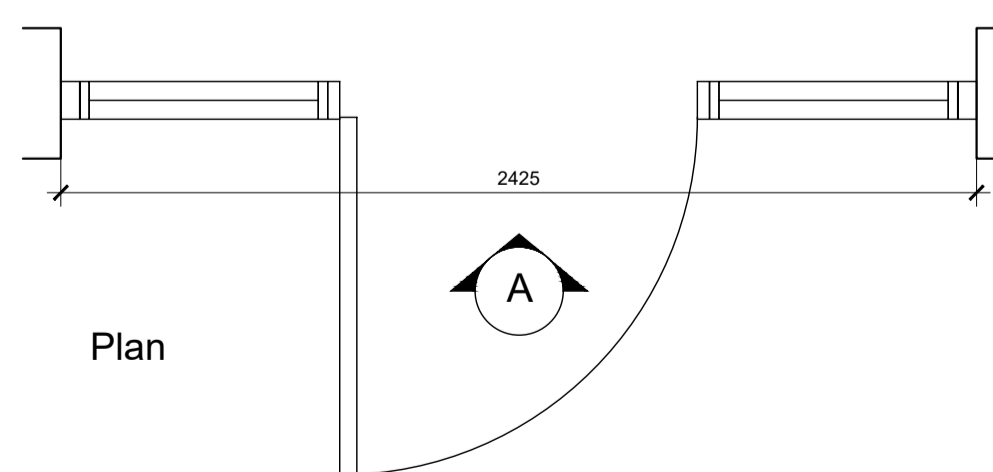

Plan

WINDOW TYPE: W24

WINDOW NUMBERS: W3A.13A

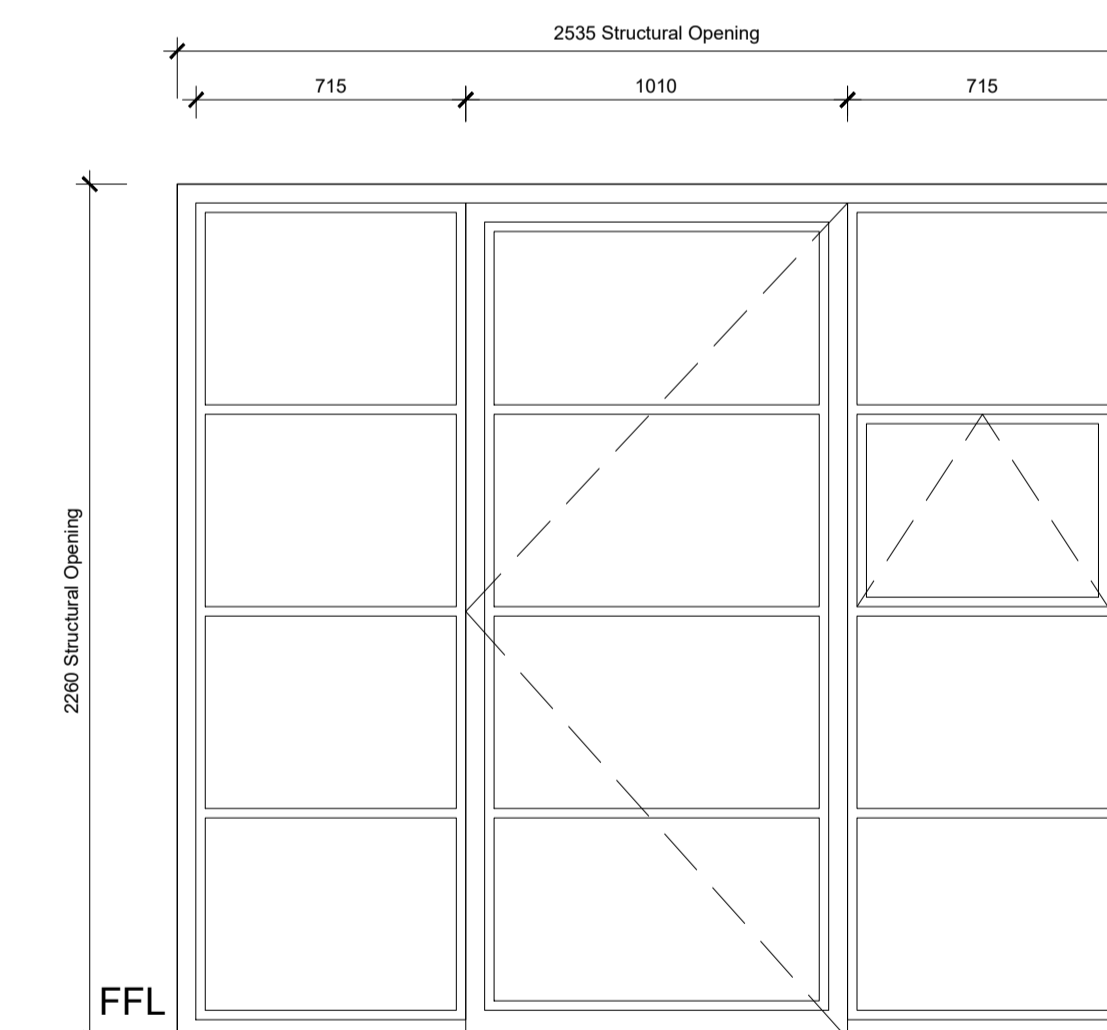

Elevation A

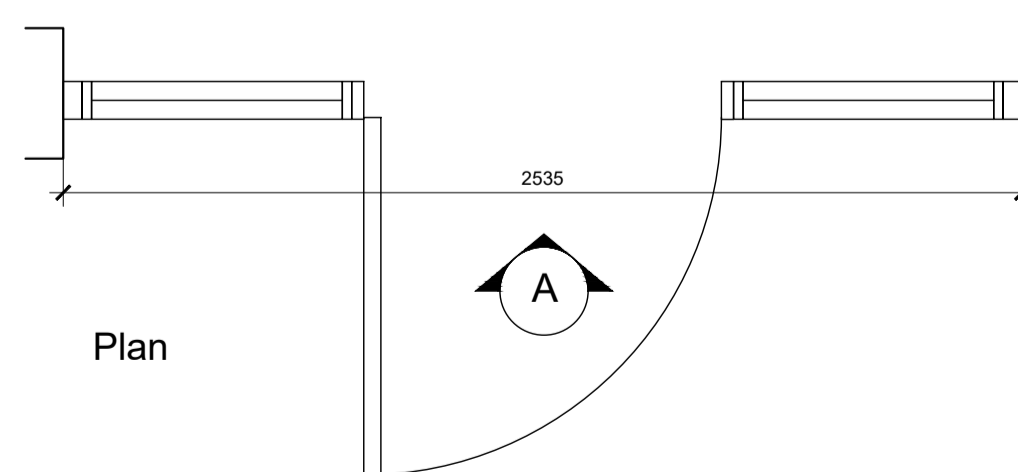

Plan

WINDOW TYPE: W25

WINDOW NUMBERS: W3A.14B

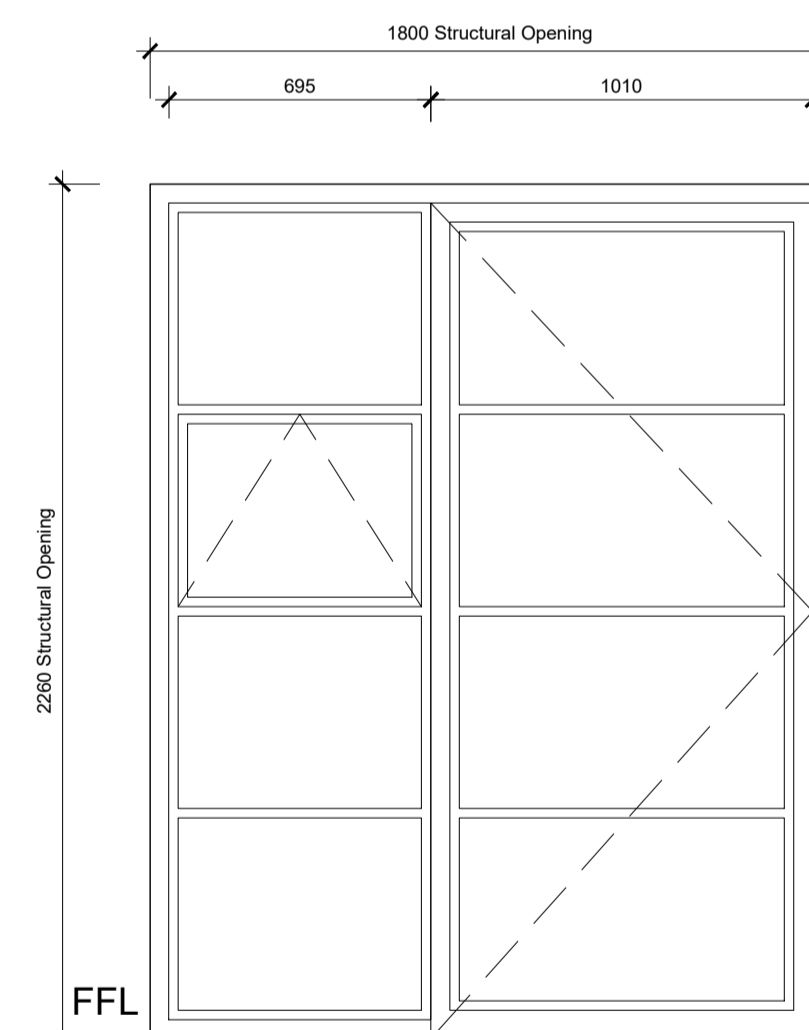

Elevation A

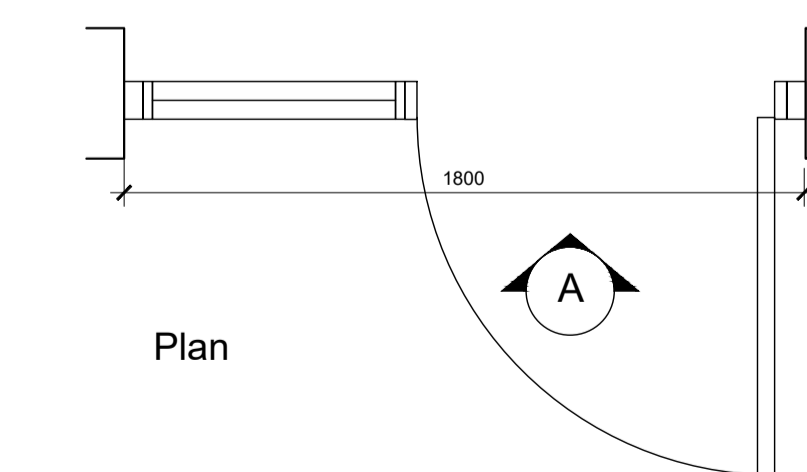

Plan

WINDOW TYPE: W26

WINDOW NUMBERS: W3A.14A

NOTES

DO NOT SCALE - USE FIGURED DIMENSIONS ONLY.  
ALL DIMENSIONS TO BE CHECKED ON SITE PRIOR TO CONSTRUCTION AND ANY DISCREPANCIES TO BE HIGHLIGHTED BY CONTRACTOR.  
THIS DRAWING IS TO BE READ IN CONJUNCTION WITH ALL RELEVANT SPECIFICATIONS AND DRAWINGS.  
ALL LEVELS ARE TO FINISHED LEVELS UNLESS OTHERWISE INDICATED.

LEGEND

NOTES

All windows to achieve a minimum U-Value of 1.4W/m-K  
All windows to have black aluminum frames  
Doors and windows are to be tested and certified to PAS 24  
Trickle vents to be fitted to windows  
Ironmongery to be polished chromium plated finish. hinges shall be stainless steel  
All windows to have restrictors without removable keys  
All windows and doors are to have A or A+ rating in the BRE Green Guide and shall have an appropriate rating by the National Fenestration Registration Council <http://www.nfrc.org/>.  
All windows and doors to have a warranty of not less than 10 years.  
Glazing:  
Laminated glass shall be used for doors and any immediately adjacent glazing in accordance with Part K of the building regulations.  
Laminated glass shall be used for the outer panes of all ground floor windows.  
All doors to have accessible thresholds in accordance with Part M.  
Opening force of main entrance door and doors to commercial units to be in accordance with Part M.

drawing status: **P L A N N I N G**

revision:	description:	date:
PC.01	Issued for information	30.03.20

**CONSTRUCTION**

**SADA**architecture  
P : 26 George Street, St Albans, Hertfordshire, AL3 4ES, UK  
E : [letterbox@sada-architecture.com](mailto:letterbox@sada-architecture.com)  
W : [www.sada-architecture.com](http://www.sada-architecture.com)  
T : 01727 860810

project:	17-010 - HAMSHIRE STREET
drawing:	WINDOW SCHEDULE (Sheet 3 of 4)
date:	21-08-17
drawn by:	DG
check:	CC
scale:	1:20 @ A1
dwg no.:	1222
rev. no.:	C.01

© Copyright: This drawing or design may not be reproduced without permission.

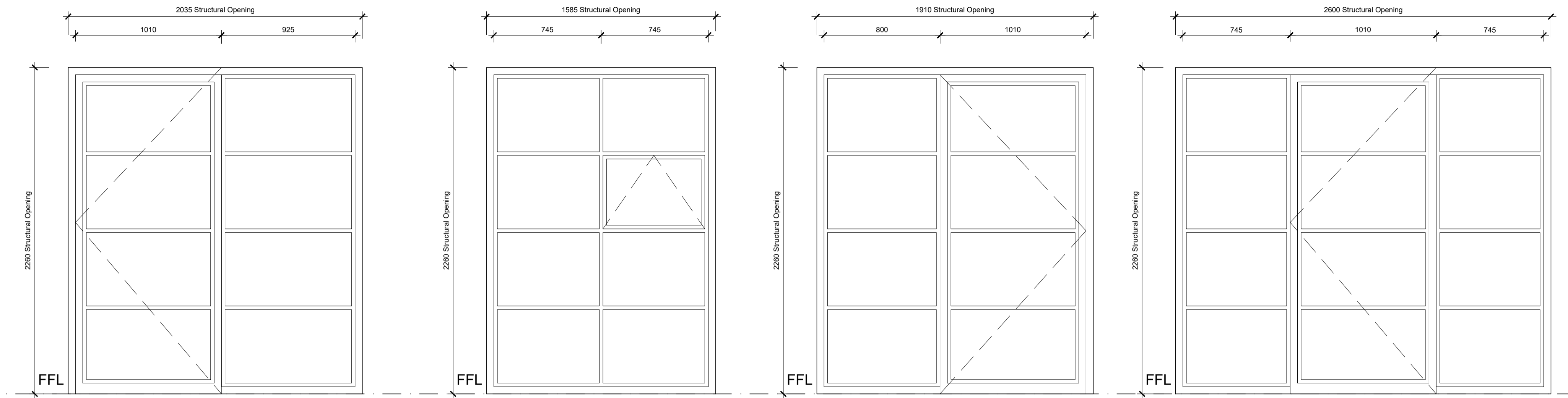

Elevation A

Elevation A

Elevation A

Elevation A

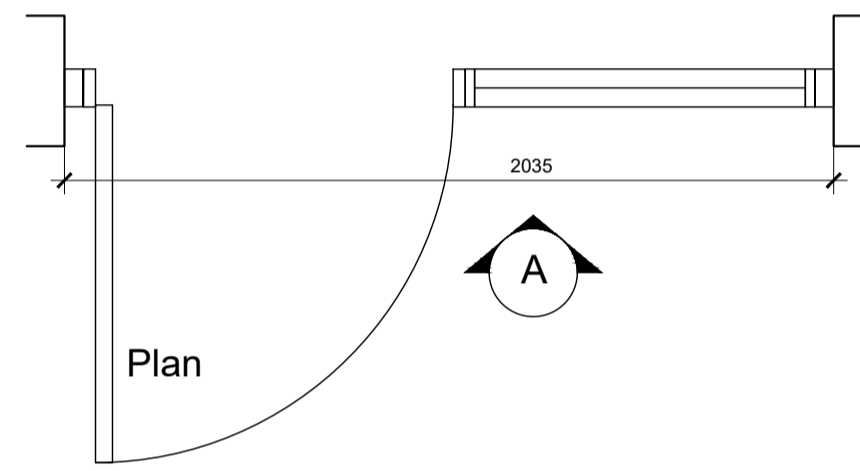

Plan

WINDOW TYPE: W27

WINDOW NUMBERS: W3A.15C

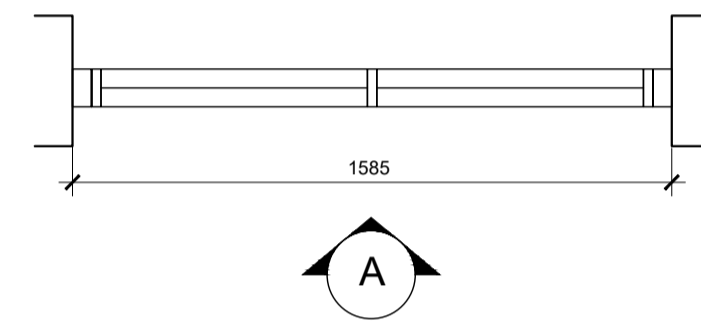

Plan

WINDOW TYPE: W28

WINDOW NUMBERS: W3A.15B

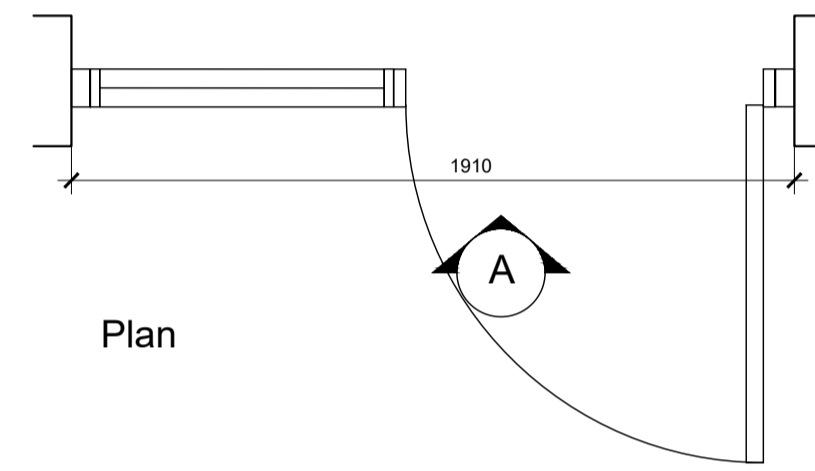

Plan

WINDOW TYPE: W29

WINDOW NUMBERS: W3A.15A

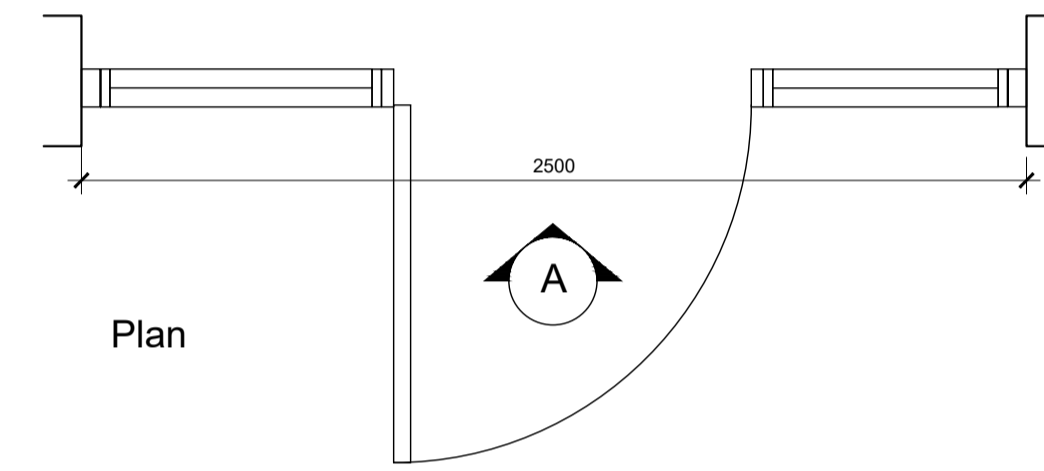

Plan

WINDOW TYPE: W30

WINDOW NUMBERS: W3A.16B

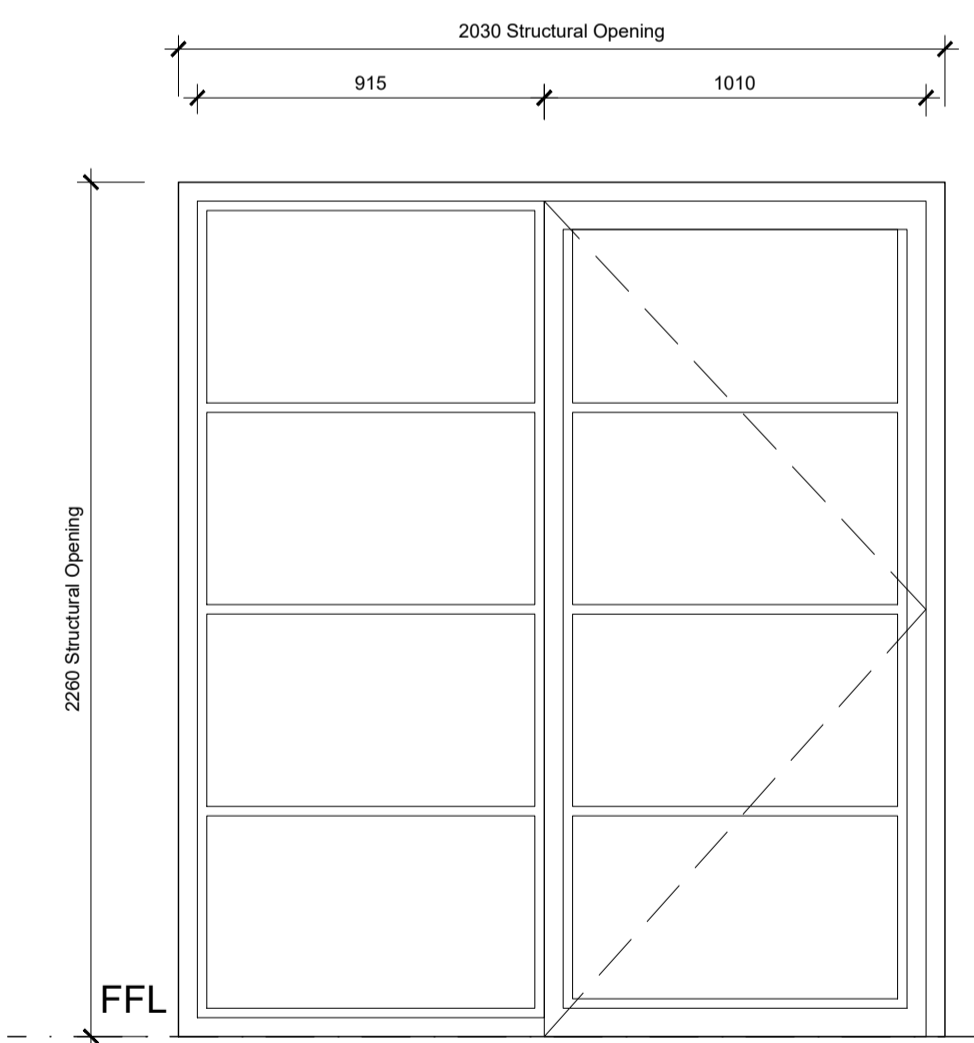

Elevation A

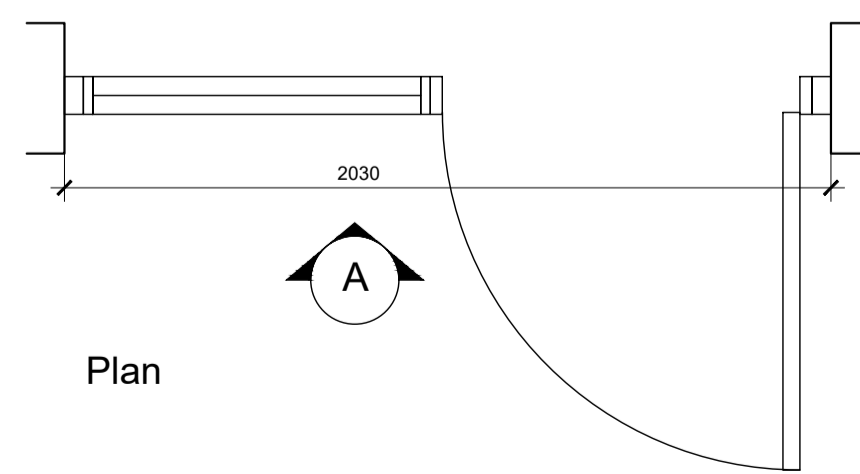

Plan

WINDOW TYPE: W31

WINDOW NUMBERS: W3A.16A

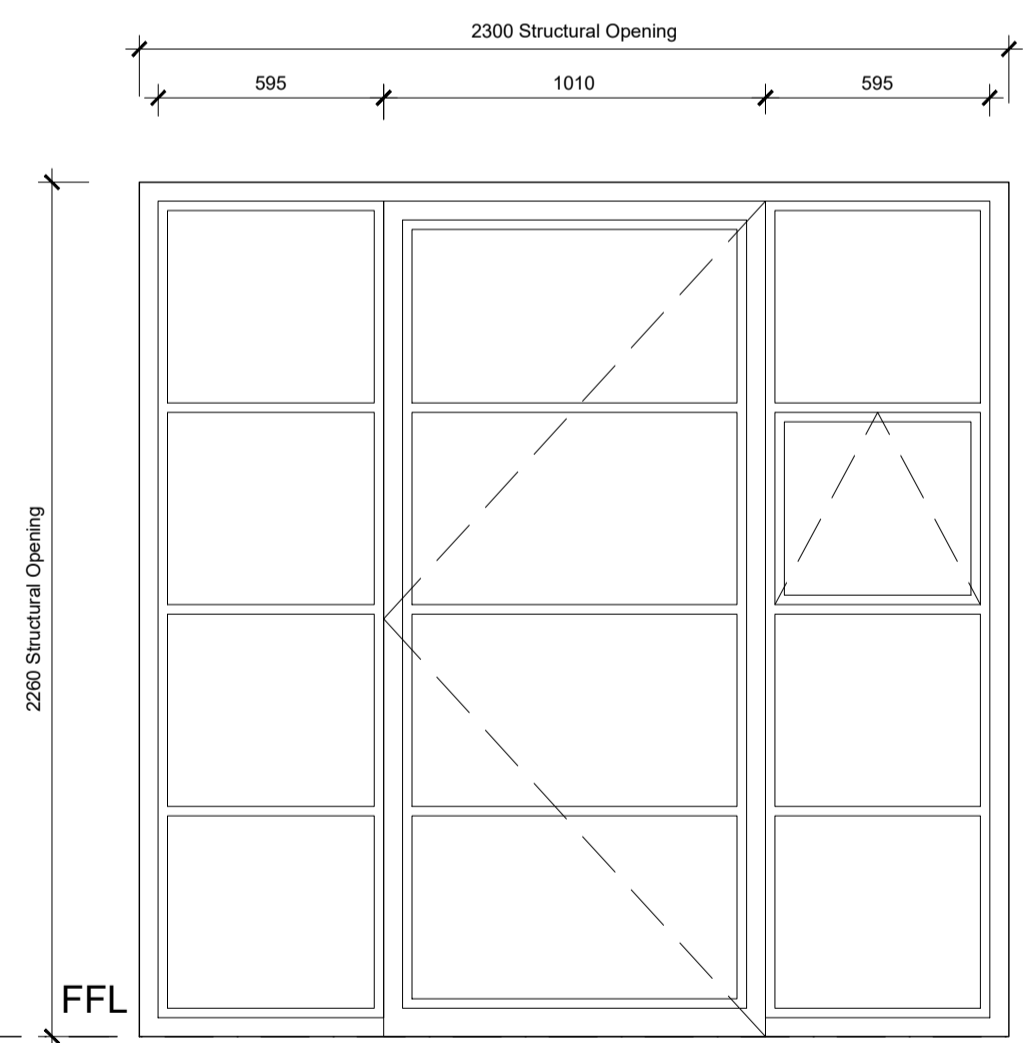

Elevation A

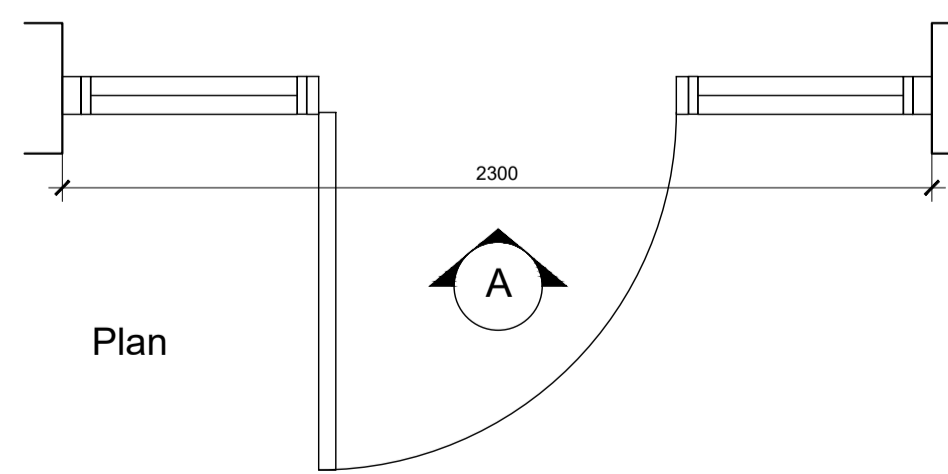

Plan

WINDOW TYPE: W32

WINDOW NUMBERS: W3A.13B

**NOTES**

DO NOT SCALE - USE FIGURED DIMENSIONS ONLY.

ALL DIMENSIONS TO BE CHECKED ON SITE PRIOR TO CONSTRUCTION AND ANY DISCREPANCIES TO BE HIGHLIGHTED BY CONTRACTOR.

THIS DRAWING IS TO BE READ IN CONJUNCTION WITH ALL RELEVANT SPECIFICATIONS AND DRAWINGS.

ALL LEVELS ARE TO FINISHED LEVELS UNLESS OTHERWISE INDICATED.

**LEGEND**

**NOTES**

All windows to achieve a minimum U-Value of 1.4W/m-K

All windows to have black aluminum frames

Doors and windows are to be tested and certified to PAS 24

Trickle vents to be fitted to windows

Ironmongery to be polished chromium plated finish. hinges shall be stainless steel

All windows to have restrictors without removable keys

All windows and doors are to have A or A+ rating in the BRE Green Guide and shall have an appropriate rating by the National Fenestration Registration Council <http://www.nfrc.org/>.

All windows and doors to have a warranty of not less than 10 years.

Glazing:

Laminated glass shall be used for doors and any immediately adjacent glazing in accordance with Part K of the building regulations.

Laminated glass shall be used for the outer panes of all ground floor windows.

All doors to have accessible thresholds in accordance with Part M.

Opening force of main entrance door and doors to commercial units to be in accordance with Part M.

drawing status: **P L A N N I N G**

revision:	description:	date:
PC.01	Issued for Information	30.03.20

**SADAarchitecture**

P : 26 George Street, St Albans, Hertfordshire, AL3 4ES, UK  
 E : [letterbox@sada-architecture.com](mailto:letterbox@sada-architecture.com)  
 W : [www.sada-architecture.com](http://www.sada-architecture.com)  
 T : 01727 860810

project: 17-010 - HAMSHIRE STREET  
 drawing: WINDOW SCHEDULE (Sheet 4 of 4)  
 date: 21-08-17 drawn by: DG check: CC  
 scale: 1:20 @ A1 drwg no.: 1222 rev. no.: C.01  
 © Copyright. This drawing or design may not be reproduced without permission.