

Internal Room Elevation  
Scale: 1:10

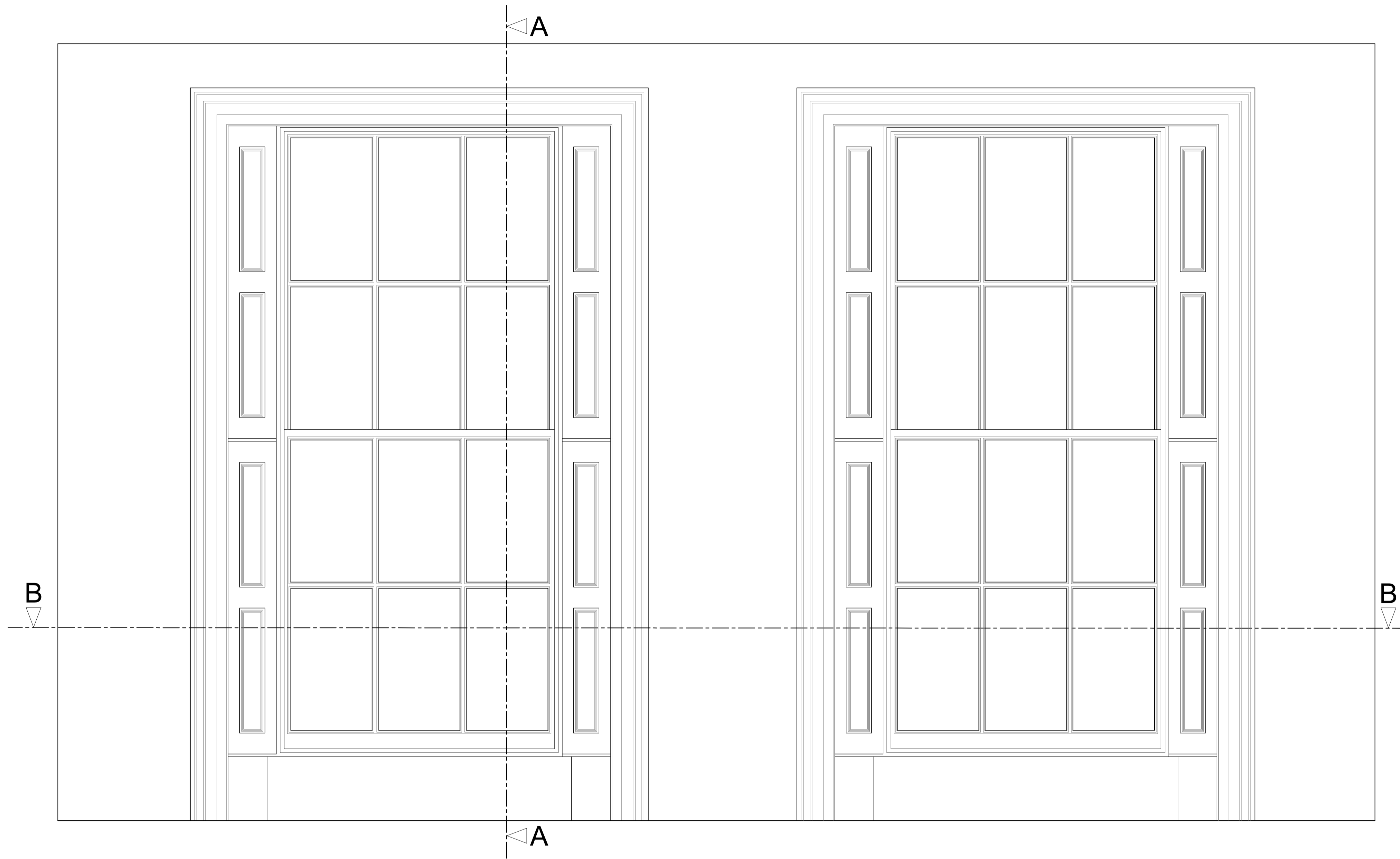

Section A-A through External Wall  
Scale: 1:10

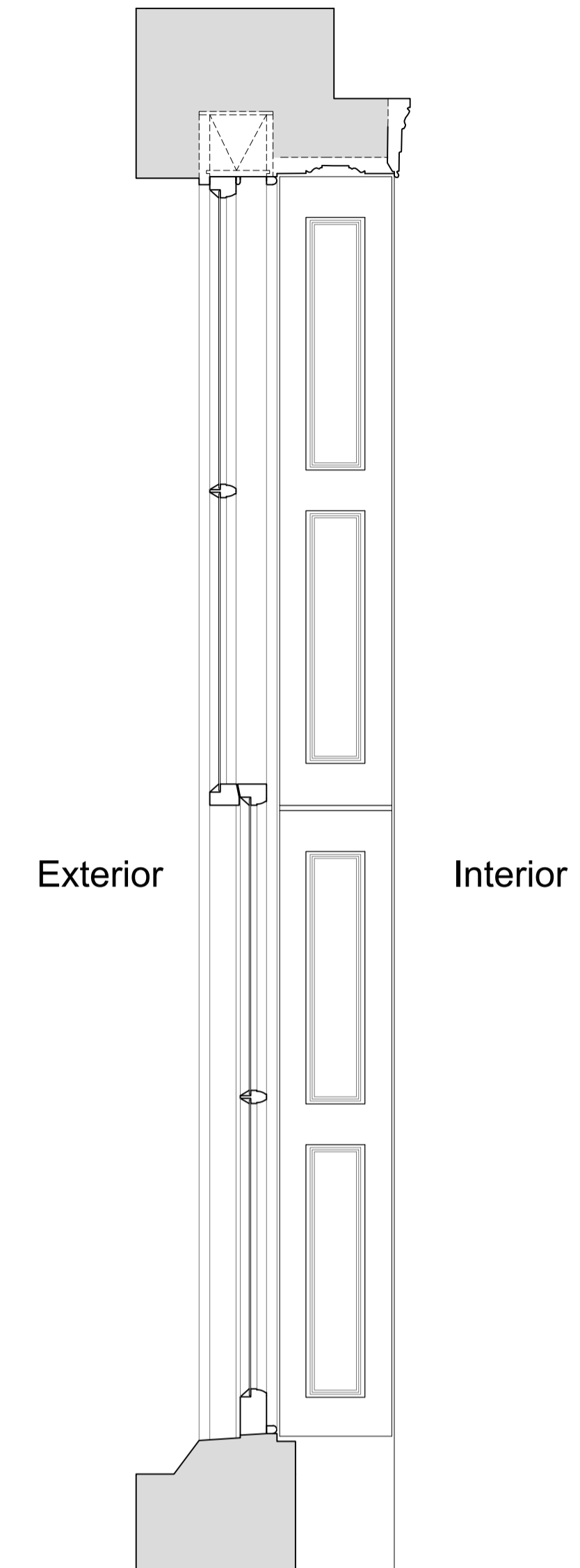

Plan Section B-B  
Scale: 1:10

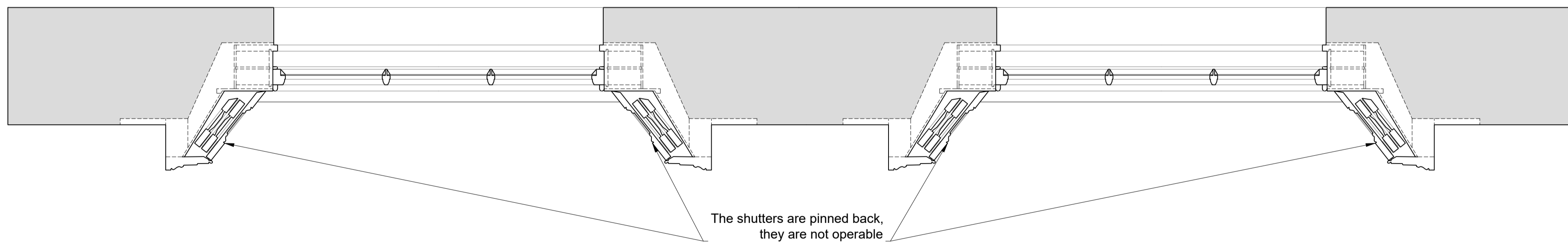

Revision	Date	Assessment
1.0	14-06-2019	Issued for listed building consent application
2.0	24-03-2021	Issued for listed building consent application

Do not reproduce this drawing without written permission  
All dimensions are in millimetres unless stated otherwise

**HS2**

High Speed (HS2) Limited  
1st-3rd Floor  
The Podium  
1 Eversholt Street  
London NW1 2DN

**COSTAIN SKANSKA**

Costain Skanska Joint Venture  
9th Floor  
The Tower  
1 Eversholt Street  
London NW1 2DN

Site Address:  
32 C Mornington Terrace, London NW1

Drawing Title:  
First Floor - Lounge: EXISTING Window Joinery Details -  
Sheet 1 of 3

Drawn by: AP & PB  
Checked by: AP  
Presentation Scale: as shown @ A1

Date: 13-06-2019  
Drawing No: WPI P066 NI - 32C MT-EX-FF-J-03  
Revision: 2.0

Drawing Not For Construction

Internal Room Elevation with Secondary Glazing Installed  
Scale: 1:10

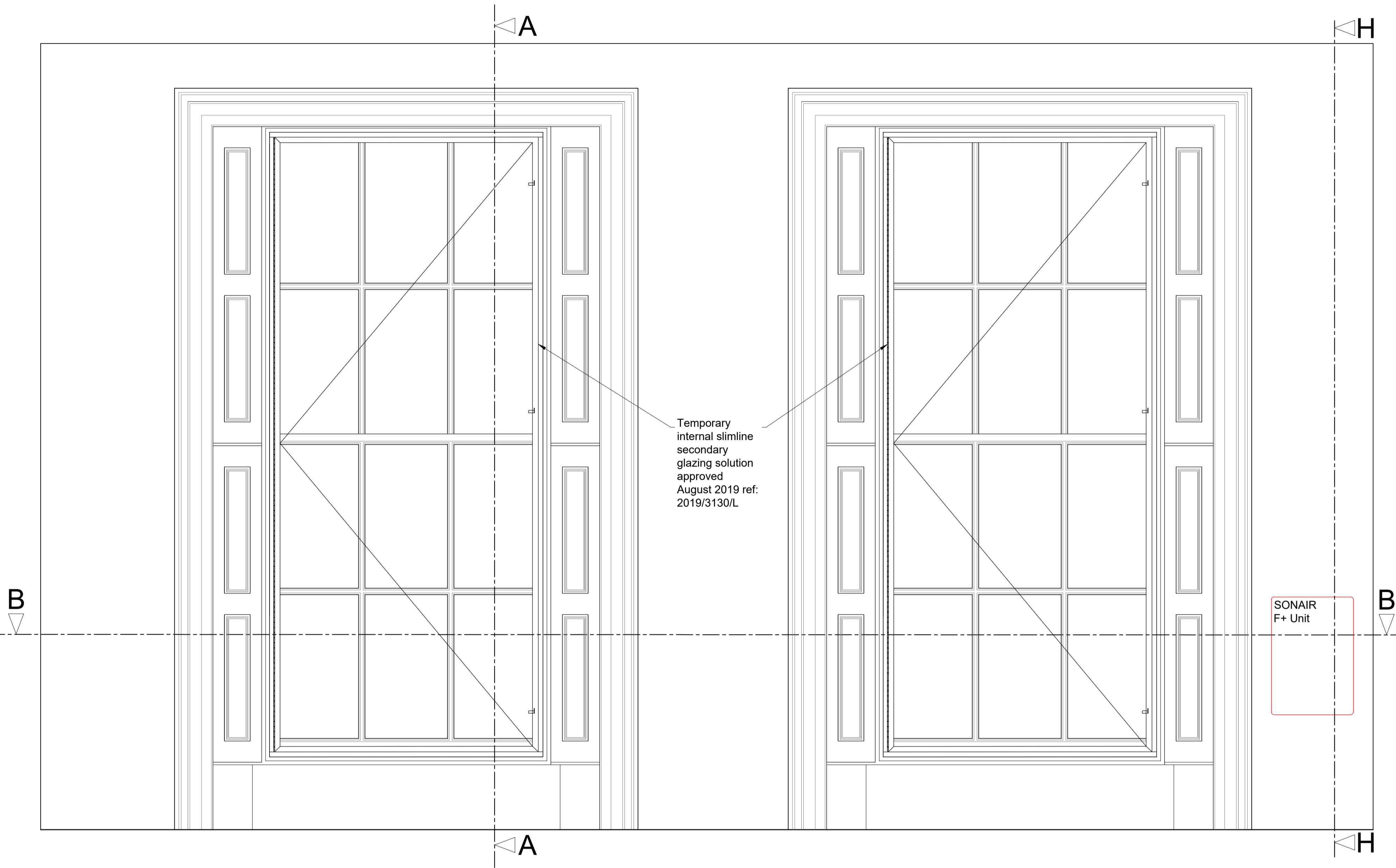

Section A-A through External Wall with Secondary Glazing Installed  
Scale: 1:10

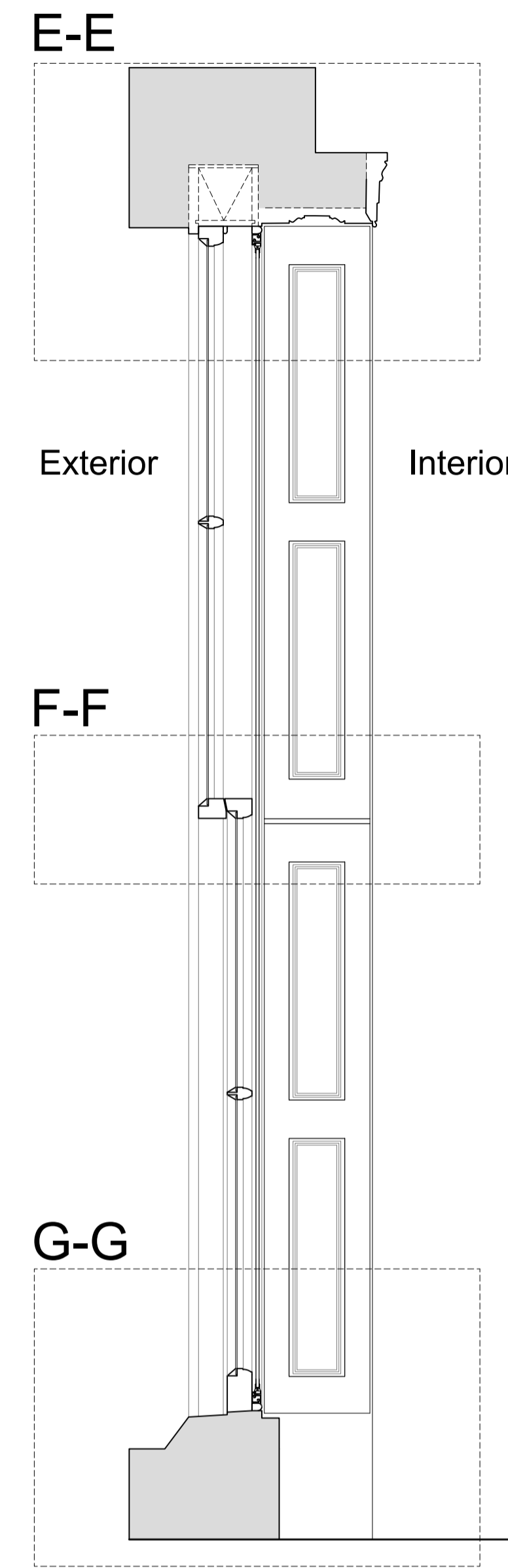

Section H-H through External Wall with Mechanical Ventilation Installed  
Scale: 1:10

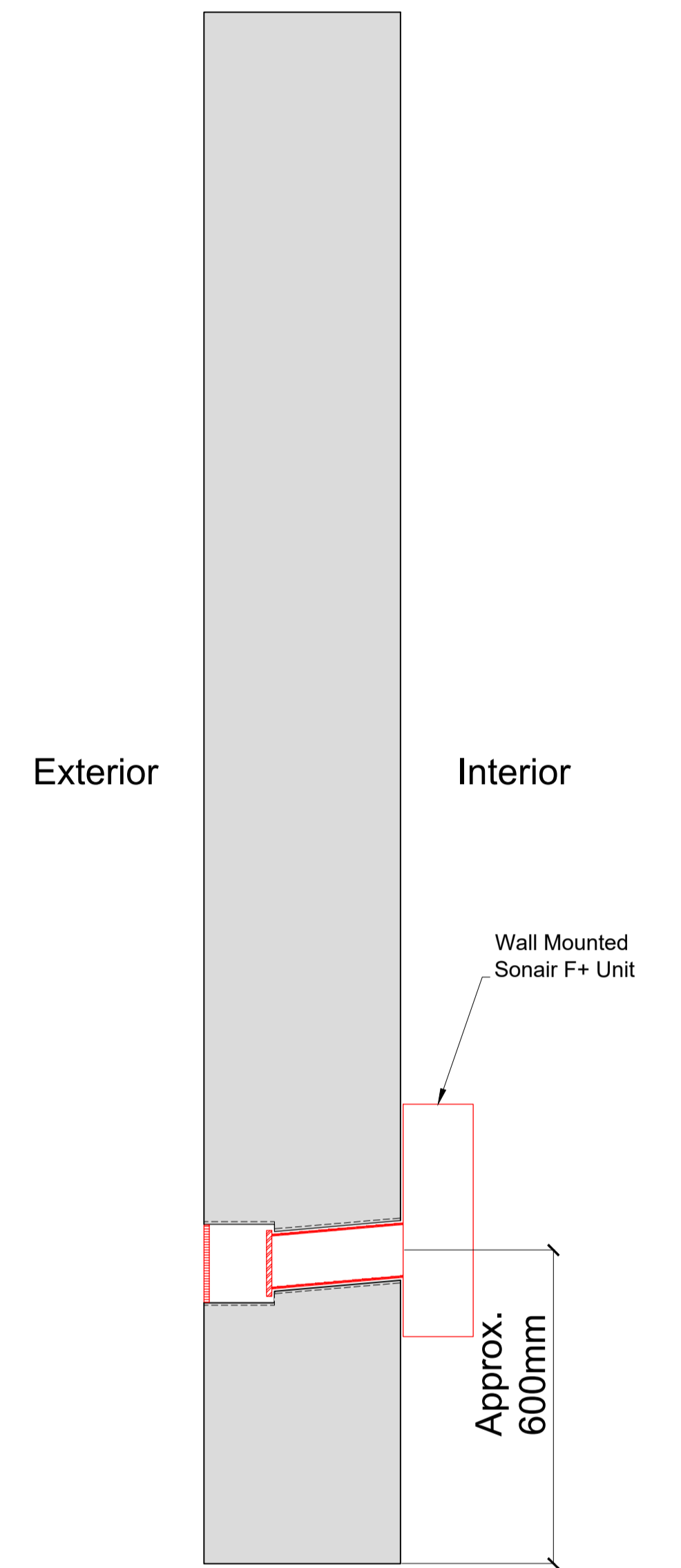

Plan Section B-B with Secondary Glazing Installed  
Scale: 1:10

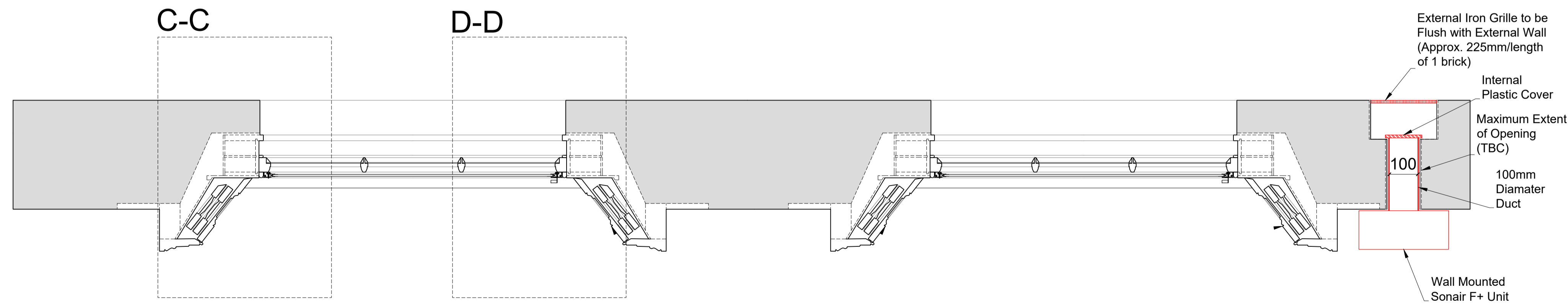

PROPOSALS SHOWN IN RED FOR VISUAL CLARITY

Detail of Sonair Unit  
Scale: 1:5

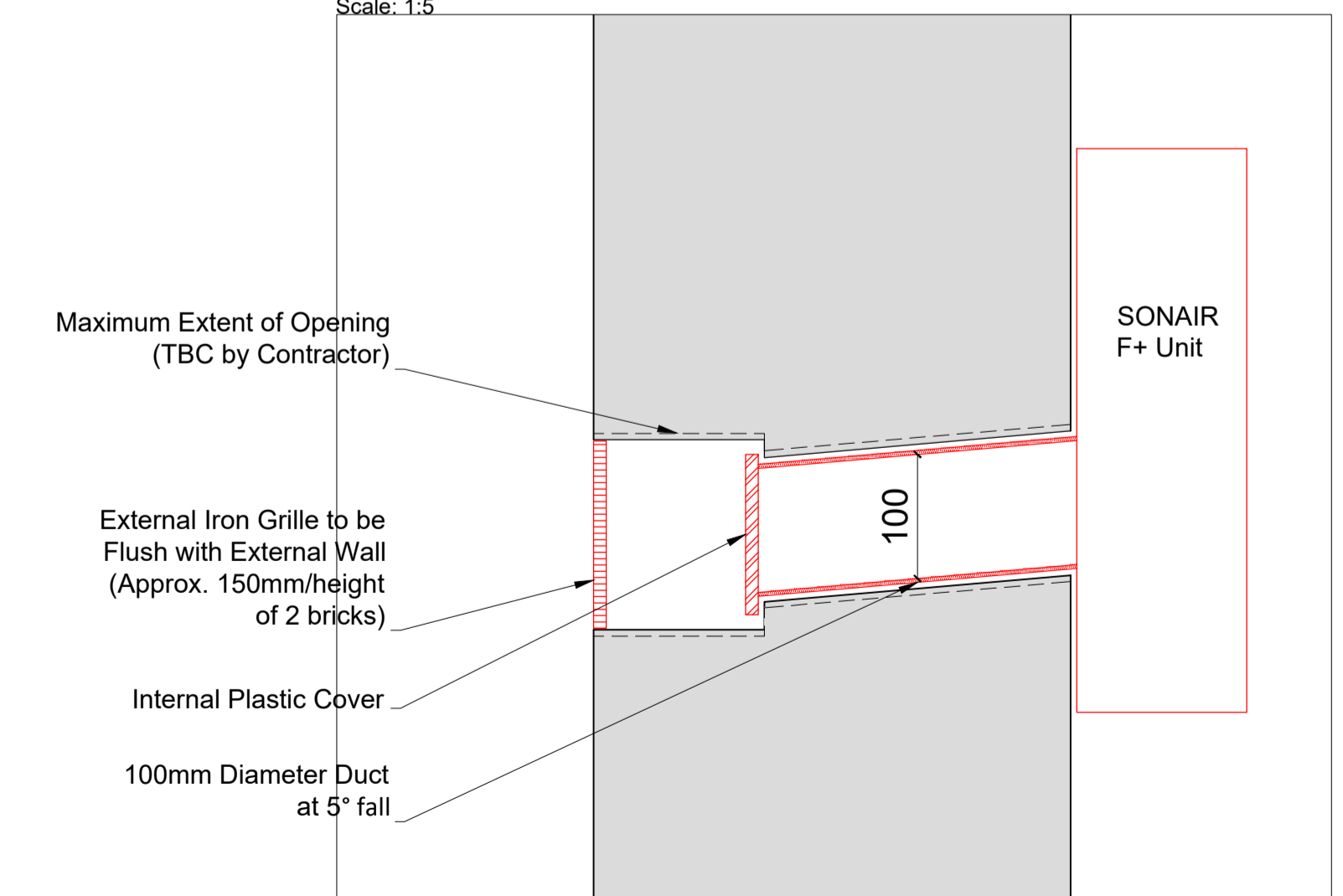

Revision	Date	Assessment
1.0	14-06-2019	Issued for listed building consent application
2.0	24-03-2021	Issued for listed building consent application

Do not reproduce this drawing without written permission  
All dimensions are in millimetres unless stated otherwise

**HS2**

High Speed (HS2) Limited  
1st-3rd Floor  
The Tower  
1 Eversholt Street  
London NW1 2DN

**COSTAIN SKANSKA**

Costain Skanska Joint Venture  
9th Floor  
The Tower  
1 Eversholt Street  
London NW1 2DN

Site Address:  
32 C Mornington Terrace, London NW1

Drawing Title:  
First Floor - Lounge: PROPOSED SONAIR Details -Sheet 2 of 3

Drawn by: AP & PB      Drawn by: AP      Checked by: OB      Presentation Scale: as shown @ A1

Date: 13-06-2019      Drawing No: WPI P066 NI - 32C MT-PR-FF-J-03.1      Revision: 2.0

Drawing Not For Construction