

EXTERNAL FURNITURE REFERENCES

Refer to Lagkagehuset furniture and accessory manual for further details

LAYOUT DRAWN SUBJECT TO THE FOLLOWING:
- AGREEMENT WITH LOCAL AUTHORITY

COVERS	QTY
EXTERNAL	12

ET1 **QTY 06**
Steel coated Table

DIMENSIONS:
W X D X H
70 X 60 X 74 cm

EC1 **QTY 12**
Steel coated Chair

DIMENSIONS:
W X D X H
52 X 57 X 88 cm

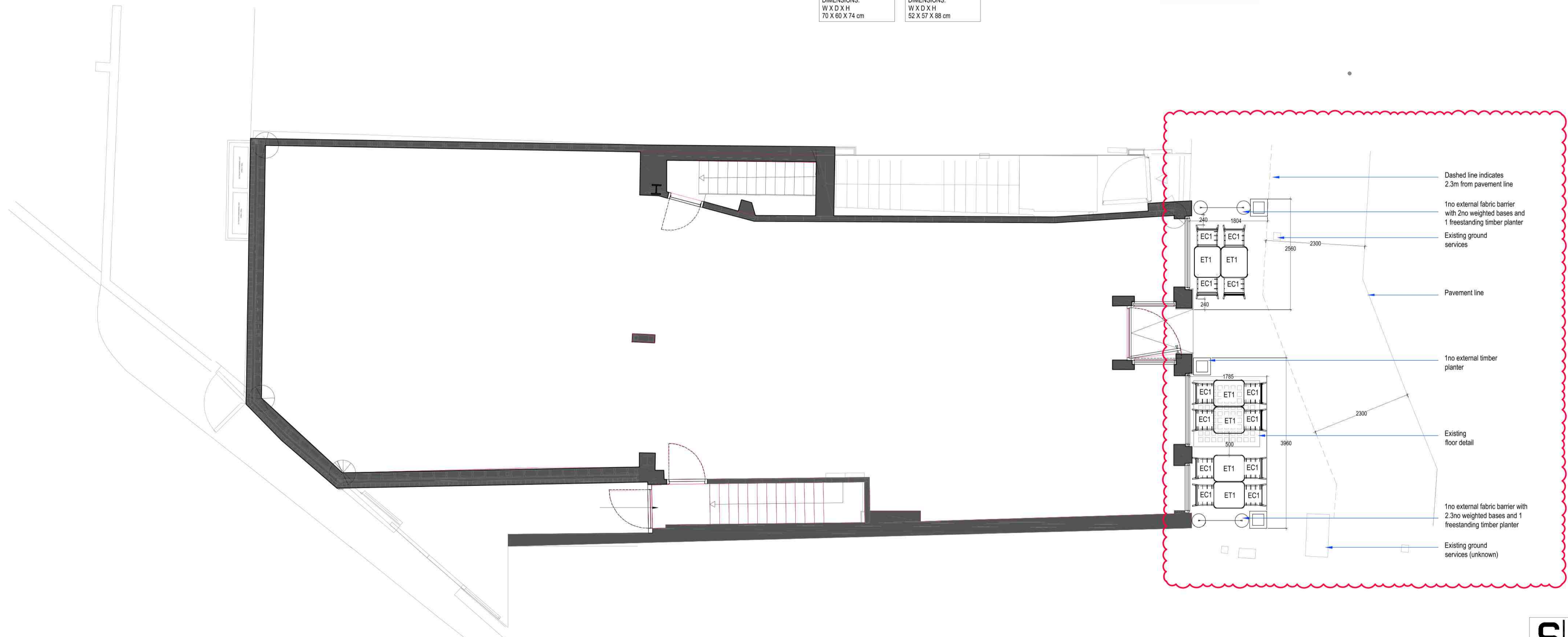
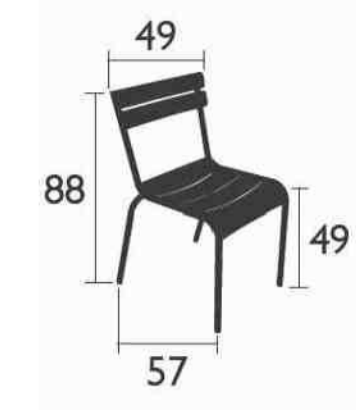

- Dashed line indicates 2.3m from pavement line
- 1no external fabric barrier with 2no weighted bases and 1 freestanding timber planter
- Existing ground services
- Pavement line
- 1no external timber planter
- Existing floor detail
- 1no external fabric barrier with 2.3no weighted bases and 1 freestanding timber planter
- Existing ground services (unknown)

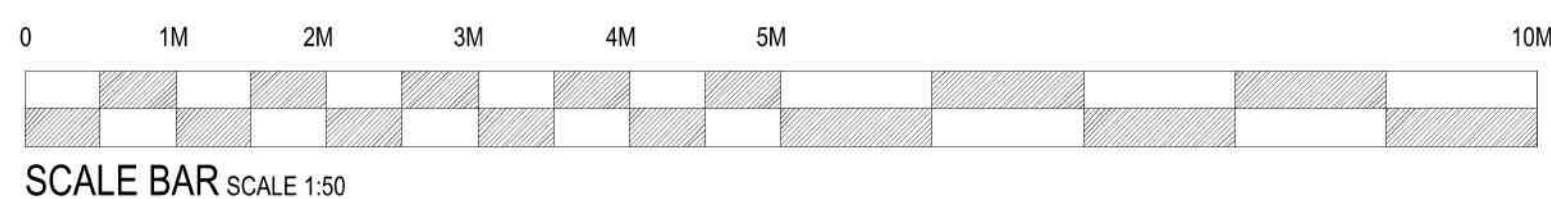

SEA DESIGN GROUP

Client
OLE & STEEN

Project
**38-40 HIGH STREET
HAMPSTEAD**

Drawing Title
PROPOSED EXTERNAL SEATING LAYOUT

Scale: 1:50/20@A1 Date: 26/10/20

Drg No: 219142/ESL Rev: E

Drg By: SJ Check: MS

Revisions	By	Date
A.	Layout updated to suit feedback - CW	24/11/20
B.	Information updated to suit feedback - VS	04/12/20
C.	Dimensions clarified - SJ	04/12/20
D.	Layout amended to allow for 2.3m clearance - SJ	03/02/21
E.	Furniture layout amended to allow for 2.3m clearance - AM	04/03/21