

PLAN VIEW ON ROLLER SHUTTER

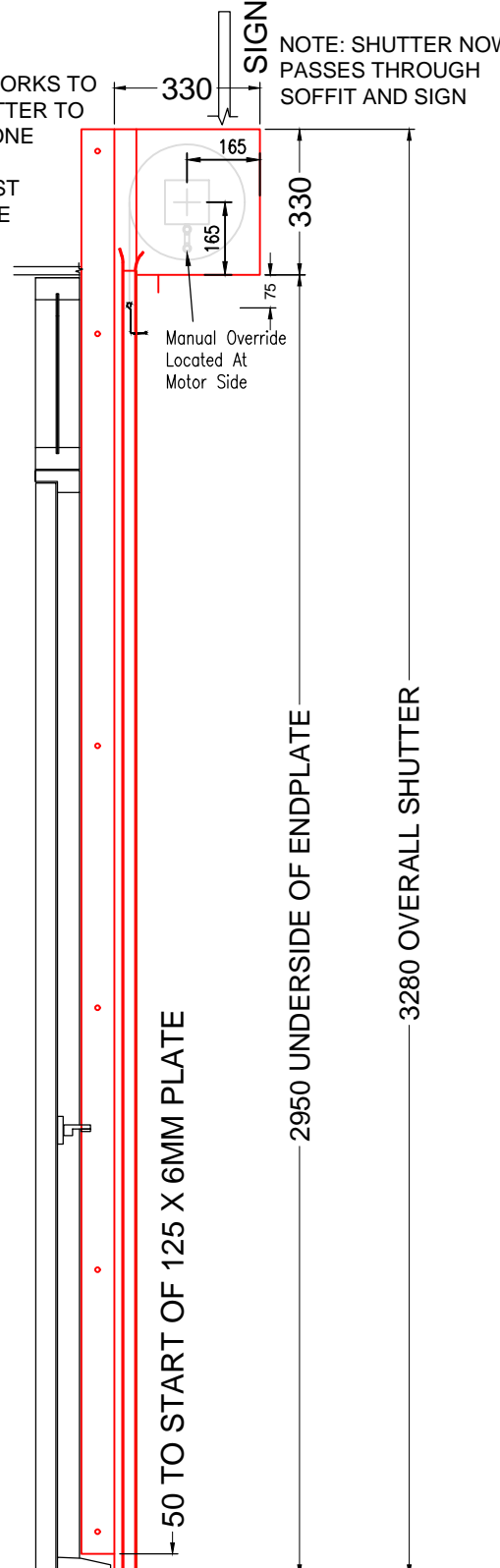
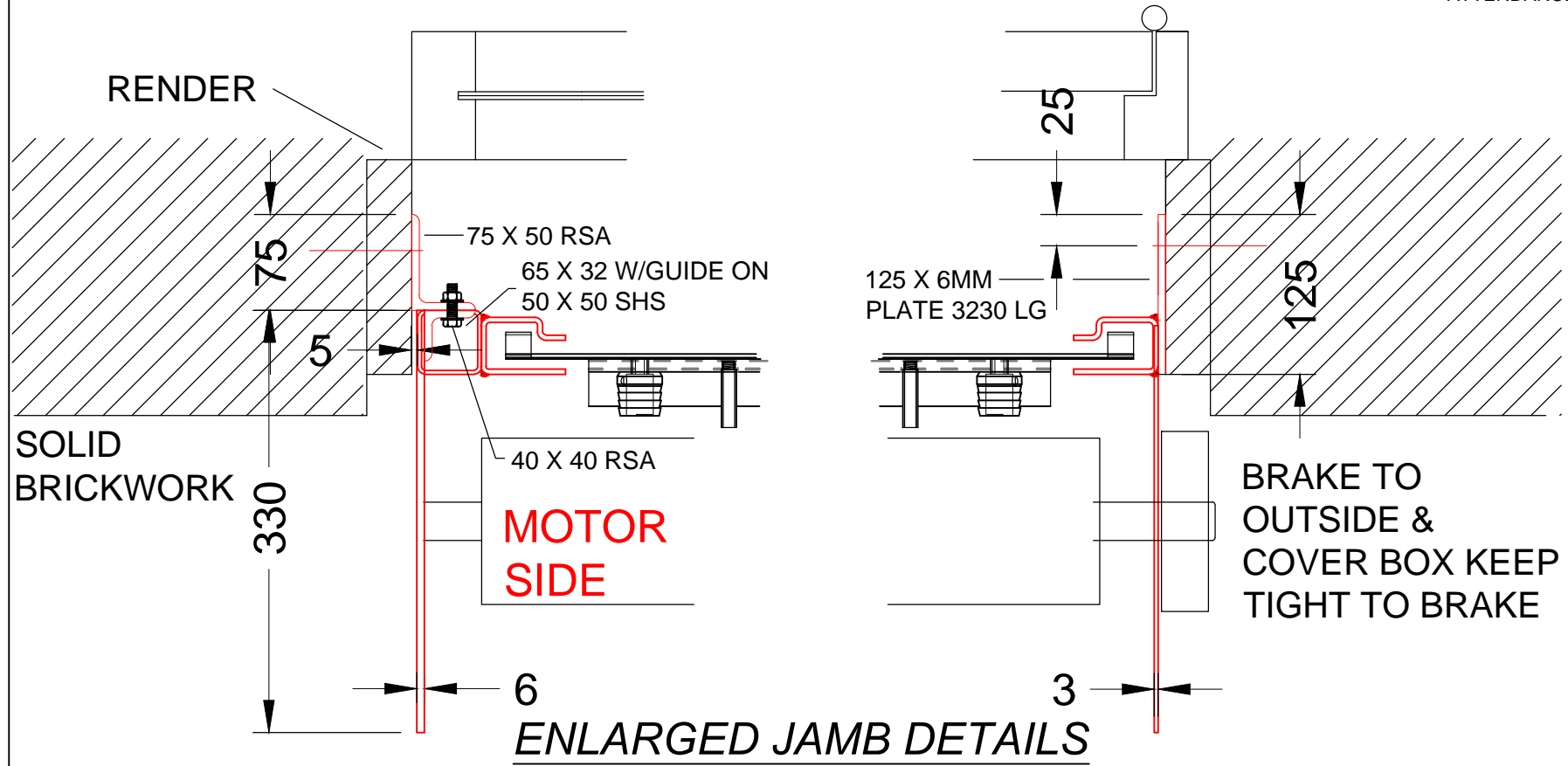

CHECK YOUR SHUTTER SPECIFICATION 1ST

1No 240v13amp switched fused spur is required for Non Fire Rated Single Phase motors.

Single Phase Fire Shutters require a N/O clean set of contacts to activate the fire panel plus 2No 240v 13amp spurs, 1 for the motor & 1 for the fire panel. The fused spurs is to be provided within 1M of the shutters at motor height.

For each 3 Phase Shutter we require 1No 16amp Spin 415v wall socket to be located at high level no more than 1m from the shutter motor. Three Phase shutters = 415v 16amp.

The fused spurs is to be provided within 1M of the shutters at motor height.

This is to be completed prior to Armourpost's attendance.

<VERY IMPORTANT>

All internal/external panels in way of shutters **MUST** be easily removable to permit access to full length of shutter barrel for adjustment, maintenance and repair.

All manual over-ride positions **MUST** be agreed by Architect **BEFORE** shutter installation.

Specification:

SR2 - Single Phase Electronically Operated Defender Rolling Shutter Constructed from 76mm Curved Solid Interlocking Lath Sections. Operated Via Remote (4No) Lock Controller Manual Override Facility. Safety Brake Polyester Powder Coated - Ral BS - 9010 White

TO BE FILLED IN AT THE POINT OF FABRICATION ONLY

REF:	B.O.G	BTW-E-PLT	US/EPLT	O/A HGT	CHK
RS01:	3835	3875	2950	3280	

DOUBLE CHECK WITH ALL SIZES SHOWN ON DWG ABOVE

REV B 25.01.21	INCREASED IN HEIGHT BY ARCHITECT - 340MM
REV A 21.01.21	PPC WHITE NOT BLACK
21.01.21	FIRST ISSUE
REVISION	
DIMENSIONS OBTAINED FROM: AP SURVEY <input type="checkbox"/> AGREED <input type="checkbox"/> CLIENT <input type="checkbox"/> DESIGN <input type="checkbox"/>	

ARMOURPOST LIMITED

Saltmeadows Road, East Gateshead Industrial Estate
Gateshead, Tyne & Wear. NE8 3AH

Tel: 0191 478 7878 Fax: 0191 478 2588

SITE:
Morrison's Chalk Farm
Basebuild

SHUTTER/DOOR REF:
SR2 Security Shutter

LOCATION:
New Pharmacy

BY: N.G.L.	DWG No: 35822 01	REV No: B
CHK BY:		

