

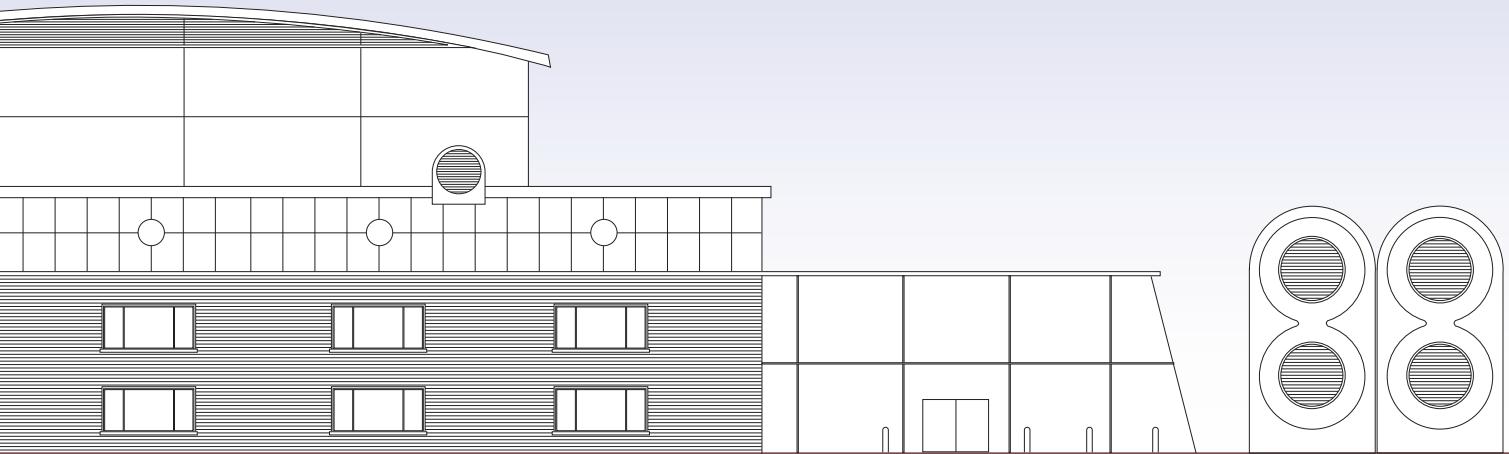

GILBERTS

CI/SFB	
(57.7)	Xh
LOUVRES 2	
March 2016	



INTEGRATED LOUVRE SYSTEMS

STANDARD LOUVRES

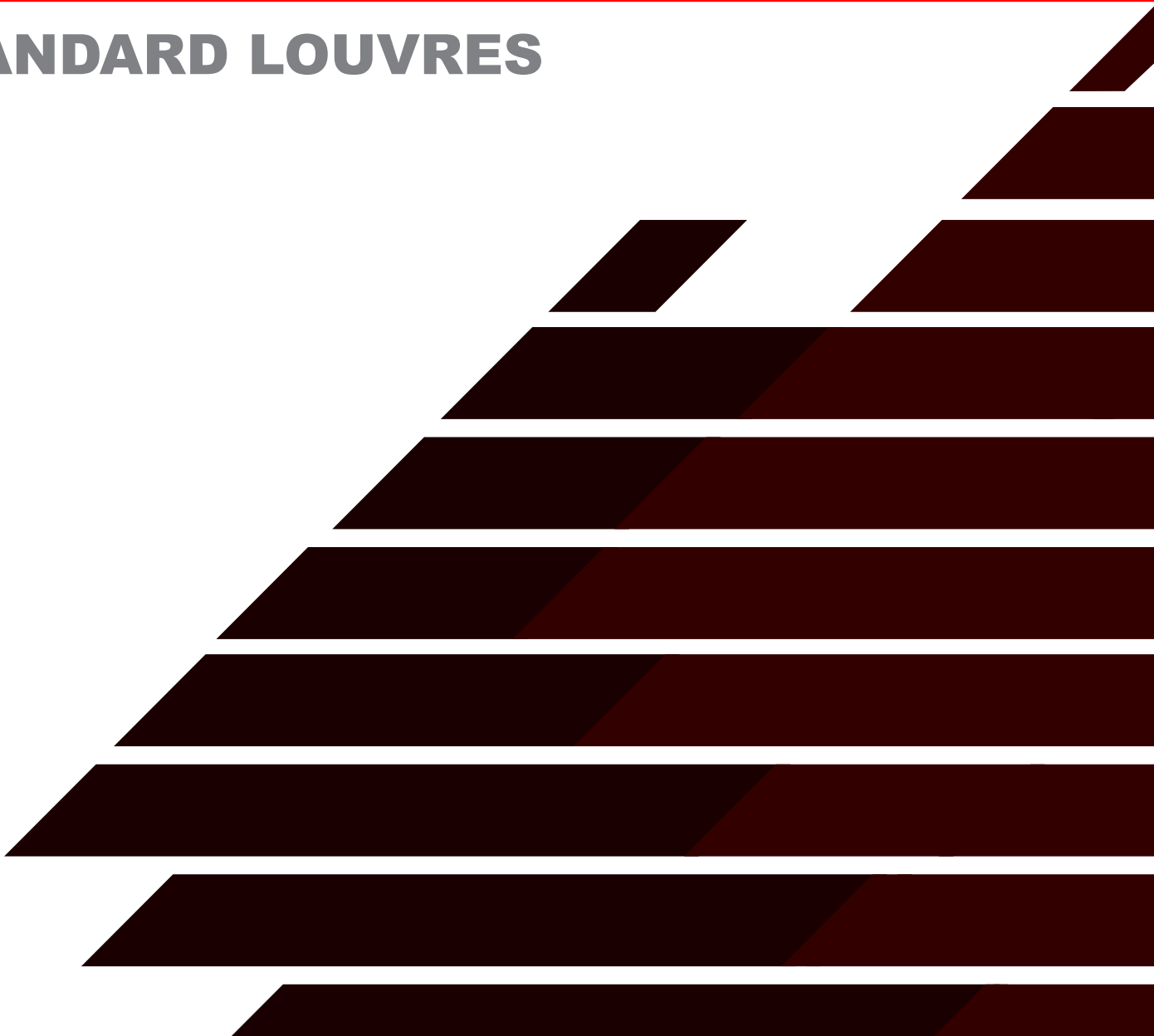



38mm PITCH LOUVRES

38mm PITCH LOUVRES

Series WG38 with its 38mm Pitch fixed Blades represents the smallest Louvre profile available in this system. This unit was designed to provide a neat and compact appearance for smaller Louvre applications combined with a convenient low size to weight ratio for easy handling. The profile of the Louvre ensures it offers good resistance to the ingress of rain even with its high 50% free area. Both flanged and recessed channel frame options can be selected along with standard bird guard, insect screen and weather cill accessories.

SERIES OPTIONS

WGF/38: Comprises of 16 SWG Louvres on 38mm centres in a 32mm wide Flanged Frame.

WGC/38: Comprises of 16 SWG Louvres on 38mm centres in a 38mm deep Channel Frame.

SIZE RANGE

Available sizes range from 100mm square up to 1750mm square in one unit. Above this size Louvres are supplied as multiple units with a continuous appearance for assembly on site.

(NB: On multiple assemblies the Frame/Flange size increases to 50mm angle).

FIXING

WGF/38: Flange screw fixing using the pre-drilled 4mm countersunk holes. Flanges can be supplied un-drilled upon request.

WGC/38: Rear fixing cleats mounted off the housing frame to facilitate screw fixing into adjacent timber, masonry or duct.

FINISH

The standard Louvre finish is mill finish (ie: un-treated). Polyester Powder Coatings, PVF and Anodised Finishes are also available on request.

LENGTH OF BLADE	VERTICAL MULLION WHEN REQUIRED
Up to 750	None
Over 750 - 1500	One
Over 1500	One every 750 pitch

NB: If Louvre is powder coated, Mullion pitch must be 500mm

FLANGE FACE FIXING DETAILS	
W-H Dim.	A Dim.
Up to 500	75.0
500 to 1750	150.0
1800 & over 150 & centre fixing holes	

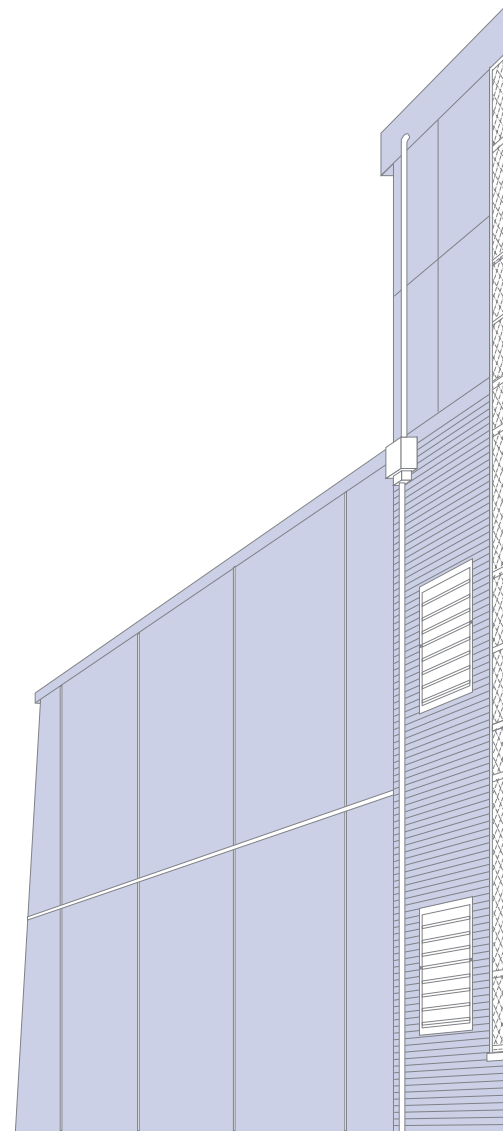

WG-38 SERIES

WGF -38

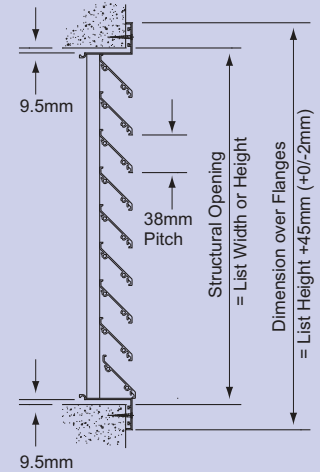
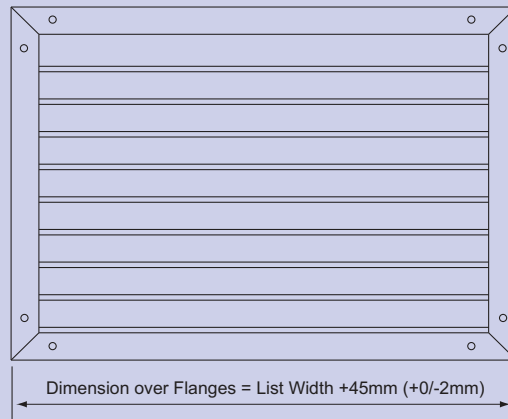

WGC -38

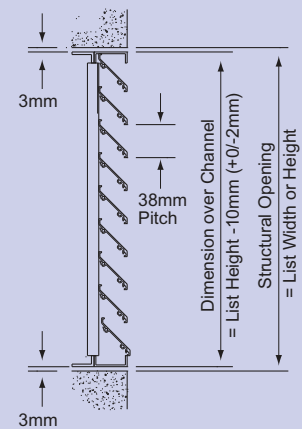
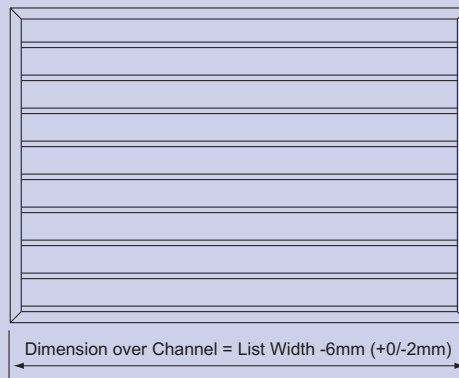

WGF -38

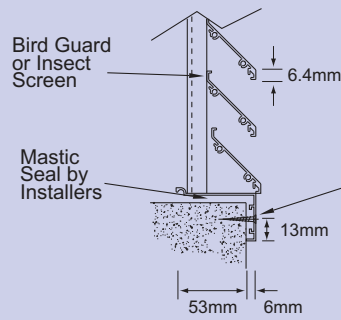

WGC -38

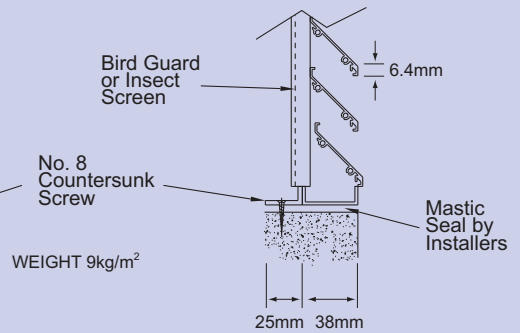

SERIES:	Flanged - WGF Channel Frame - WGC	WGC
BLADE PITCH:	38mm	38
SIZE:	(mm Width x Height)	1200 x 800
OPTIONS:	Birdguard - BG Insect Screen - IS	BG
EXTRA OPTIONS:	Weather Cill - WC	WC
SPECIAL FIXING OPTIONS:	Rear Lug Fixing - RLF	RLF
BLANKING PLATE OPTIONS:	Standard - SBP Insulated - IBP	SBP
FINISH:	(Please Specify)	Mill Finish (Standard Finish)
NUMBER REQUIRED:		15

WG-75 SERIES

WGF-75

4mm Countersunk Fixing Holes for No 8 Screws

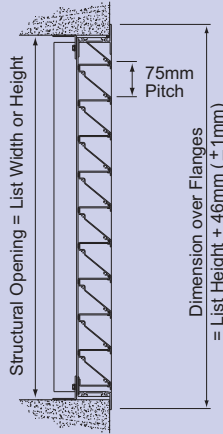
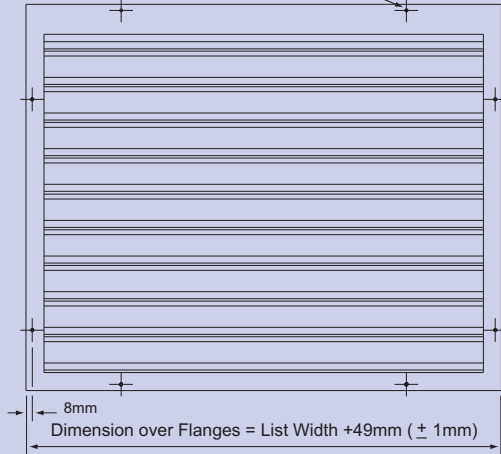

WGC-75

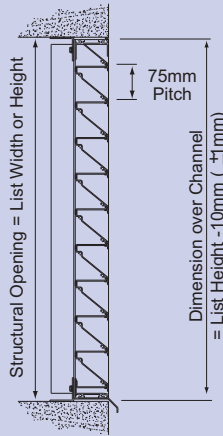
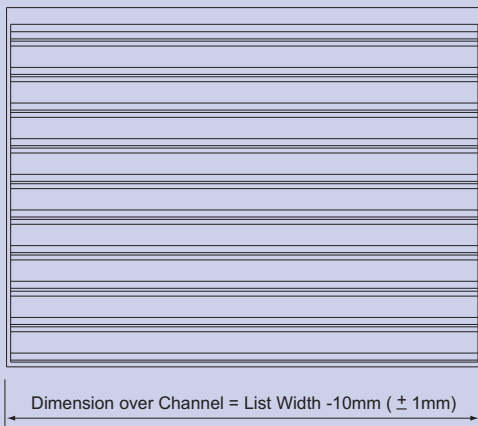

WGF-75

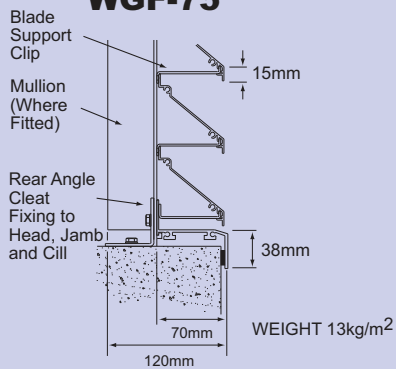

WGC-75

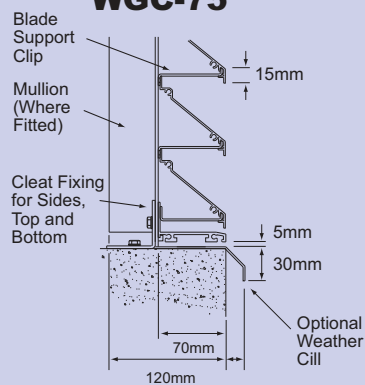

SERIES:	Flanged - WGF Channel Frame - WGC	WGC
BLADE PITCH:	75mm	75
SIZE:	(mm Width x Height)	1200 x 800
OPTIONS:	Birdguard - BG Insect Screen - IS	BG
EXTRA OPTIONS:	Weather Cill - WC	WC
SPECIAL FIXING OPTIONS:	Rear Lug Fixing - RLF	RLF
BLANKING PLATE OPTIONS:	Standard - SBP Insulated - IBP	SBP
FINISH:	(Please Specify)	Mill Finish (Standard Finish)
NUMBER REQUIRED:		15

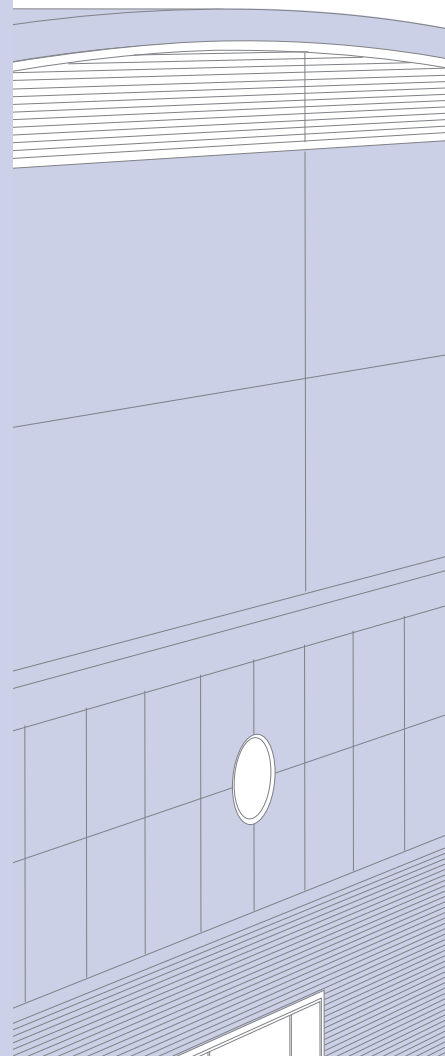



75mm PITCH LOUVRES

75mm PITCH LOUVRES

Series WG75 with its 16 SWG 75mm Pitch Louvres represents the principle building block for the Gilberts Louvre system. This unit utilises a 75mm blade, a profile which is equally suitable for both small and large Louvre Panels, allowing for a balanced appearance across a broad spectrum of sizes. The increased strength and rigidity of this blade over its 38mm counterpart combined with its physical size advantage has led to its use as the Design Basis for many of our other Louvre Products including single doors, double doors and louvre screens. In line with the smaller Louvres this series offers a high resistance to weather ingress combined with a good 50% free and both flanged and recessed channel frame options can be selected along with standard bird guard and insect screen accessories.

SERIES OPTIONS

WGF/75: Comprises of 16 SWG Louvres on 75mm centres in a 38mm wide Flanged Frame.

WGC/75: Comprises of 16 SWG Louvres on 75mm centres in a 70mm deep Channel Frame.

SIZE RANGE

Available sizes range from 300mm square up to 2000mm square in one unit. Above this size Louvres are supplied as multiple units with a continuous appearance for assembly on site.

(NB: On multiple assemblies the Frame/Flange size increases to 50mm angle).

FIXING

WGF/75: Standard method is flange screw fixing using the pre-drilled counter sunk fixing holes and screws. Alternatively flanges can be supplied un-drilled upon request, with achieved via fixing cleats located at the back of the unit.

WGC/75: Self drill tapping bolt fixing through adjustable, fixing cleat angles located at the back of the unit.

FINISH

The standard Louvre finish is mill finish (ie: un-treated). Polyester Powder Coatings, PVF and Anodised Finishes are also available on request.

LENGTH OF BLADE	VERTICAL MULLION WHEN REQUIRED
Up to 1000	None
1000 - 1600	One
Over 1600	One every 800

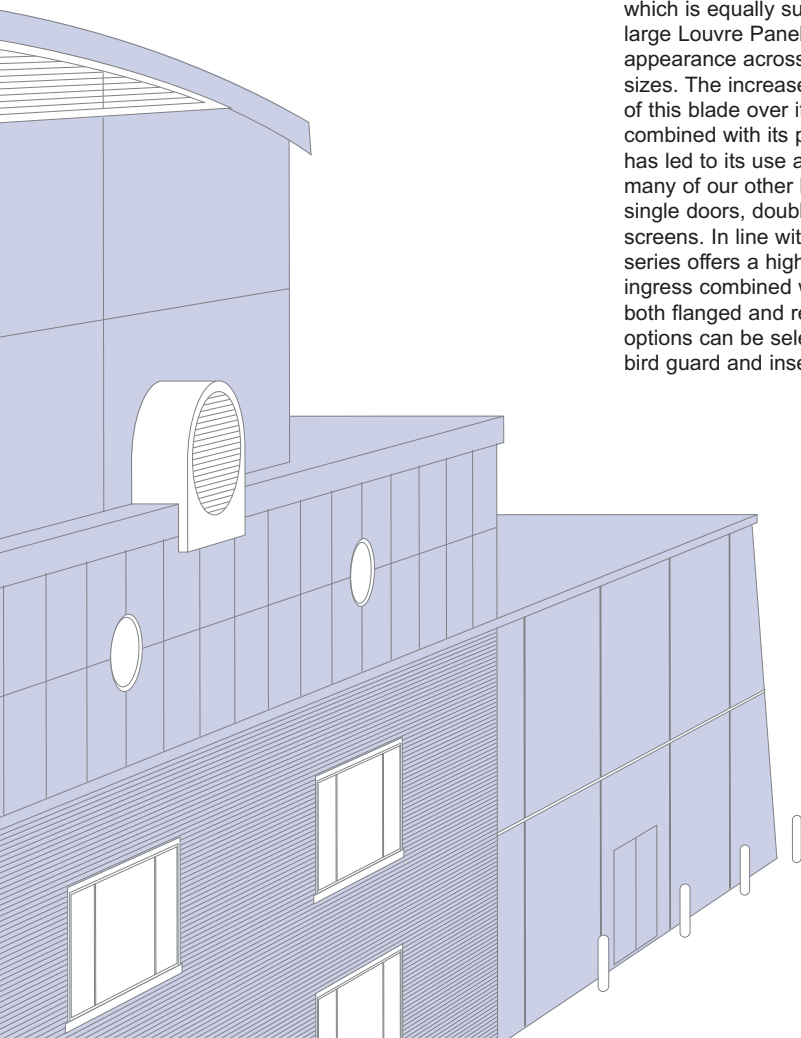



100mm PITCH LOUVRES

100mm PITCH LOUVRES

Series WG100 a 100mm Pitch Fixed Blade Unit represents the largest profile available in the Gilberts System. Utilising a 100mm heavy duty Louvre Blade the unit portrays a naturally 'Grand' appearance making it best suited for the larger Louvre applications. Manufactured from 16 SWG extrusion they are inherently strong and robust and offer good weather exclusion characteristics without sacrificing free area (50%). Both flanged and recessed channel frame borders can be selected along with optional Birdguard, Insect Screen and Weather Cill Accessories.

SERIES OPTIONS

WGF/100: Comprises of 16 SWG Louvres on 100mm centres in a 38mm wide Flanged Frame.

WGC/100: Comprises of 16 SWG Louvres on 100mm centres in a 120mm deep Channel Frame.

SIZE RANGE

Available sizes range from 600mm square up to 2500mm square in one unit. Above this size Louvres are supplied as multiple units for assembly on site.

FIXING

WGF/100: Standard method is flange screw fixing using the pre-drilled countersunk fixing holes. Flanges can be supplied un-drilled upon request.

WGC/100: Screw fixing through pre-drilled holes located on the rear lip of the Louvre frame into the surround duct, timber or masonry.

FINISH

The standard Louvre finish is mill finish (ie: un-treated). Polyester Powder Coatings, PVF and Anodised Finishes are also available on request.



LENGTH OF BLADE	VERTICAL MULLION WHEN REQUIRED
Up to 1000	None
1000 - 2000	One
Over 2000	One every 1000

WG-100 SERIES

WGF-100

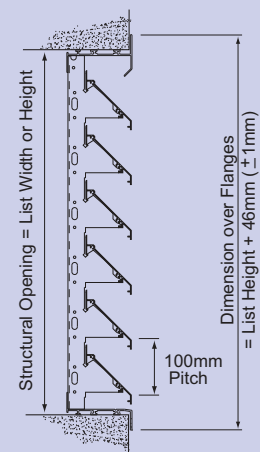
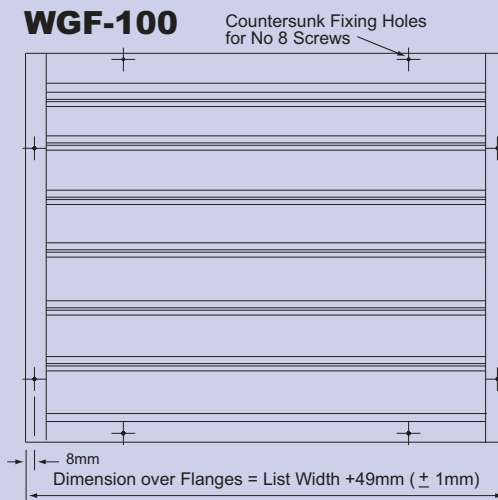

WGC-100

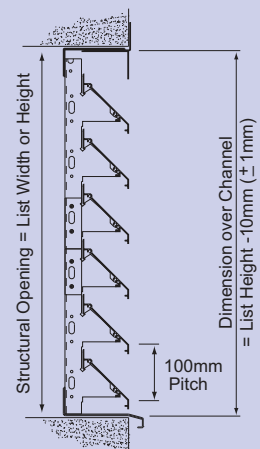

WGF-100

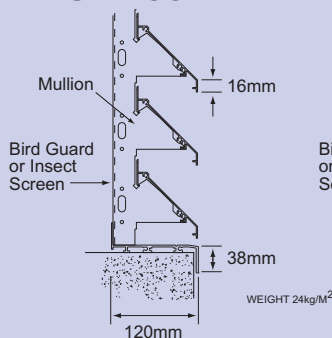

WGC-100

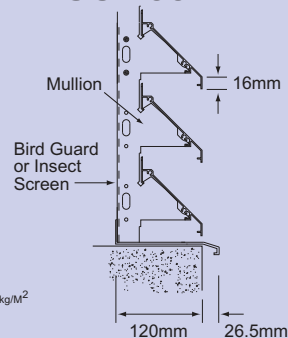

SERIES:	Flanged - WGF Channel Frame - WGC	WGC
BLADE PITCH:	100mm	100
SIZE:	(mm Width x Height)	1200 x 800
OPTIONS:	Birdguard - BG Insect Screen - IS	BG
EXTRA OPTIONS:	Weather Cill - WC	WC
SPECIAL FIXING OPTIONS:	Rear Lug Fixing - RLF	RLF
BLANKING PLATE OPTIONS:	Standard - SBP Insulated - IBP	SBP
FINISH:	(Please Specify)	Mill Finish (Standard Finish)
NUMBER REQUIRED:		15

WG 38/75/100 SERIES

FIXING DETAILS - FLANGE FRAME

Either Face Flange Fixing or Rear Mounted Angle Brackets can be selected on Flange Border Units.

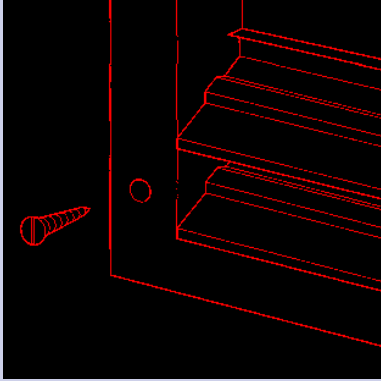

FIXING DETAILS - CHANNEL FRAME

For WG38, 75 & 100 Series Fixing Angle Cleats can be situated on the appropriate centres at the rear of the Louvre Frame drilled suitable for Expansion Bolts (up to size M8) into structure. The slotted fixing allows for any necessary adjustment to suit fixing tolerances.

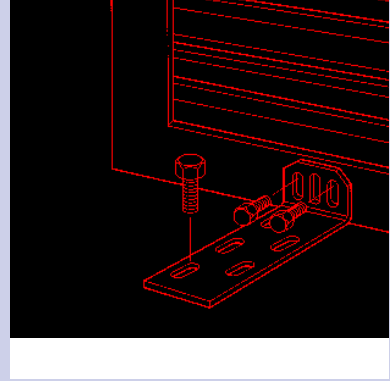

Cleats are available in 4 standard lengths; 50mm, 100mm, 150mm & 250mm and will be supplied in 3mm hot dipped galvanised mild steel. Unless otherwise stated 100mm lengths will be provided.

EXPANSION JOINTS

Where Louvres are supplied for installation by others it is advisable that Compriband seal is inserted at all joints.

Where Gilberts are installing the Louvres Compriband will be fitted.

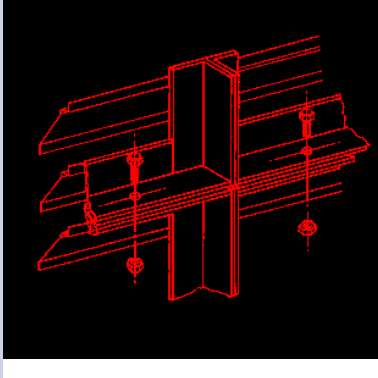

CONCEALED ANGLE

The Concealed Angle Assembly design provides for virtually invisible jointing between Louvre panels. Accurate blade alignment on the face is insured by the support clips and pre-drilled assembly holes. Provision for Louvre expansion can also be made by applying Compriband Sealing/Expansion between the angles. (WG75 shown).

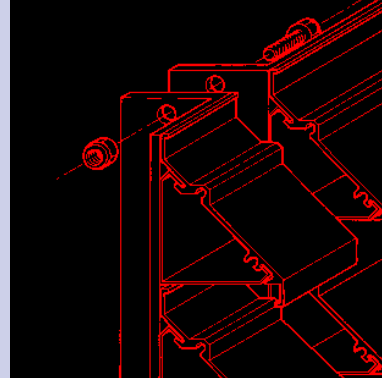

VERTICAL ASSEMBLY

For assembly of vertical panels a reversed angle feature is utilised as illustrated. This provides for a invisible joint whilst maintaining the correct blade pitch. (WG75 shown).

38/75/100mm CONTINUOUS LOUVRES

CONTINUOUS LOUVRE

For applications where larger Louvre assemblies are required such as for wall or rooftop screening and ventilation applications our Series WG38, 75 and 100 can be supplied any size in multiple panels, purpose built to assemble into a continuous Louvre Screen. Despatched with all the necessary fixing angles and bolts for their assembly the panels can be banked both horizontally and vertically and designed to incorporate additional features such as:

- **Internal/External Mitred Corners**
- **Dummy, Blanked and Active Sections**
- **Horizontal and Vertical Blade Sections**
- **Single and double Hinged Continuous Appearance Doors**

Unusual and irregular profiles can typically be catered for with accurate face alignment provided by the pre-fixed assembly holes and blade alignment pieces. Rear mounted Mullion Supports are provided for additional strength where required.

Our standard fixing and assembly details are illustrated herein. The individuality and

complexity of continuous screening applications will however require, in each case, the preparation of detailed manufacturing drawings to ensure that the unit not only meets all the clients requirements but is also easy to assemble, install and fix on site. Our Company has been specially tailored to provide this all inclusive service with:

- **Initial Site Surveys to obtain construction work details**
- **Preparation of detailed manufacturing drawings in accordance with the clients requirements and the results of the initial Survey**
- **Final manufacture and appropriate finishing to blend or contrast, as required with the building structure**
- **Expert Site installation by our own team of skilled engineers**

In this way a thorough and trouble free installation can be insured and our Louvre Team will be pleased to give any advice or guidance you may require for a particular application.



LOUVRE DOORS

LOUVRED DOORS

For applications where ventilation and access is required to Plant Room or Generator equipment Gilberts single and double leaf, inward or outward opening, Louvred Doors can provide an ideal solution. Designed for use both as stand alone units with Border Frame, or as part of a continuous Louvre Screen they constitute ready made units complete with all necessary accessories such as Door Stays, Mortice Locks, Barrel Bolts and, if required Birdguard or Insect Screens

CONTINUOUS SCREEN DOORS

For use in continuous screens Louvre Doors incorporate a blade appearance **frame** and concealed pivot style hinges. This ensures that the continuous line of the Louvre is not compromised in any way. The standard blade profile is the 75mm unit as used on Series WG75 however 38 and 100mm pitches are available.

SERIES OPTIONS

WDS/75: Single Hinged Louvre Door comprising 16 SWG Louvres on 75mm Centres

WDD/75: Double Hinged Louvre Door comprising 16 SWG Louvres on 75mm Centres

FIXING

Two alternative fixing methods are available on WD Louvred Doors as detailed.

FINISH

The standard Louvre finish is mill finish (ie: un-treated). Polyester Powder Coatings, PVF and Anodised Finishes are also available on request.

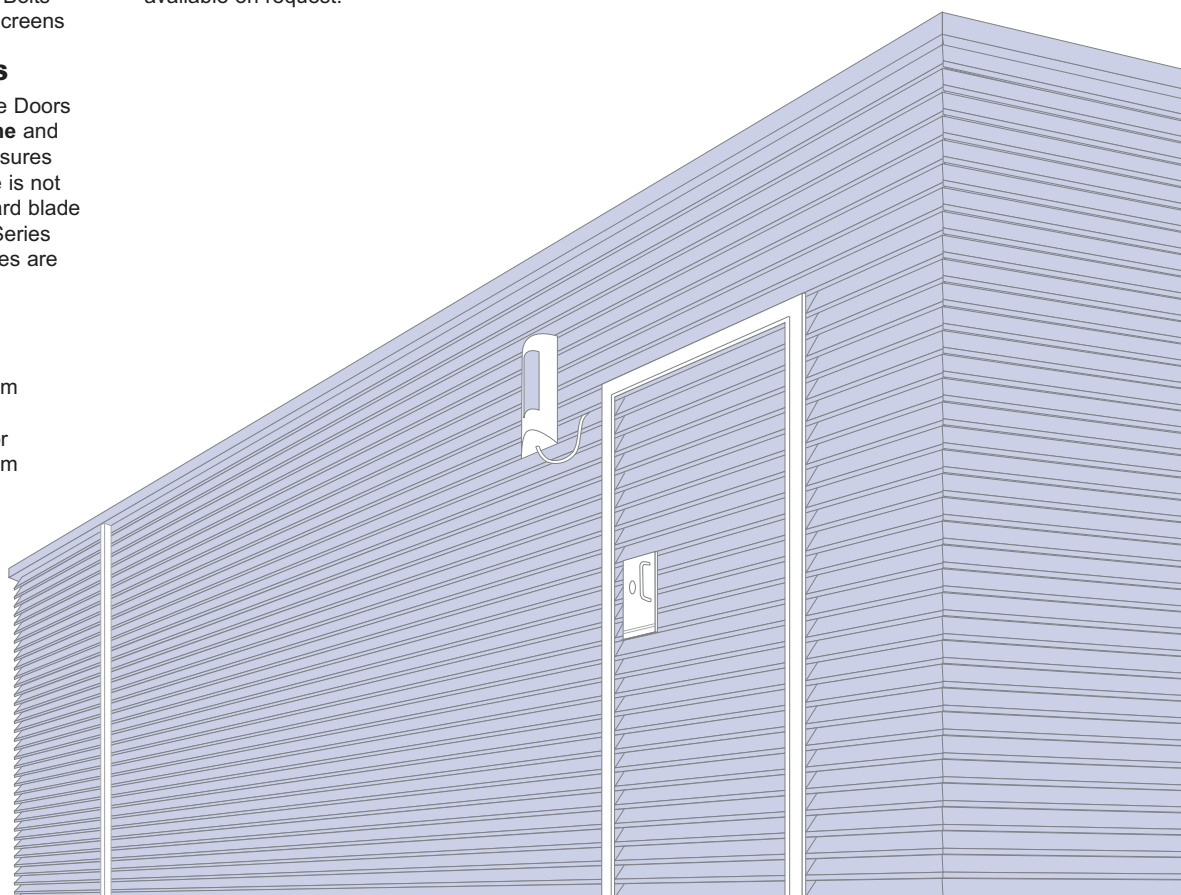

WD SERIES

WDS-75

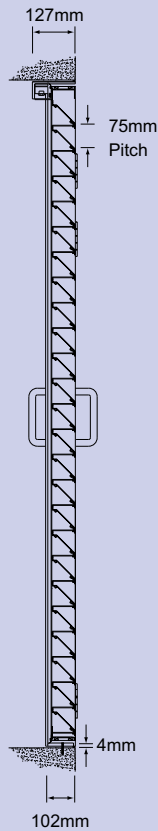
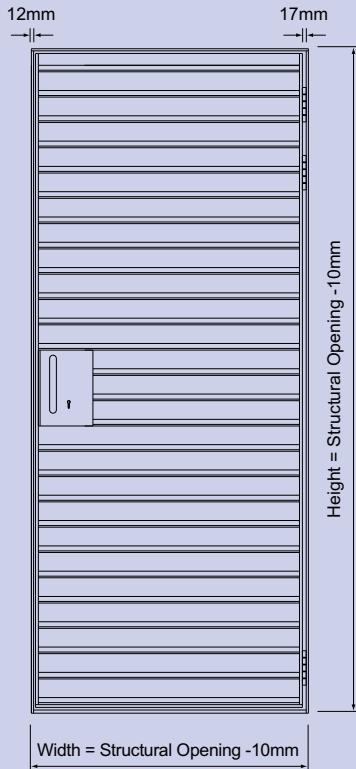

SIZE RANGE

WDS/75 (SINGLE DOOR): Standard door panel to fit aperture openings 400 x 600 up to 1000 x 2100 angle. Leaf size = aperture opening -40 on width and -33 on height.

WDD/75 (DOUBLE DOOR): Standard door panel assembly to fit structural openings 1200 x 600 up to 2000 x 2100 angle. Leaf size = aperture opening -40 on width, and -33 on height. Clear opening = aperture width -112 and height -72

Note: For doors greater than listed sizes a 75 x 38mm box section outer frame is used to provide sufficient design rigidity.

WDD-75

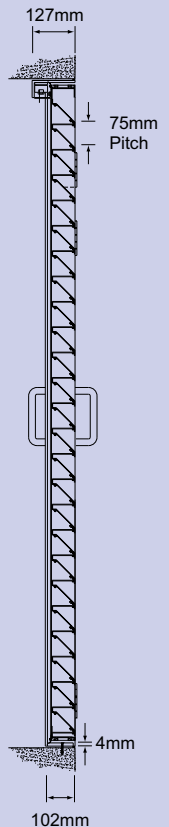
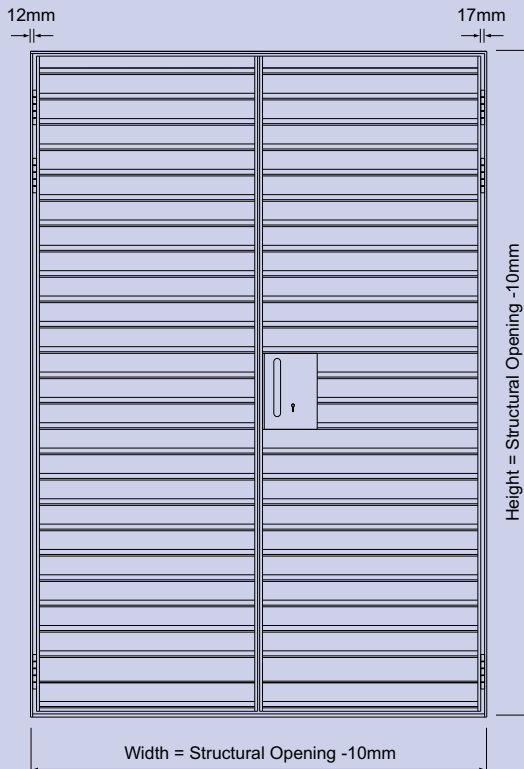

FIXING ARRANGEMENT A

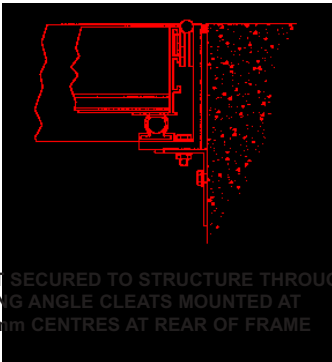

UNIT SECURED TO STRUCTURE THROUGH FIXING ANGLE CLEATS MOUNTED AT 600mm CENTRES AT REAR OF FRAME

FIXING ARRANGEMENT B

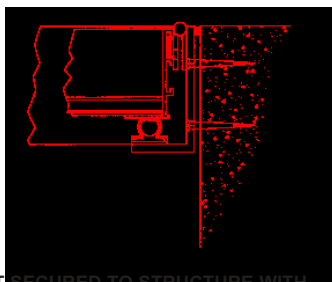

UNIT SECURED TO STRUCTURE WITH No.12 COUNTERSUNK SCREWS ON 600mm CENTRES THROUGH THE FRAME

SERIES:	Narrow Border - WFD Wide Border - WBD	WFD
DOOR:	Single - S Double - D	S
BLADE PITCH:	75mm	75
SIZE:	(mm Width x Height)	1200 x 800
OPTIONS:	Birdguard - BG Insect Screen - IS	BG
OPENING DETAILS:	Inward Opening - IO Outward Opening - OO	IO
HINGE DETAILS (Single door):	Left hand Hinge - LH Right Hand Hinge - RH	LH
DOOR FIXING ARRANGEMENT:	A or B	A
FINISH:	(Please Specify)	Mill Finish (Standard Finish)
NUMBER REQUIRED:		15

PH SERIES

PH-38



PH-75

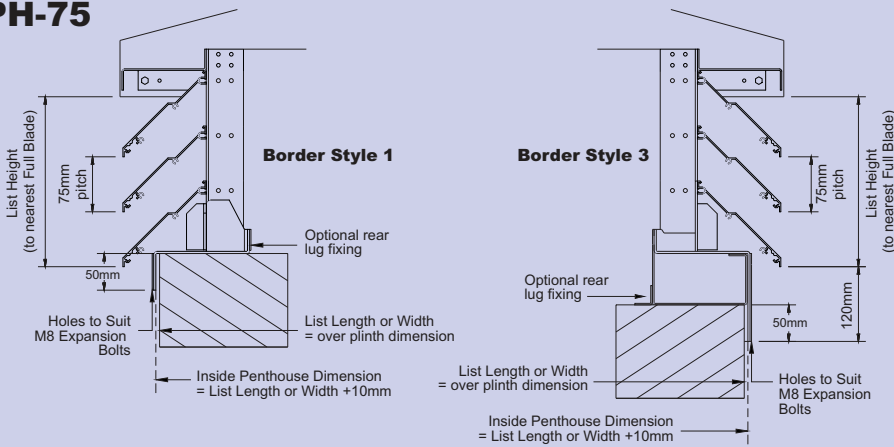

PH-100

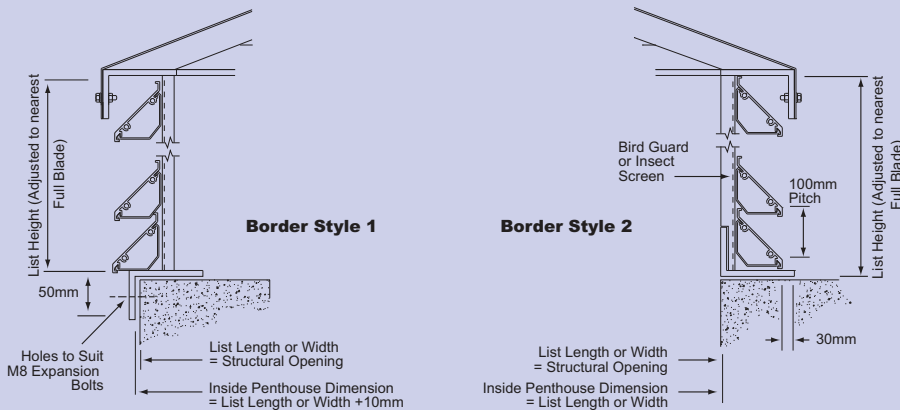

SERIES:	PH	PH
BLADE PITCH (mm):	38, 75, 100	75
SIZE:	(mm Length x Width x Height)	1200 x 1200 x 800
OPTIONS:	Insect Screen - IS	IS
BASE BORDER STYLE:	Border Style 1 - B1 Border Style 2 - B2 Border Style 3 - B3	B1
FINISH:	(Please Specify)	Mill Finish (Standard Finish)
NUMBER REQUIRED:		15

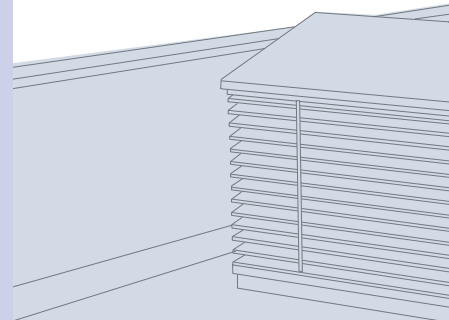



PENTHOUSE LOUVRES

PENTHOUSE LOUVRES

The PH Series is a range of roof mounting fixed Blade Louvre Housings suitable for air intake or discharge over ventilation shafts etc. The units are available in 3 blade formats based upon the WG Series of Louvre Panels and are supplied complete with continuous corners, removable sloping roof and birdguards. Supplied with alternative fixing borders to suit plinth or flat roof mounting the units offer a 50% free area performance combined with good weather characteristics.

SERIES OPTIONS

PH/38: Comprises of 16 SWG Aluminium Louvres on a 38mm Pitch with rear mounted Birdguard screen. Insect screens available as an optional extra.

PH/75: Comprises of 16 SWG Aluminium Louvres on 75mm Pitch with rear mounted Birdguard screen. Insect screens available as an optional extra.

PH/100: Comprises of 16 SWG Aluminium Louvres on 100mm Pitch with rear mounted Birdguard screen. Insect screens available as an optional extra.

SIZE RANGE

Available sizes range from 300x300x300mm upwards. for maximum unit sizes in one piece please refer to head office. Multiple assemblies can be supplied upon request

FIXING

The PH Series Penthouse Louvres are available with two types of base border options to suit either plinth or flat roof mounting. These borders are supplied with fixing holes to suit M8 expansion bolts on standard 600mm centres. Other fixing details available to order.

FINISH

The standard Louvre finish is mill finish (ie: un-treated). Polyester Powder Coatings, PVF and Anodised Finishes are also available on request.

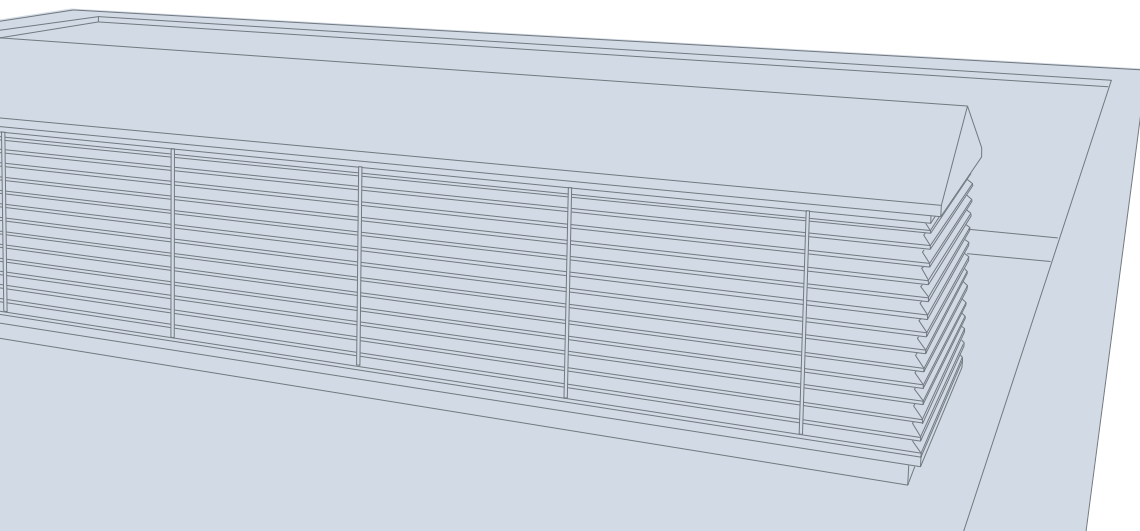



SPECIAL LOUVRES

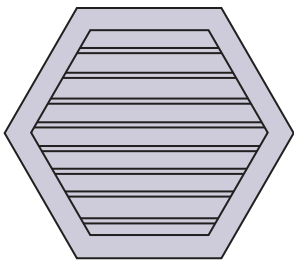

HEXAGONAL

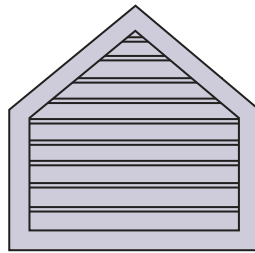

POLYGONAL

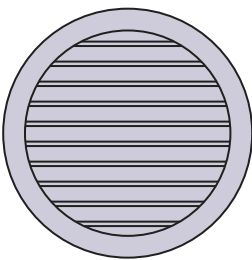

CIRCULAR

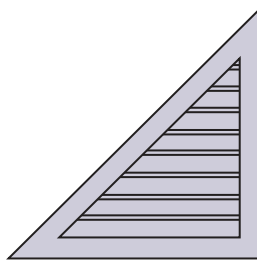

RIGHT ANGLE TRIANGLE

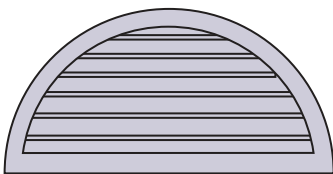

SEMI-CIRCULAR

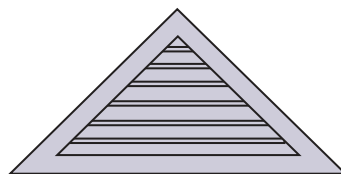

EQUILATERAL TRIANGLE

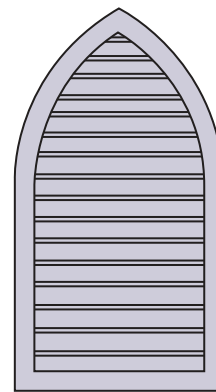

ARCHED

In addition to standard, square and rectangular patterns Gilberts can also fabricate special louvres to almost any practical design.

Circular, semi-circular and triangular designs are popular selections however other more unusual profiles such as gothic arch, polygon and even hexagonal have been supplied. For that special application in 38, 75 and 100mm pitch profiles please contact our louvre sales office.

SIZING NOMOGRAM

WG-38/75/100 SERIES

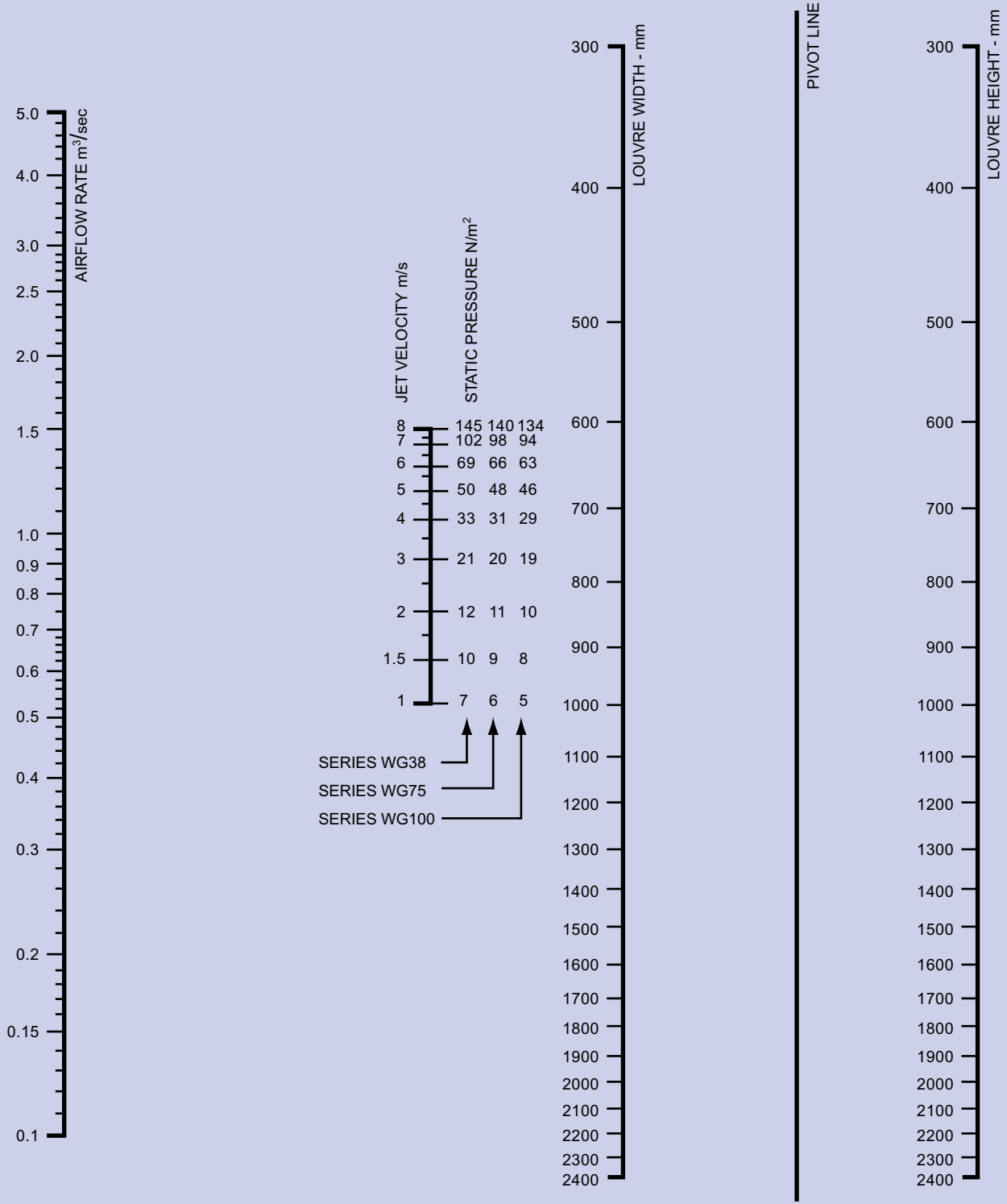

INTEGRATED LOUVRE SYSTEMS

OTHER RANGES AVAILABLE INCLUDE:

- HIGH PERFORMANCE LOUVRES
- MOVABLE BLADE LOUVRES
- SITE ASSEMBLY LOUVRES
- ACOUSTIC LOUVRES



GILBERTS
(BLACKPOOL LTD)

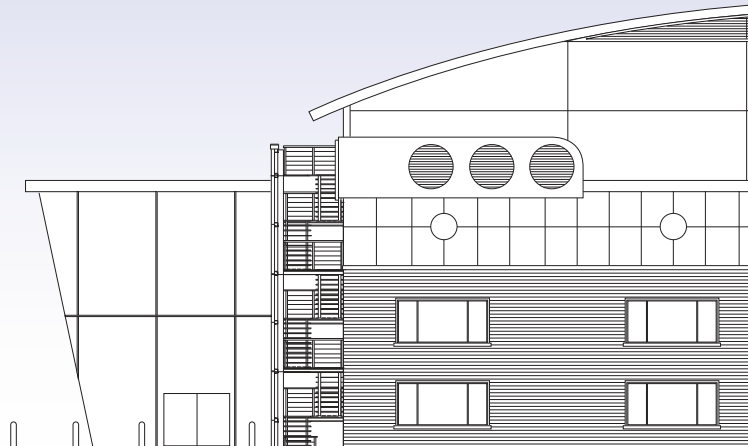

Clifton Road, Blackpool FY4 4QT Telephone: 01253 766911 Fax: 01253 767941
Email: louvres@gilbertsblackpool.com Web: www.gilbertsblackpool.com

Gilberts (Blackpool) Ltd reserve the right to alter the specification without notice. For our latest product data please visit www.gilbertsblackpool.com
The information contained in this leaflet is correct at time of going to press 2016.

