

CG - Circular Attenuators

With End Rings

Circular duct attenuator, constructed from spiral wound or plain galvanised sheet steel, with a peripheral out of airstream acoustic lining. Casing provided with end rings suitable for direct connection to circular fans or flanged ducts. End rings have threaded inserts to enable quick installation.

Options available:

- Central pod for increased performance
- Melinex wrapped infill
- Internal and external paint finish

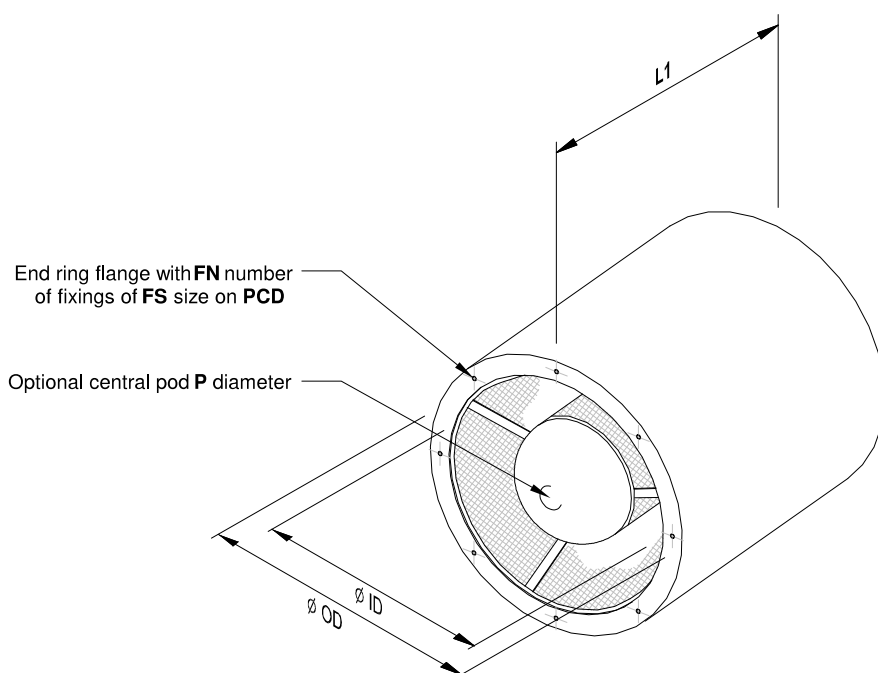

Available Sizes

Internal Diameter ID	Outside Diameter OD	Pod Diameter P	Lengths in 300mm Increments L1				Lengths based on ID L1			Hole Pattern A			Hole Pattern B		
										FN	FS	PCD	FN	FS	PCD
315	405	170	600	900	1200	1500	315	473	630	8	M8	355	8	M8	355
355	455	170	600	900	1200	1500	355	533	710	8	M8	395	8	M8	395
400	505	210	600	900	1200	1500	400	600	800	8	M10	450	12	M8	438
450	605	210	600	900	1200	1500	450	675	900	8	M10	500	12	M8	487
500	635	265	600	900	1200	1500	500	750	1000	12	M10	560	12	M8	541
560	715	265	600	900	1200	1500	560	840	1120	12	M10	620	16	M10	605
630	805	335	600	900	1200	1500	630	945	1260	12	M10	690	16	M10	674
710	905	335	600	900	1200	1500	710	1065	1420	16	M10	770	16	M10	751
800	1005	420	600	900	1200	1500	800	1200	1600	16	M10	860	24	M10	837
900	1125	420	600	900	1200	1500	900	1350	1800	16	M12	970	24	M10	934
1000	1255	500	600	900	1200	1500	1000	1500	2000	16	M12	1070	24	M10	1043

All units suitable for medium pressure systems.

Larger sizes up to 2000mm diameter are available, details upon request.

These units are also available with an end ring on one end and a 50mm long spigot on the other end.