

SECOND FLOOR REAR  
PLANS & ELEVATIONS 1:20

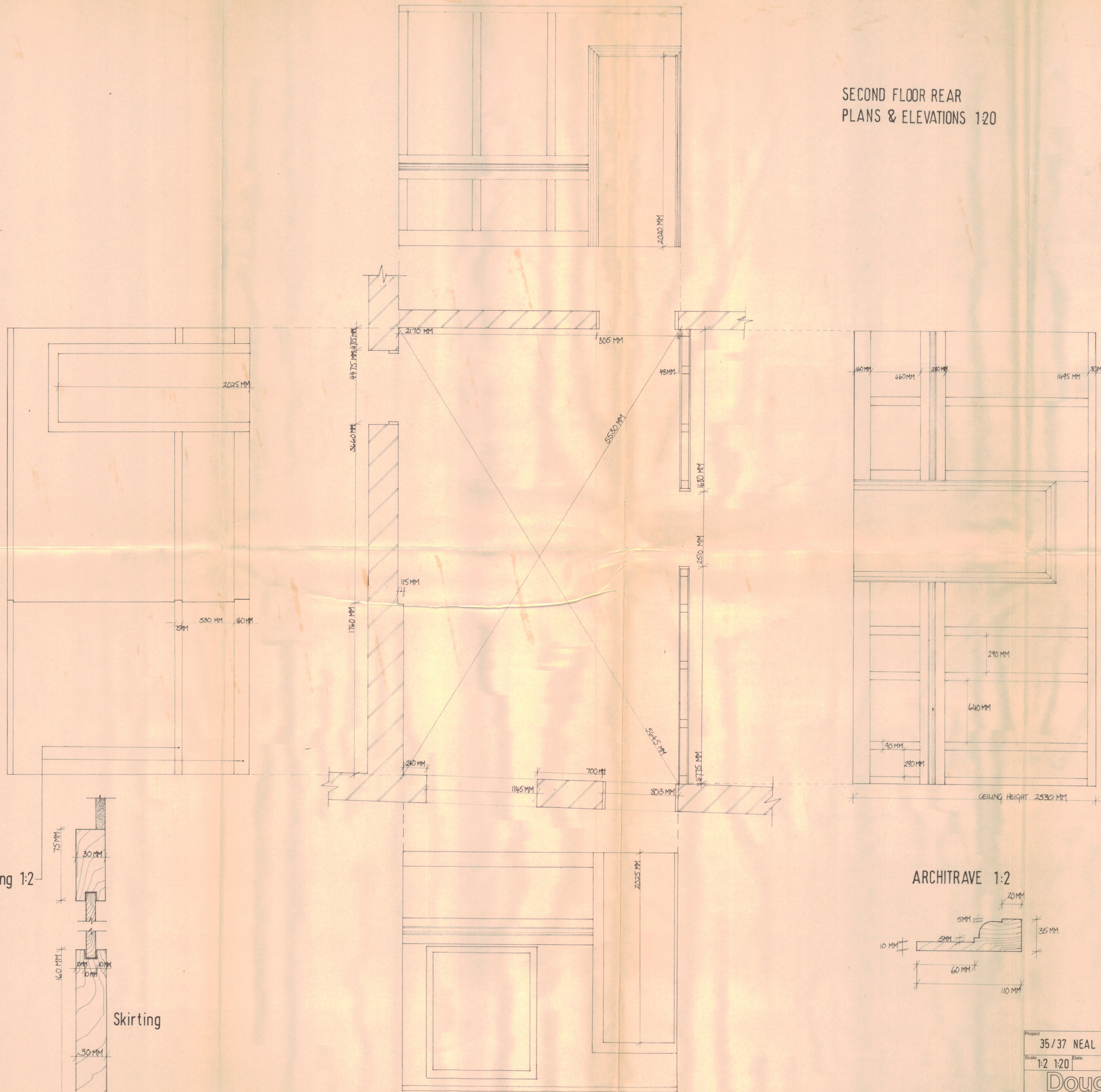

Skirting & Handrail detail 1:2

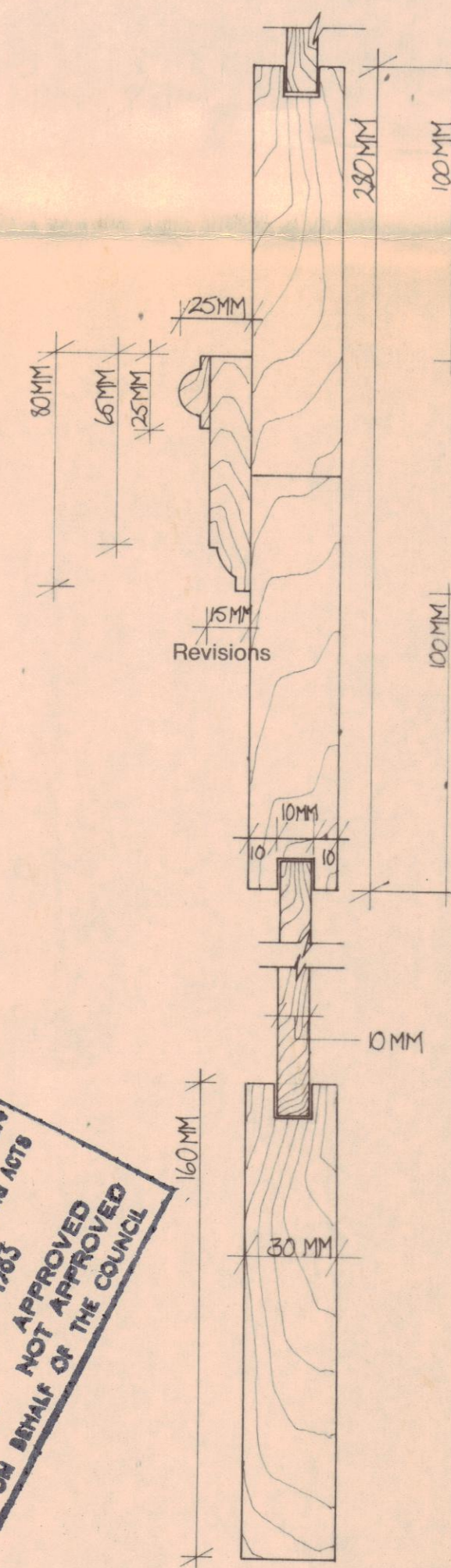

Panelling fixing 1:2

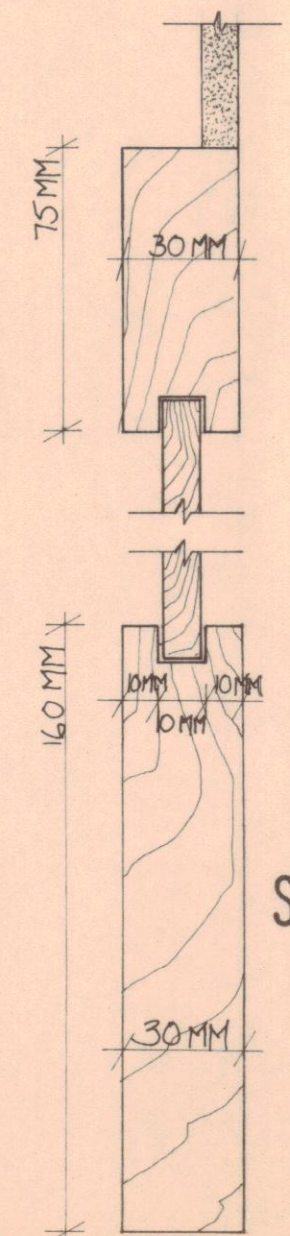

Skirting

ARCHITRAVE 1:2

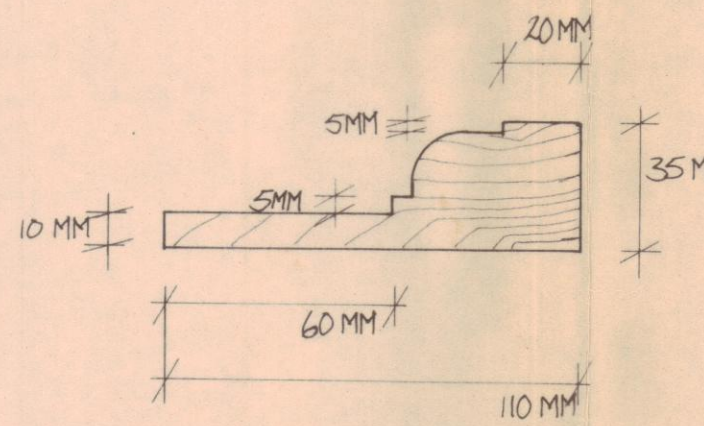

SCHEMATIC DIVISION OF CAMPDEN  
TOWN AND COUNTRY PLANNING ACTS  
12 OCT 1985  
APPROVED  
PLANS NOT APPROVED  
ON BEHALF OF THE COUNCIL

CTP/114/55/9 #B3162

Project	35/37 NEAL STREET WC2	Title	PANELLING DETAILS.
Scale	1:20	Job No	232
Drawn		Drawing No	E-16
Douglas Paskin Associates			
7 Cliff Road Studios London NW19AN 01-485 1114			