

- NOTES:
- Do not scale from drawing, use figured dimensions only
 - All dimensions to be checked onsite
 - This drawing to be read in conjunction with all other Gillespies drawings and specifications
 - For General Arrangement Landscape Plan, refer to KXC-A-001-L-GIL-00-11201
 - For Hard Materials, refer to KXC-A-001-L-GIL-00-11211 / 11212 / 11213 / 11214 / 11215
 - For Walls and Edges, refer to KXC-A-001-L-GIL-00-11221 / 11222 / 11223 / 11224 / 11225
 - For Overall Levels Plan, refer to KXC-A-001-L-GIL-00-11202
 - For Detailed Levels, refer to KXC-A-001-L-GIL-00-11231 / 11232 / 11233 / 11234 / 11235
 - For Landscape Roof specifications refer to KXC-A-001-L-GIL-90-SP001
 - For interface details with RE9 Edge, refer to KXC-A-001-L-GIL-90-50058
 - For Lighting bench details, refer to BDP's drawing KXC-A-001-J-BDP-63-50001
 - For Roof Services layouts, refer to KXC-A-001-L-GIL-90-11291 - KXC-A-001-L-GIL-90-11295

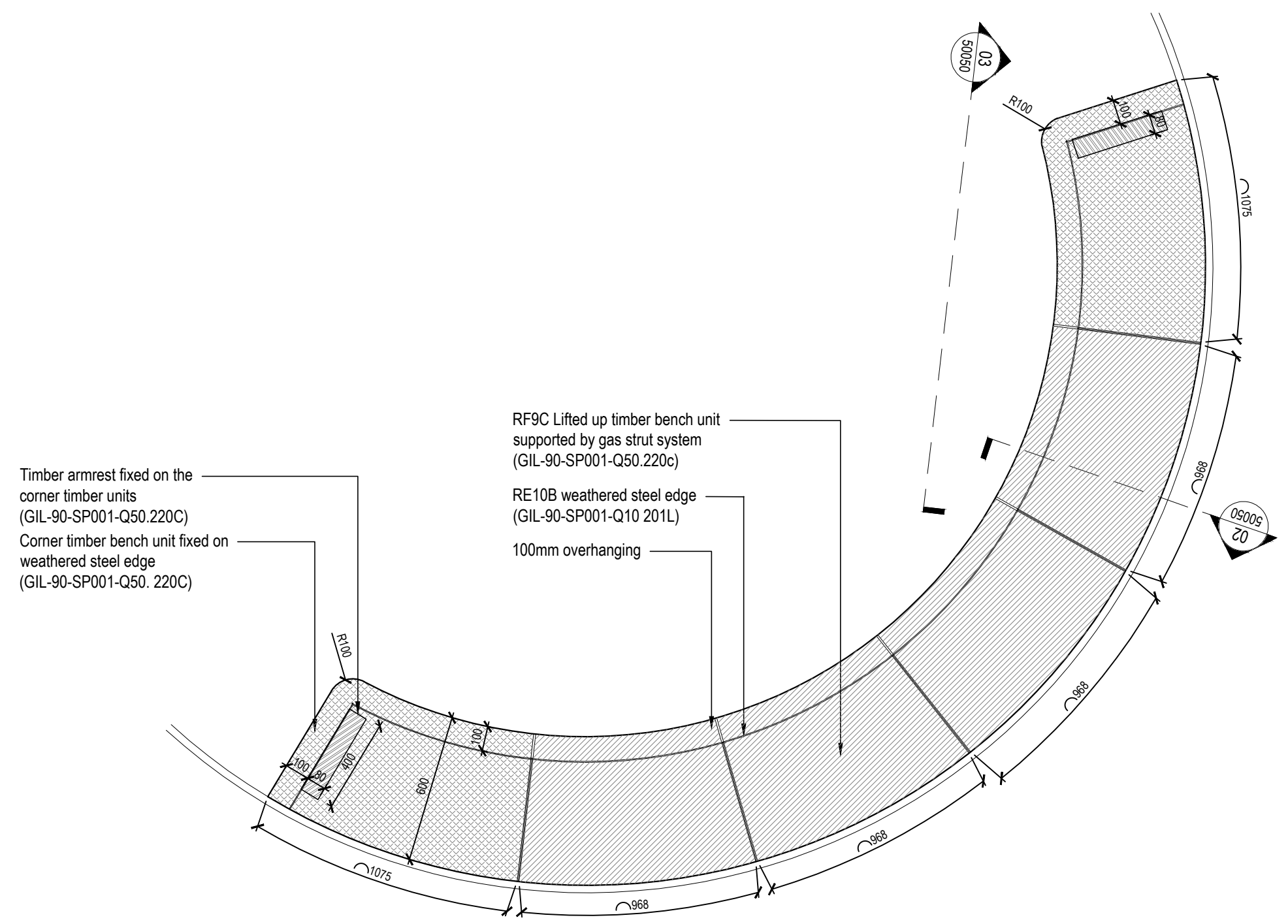

01 Typical Edge Type RE10B (450mm Bench Edge) - Plan
Scale 1:20 @ A1

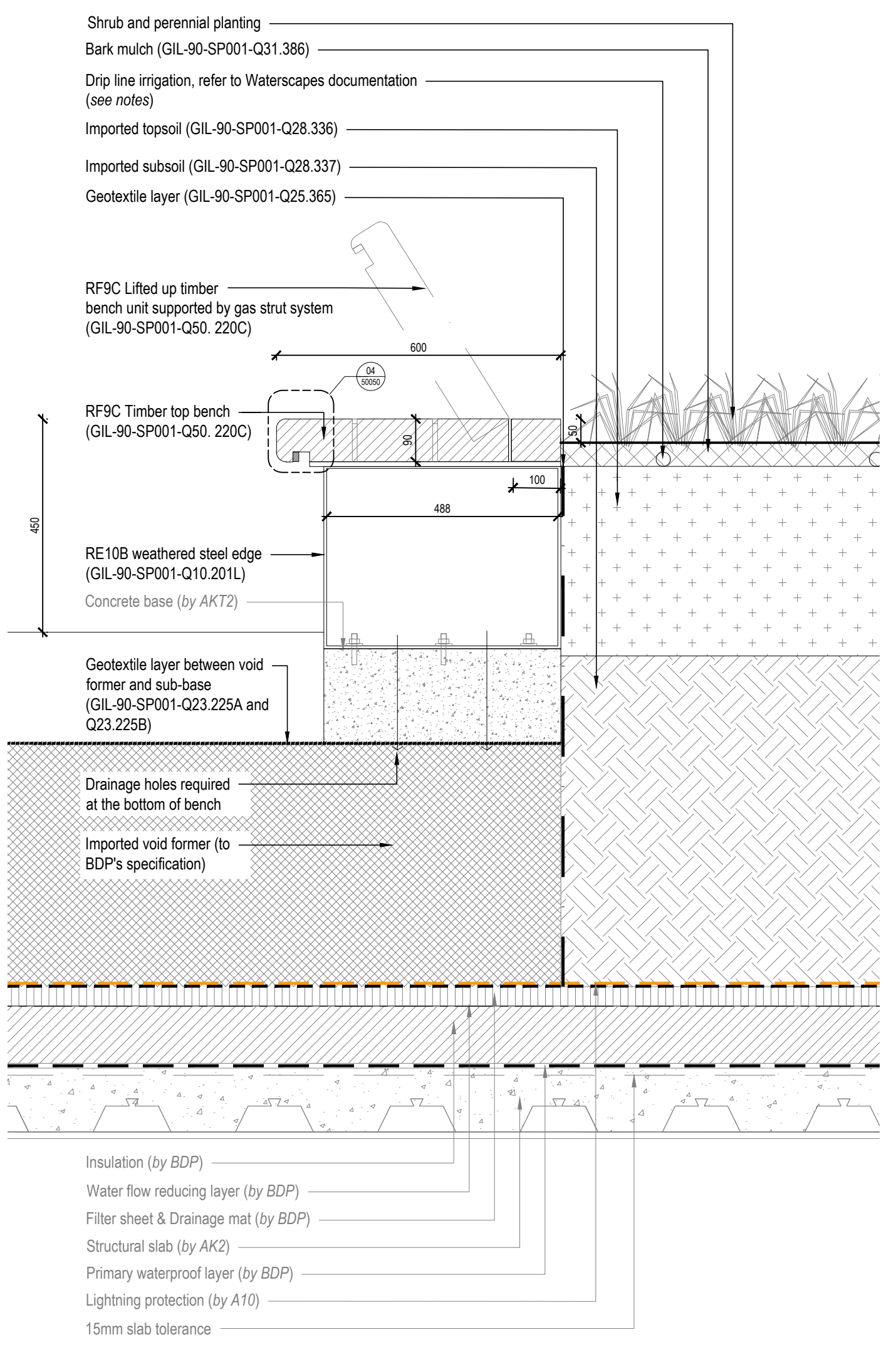

02 Typical Edge Type RE10B (450mm Bench Edge) - Section
Scale 1:10 @ A1

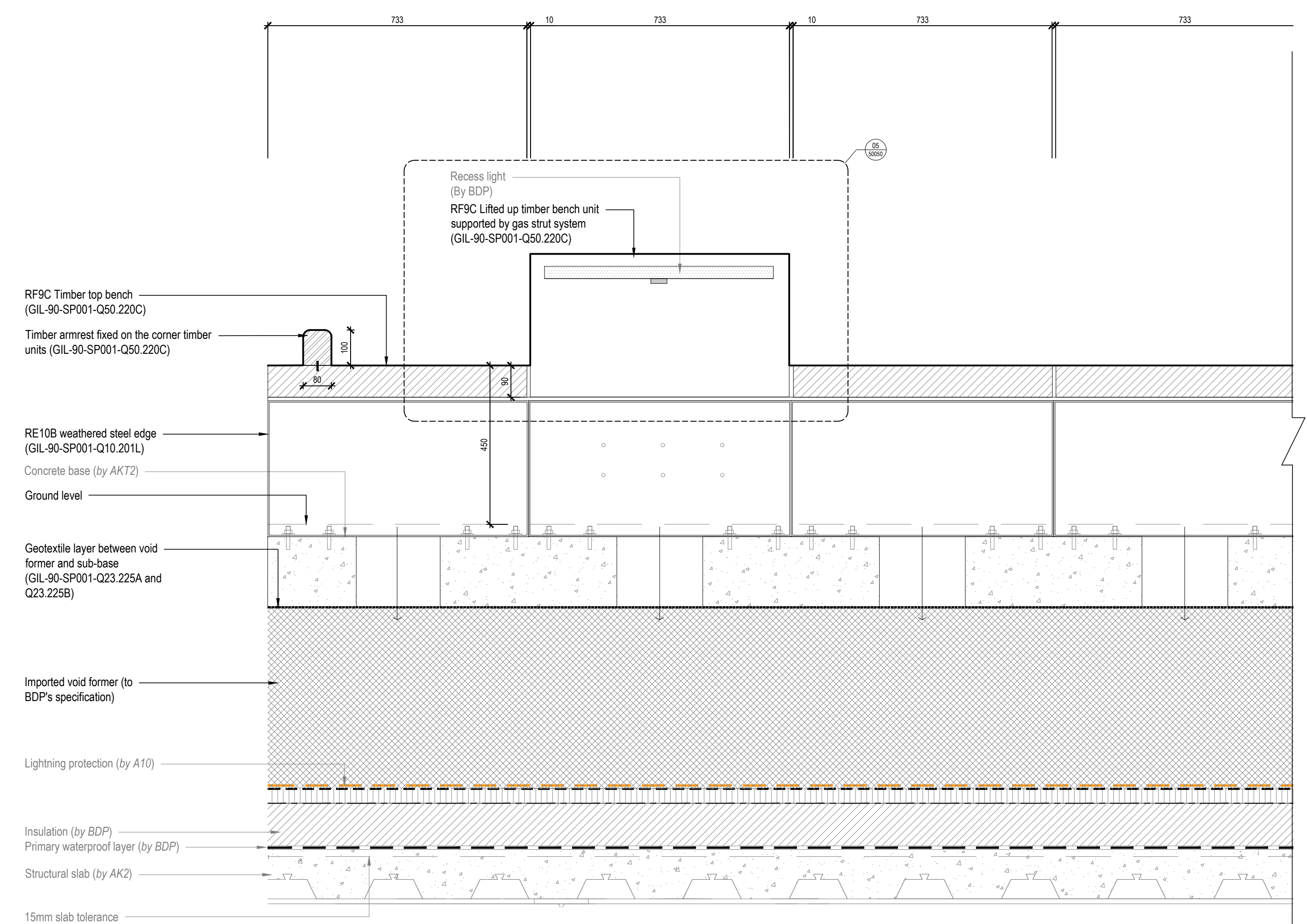

03 Typical Edge Type RE10B (450mm Bench Edge) - Elevation
Scale 1:10 @ A1

NOTE:
SHOP DRAWINGS WILL BE REQUIRED FOR ALL WEATHERING STEEL EDGES AND APPROVED BY EMPLOYER

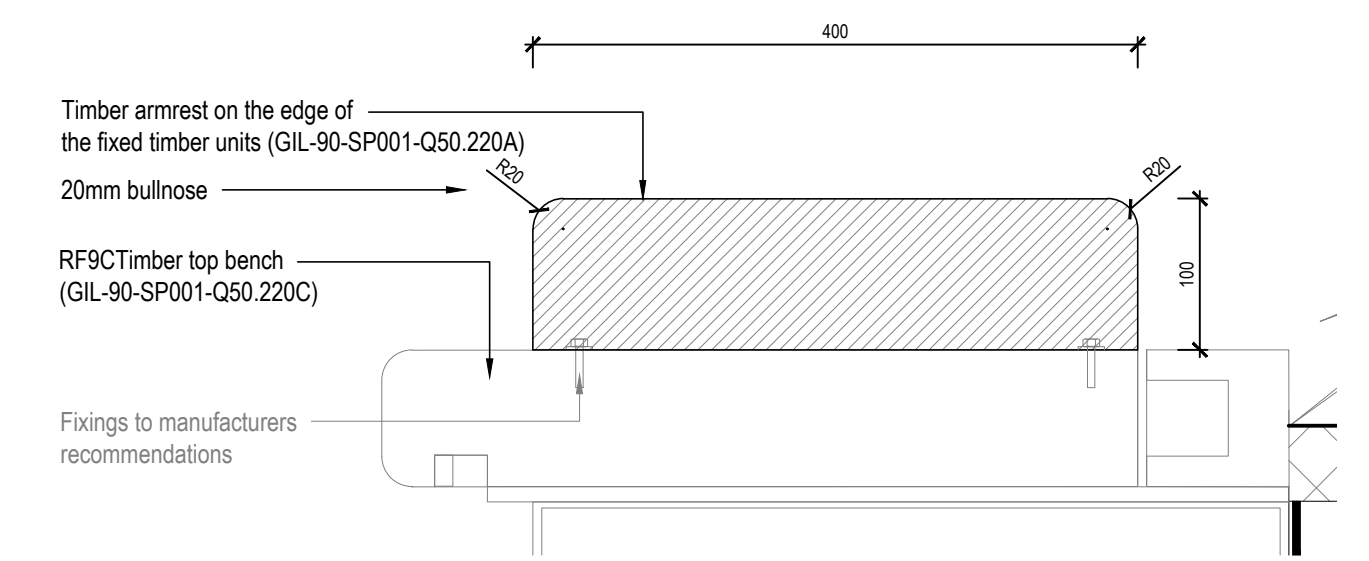

06 Typical Edge Type RE10B - Armrest - Section
Scale 1:5 @ A1

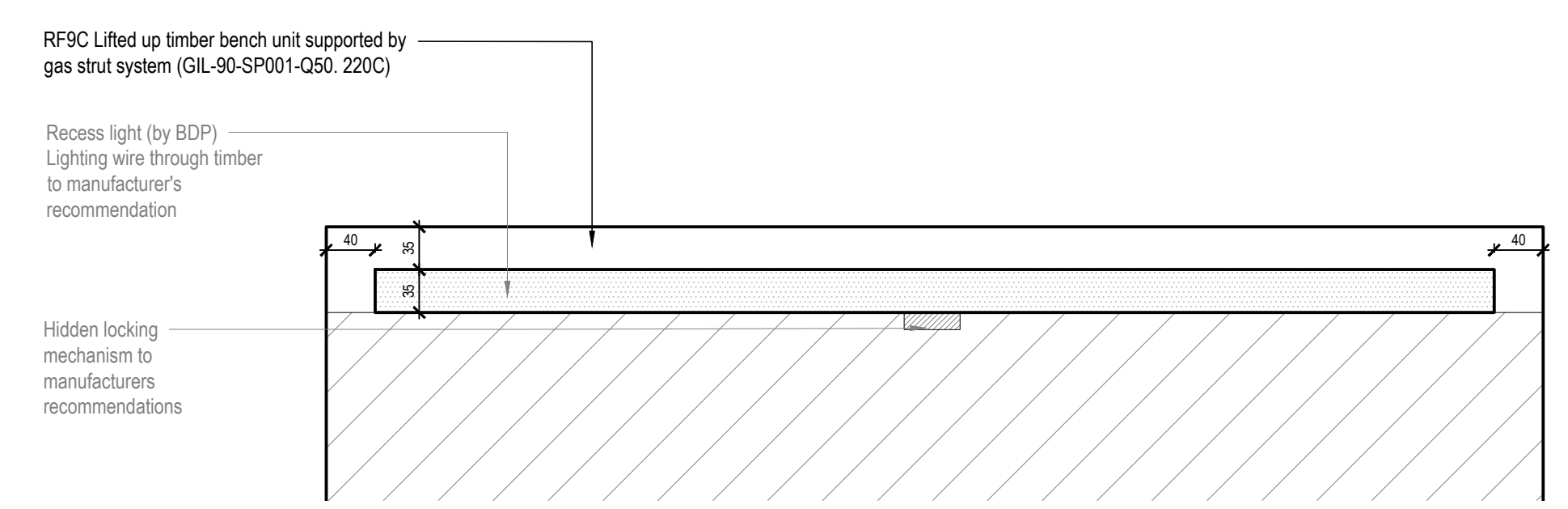

05 Typical Edge Type RE10B - Recess light under timber unit - Elevation
Scale 1:5 @ A1

NOTE:
For Roof Bench Schedule, refer to KXC-A-001-L-GIL-00-SH002
Allow for 50% of units to be openable
Access to timber bench storage will be lockable

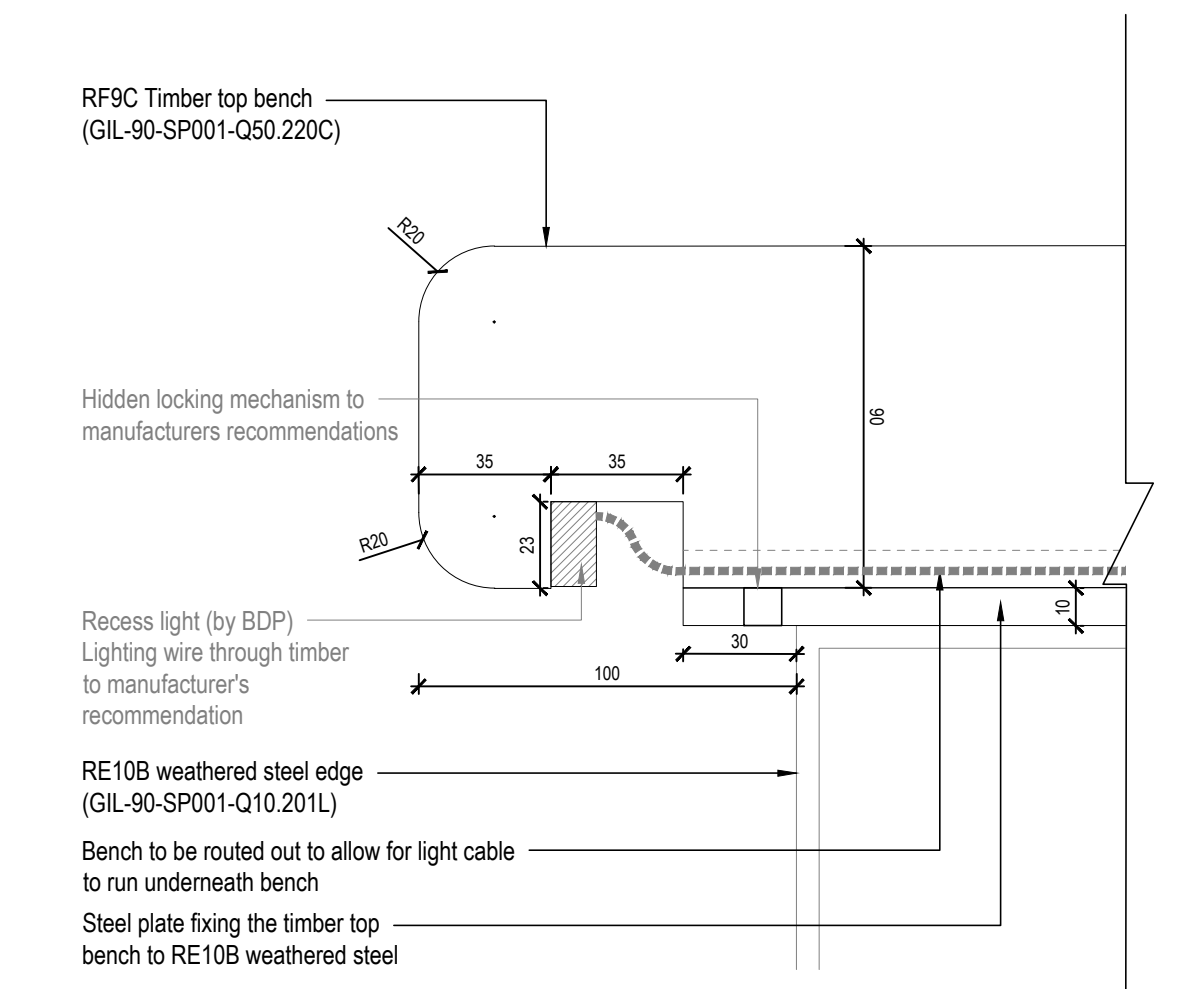

04 Typical Edge Type RE10B - Recess light - Section
Scale 1:2 @ A1

T01	For Tender (CRF 183)	SH	AM	14.10.19
P01	Issued for Stage 3	CD	AM	25.01.17

GILLESPIES

1 St John's Square, London EC1M 4EH
P: 020 7253 2929 F: 020 7253 3900 E: design.london@gillespies.co.uk

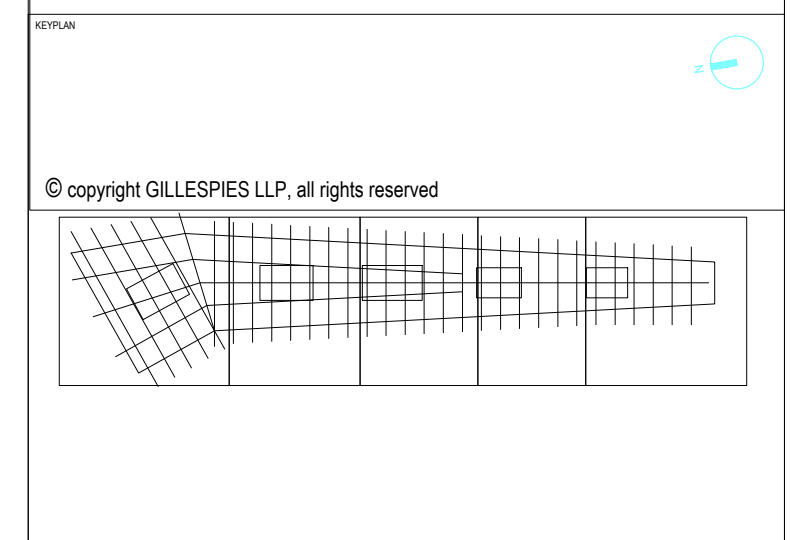

Revision	Description	Drawn	Checked	Date