

Internal Room Elevation

Scale: 1:10

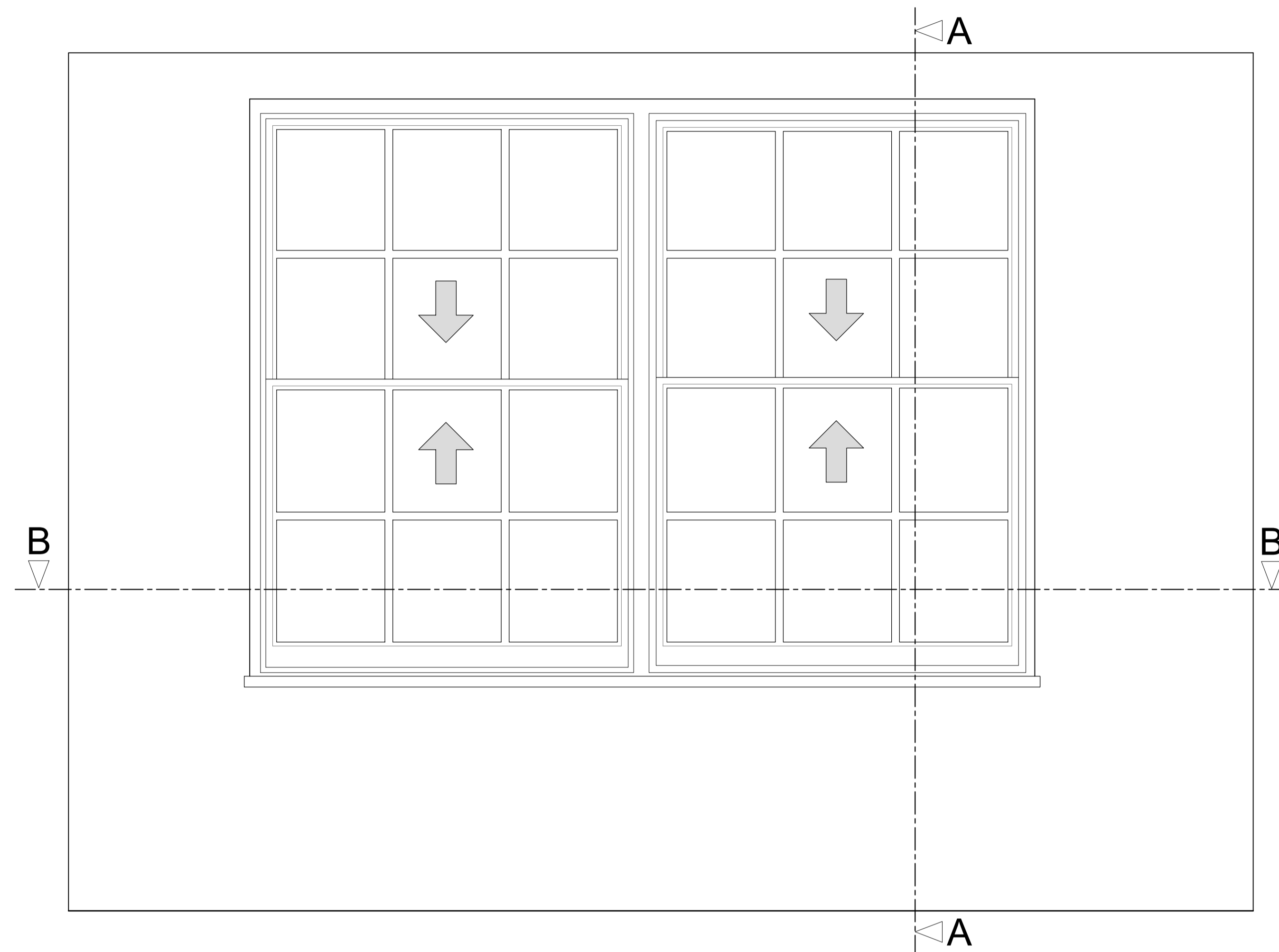

Section A-A through External Wall

Scale: 1:10

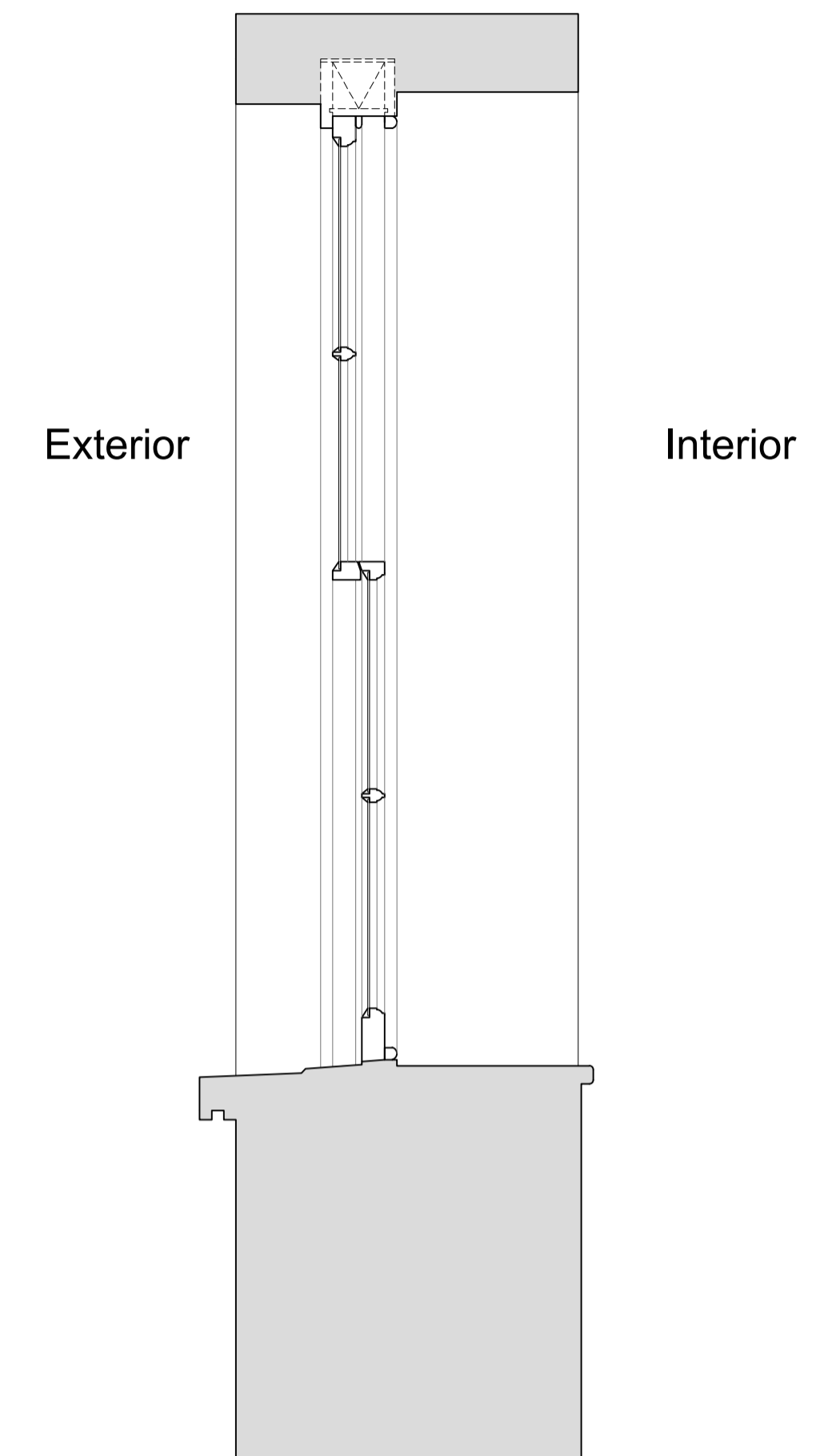

Plan Section B-B

Scale: 1:10

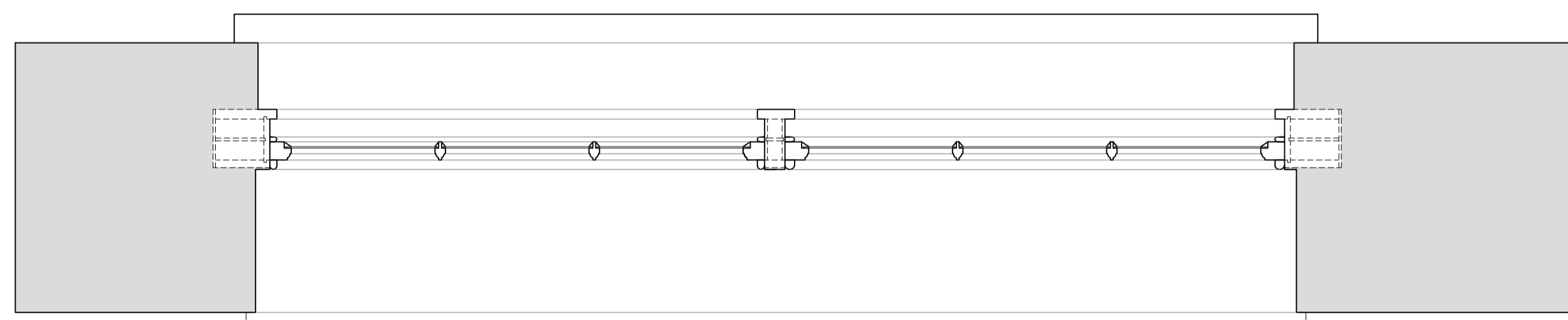

Revision	Date	Assessment
1.0	25-01-2021	Issued for listed building consent application

Do not reproduce this drawing without written permission  
All dimensions are in millimetres unless stated otherwise

Drawing Not For Construction

**HS2**

High Speed (HS2) Limited  
1st-3rd Floor  
The Podium  
1 Eversholt Street  
London NW1 2DN

**COSTAIN SKANSKA**

Costain Skanska Joint Venture  
9th Floor  
The Tower  
1 Eversholt Street  
London NW1 2DN

Site Address:  
47 Mornington Terrace, London NW1

Drawing Title:  
Basement - Lounge: EXISTING Window Joinery Details -  
Sheet 1 of 3

Drawn by: AP & PB      Checked by: OB      Presentation Scale: as shown @ A1

Date: 29-04-2019      Drawing No: WPI P066 NI - 47 MT-EX-BS-J-01      Revision: 1.0

Internal Room Elevation with Secondary Glazing Installed

Scale: 1:10

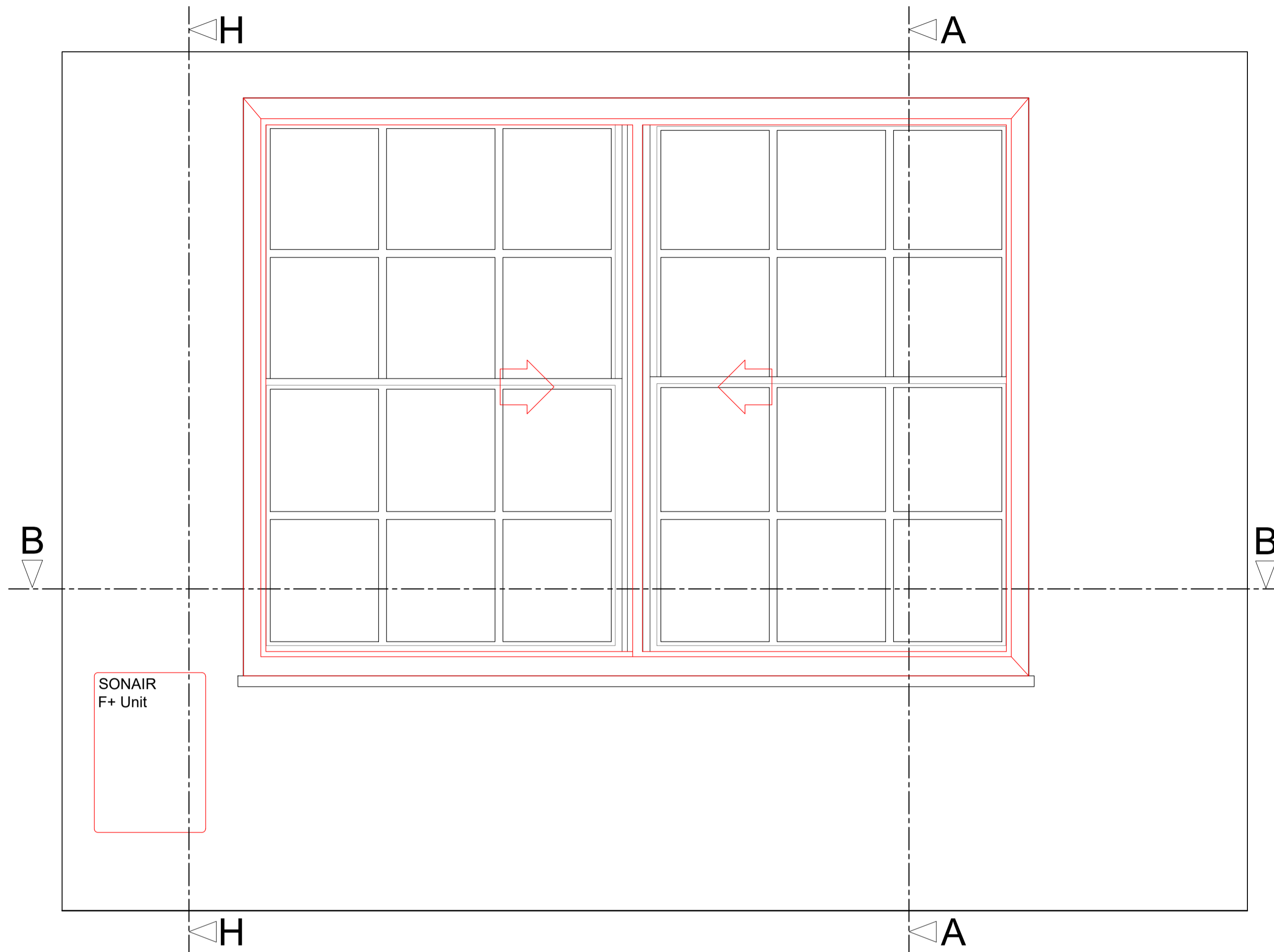

Section A-A through External Wall with Secondary Glazing Installed

Scale: 1:10

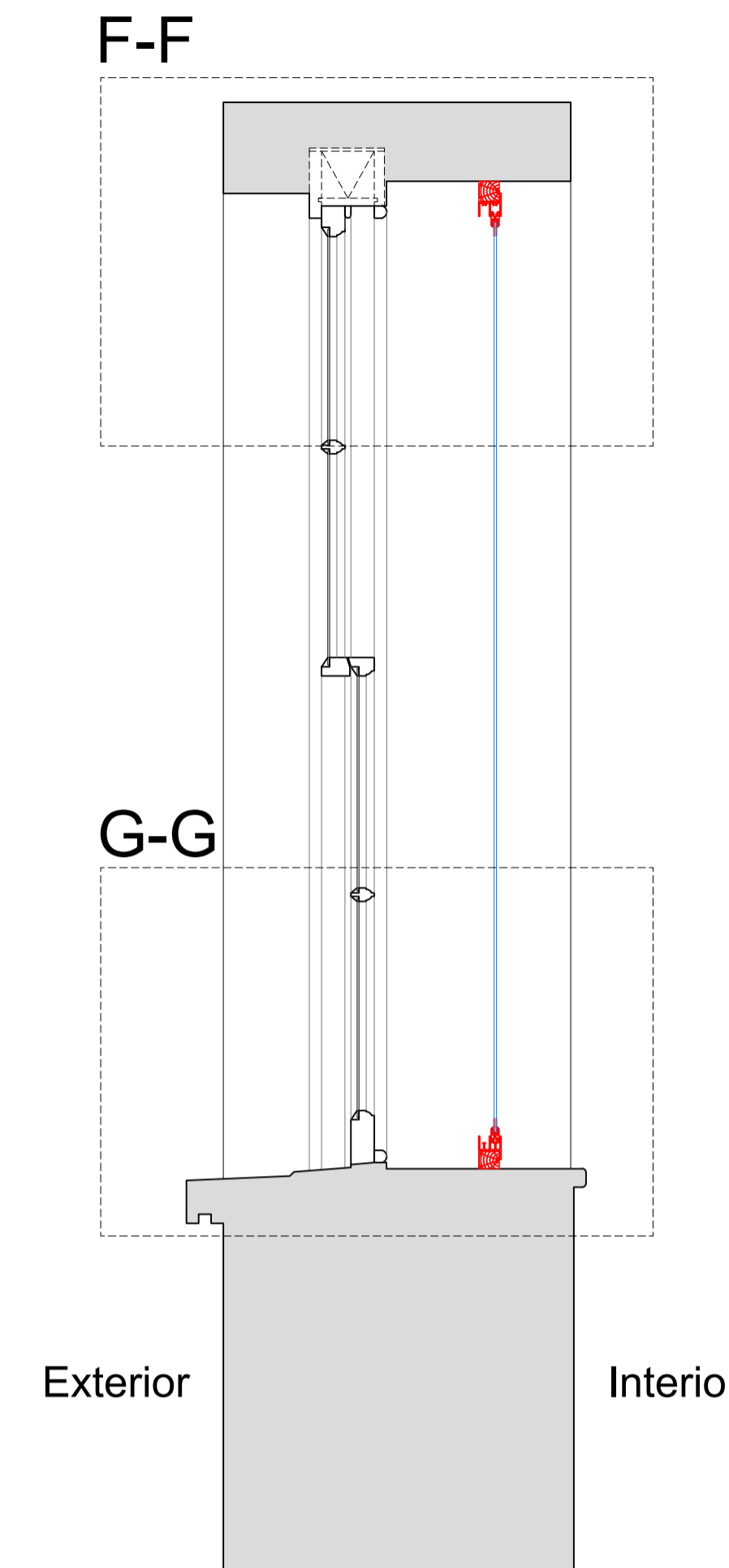

Section H-H through External Wall with Mechanical Ventilation Installed

Scale: 1:10

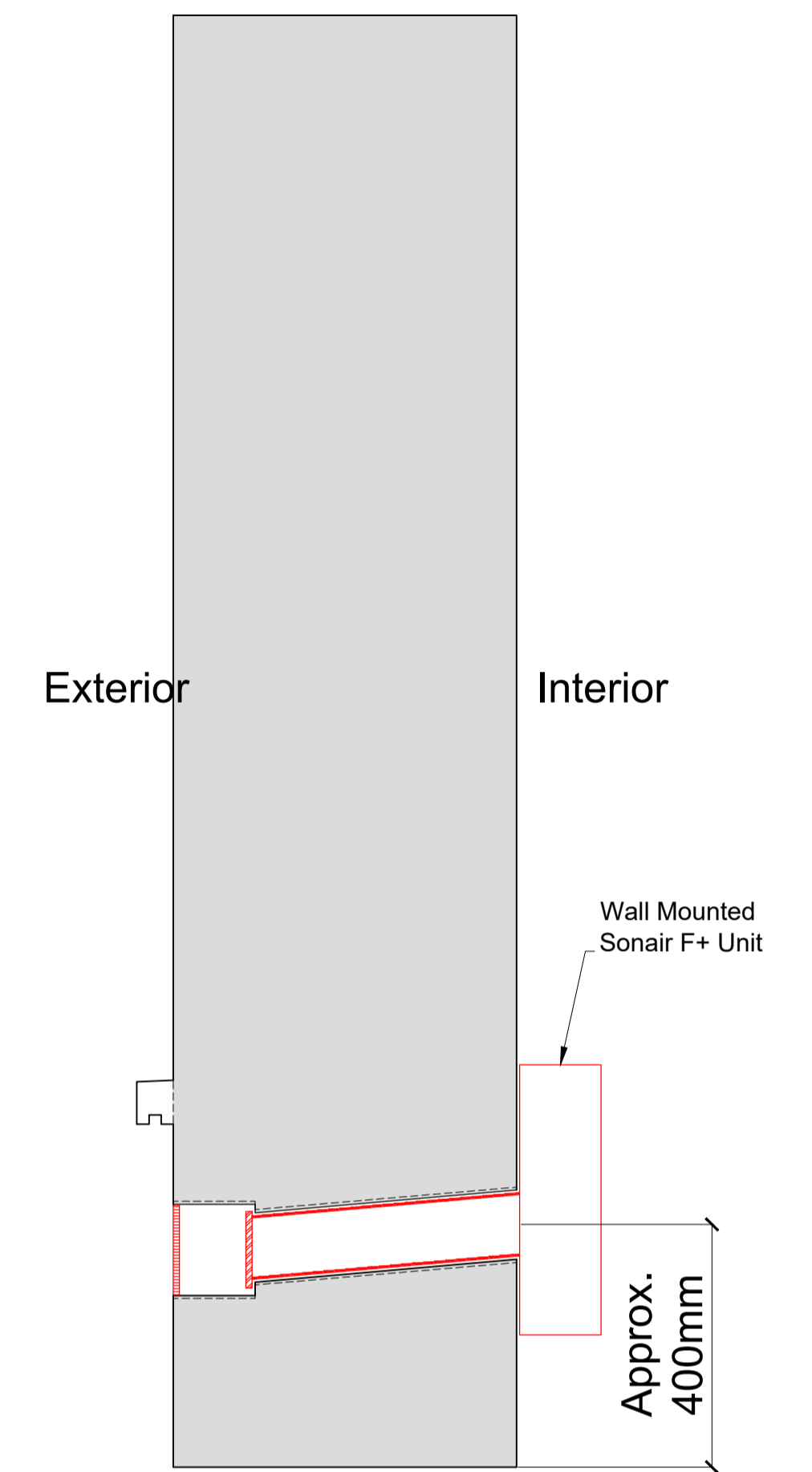

Plan Section B-B with Secondary Glazing Installed

Scale: 1:10

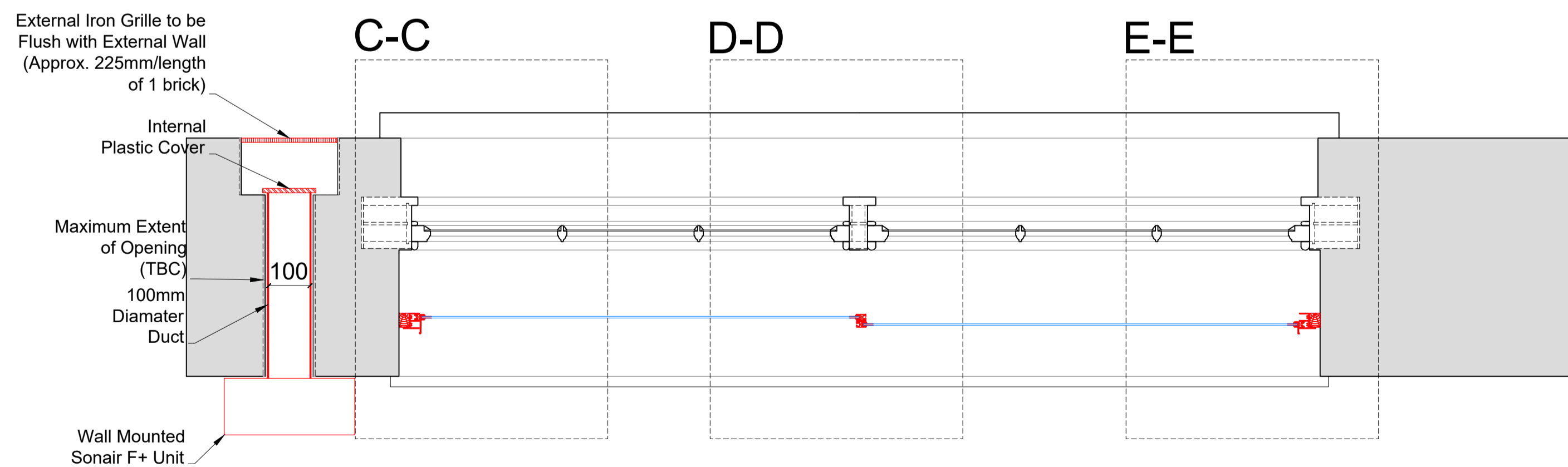

Detail of Sonair Unit

Scale: 1:5

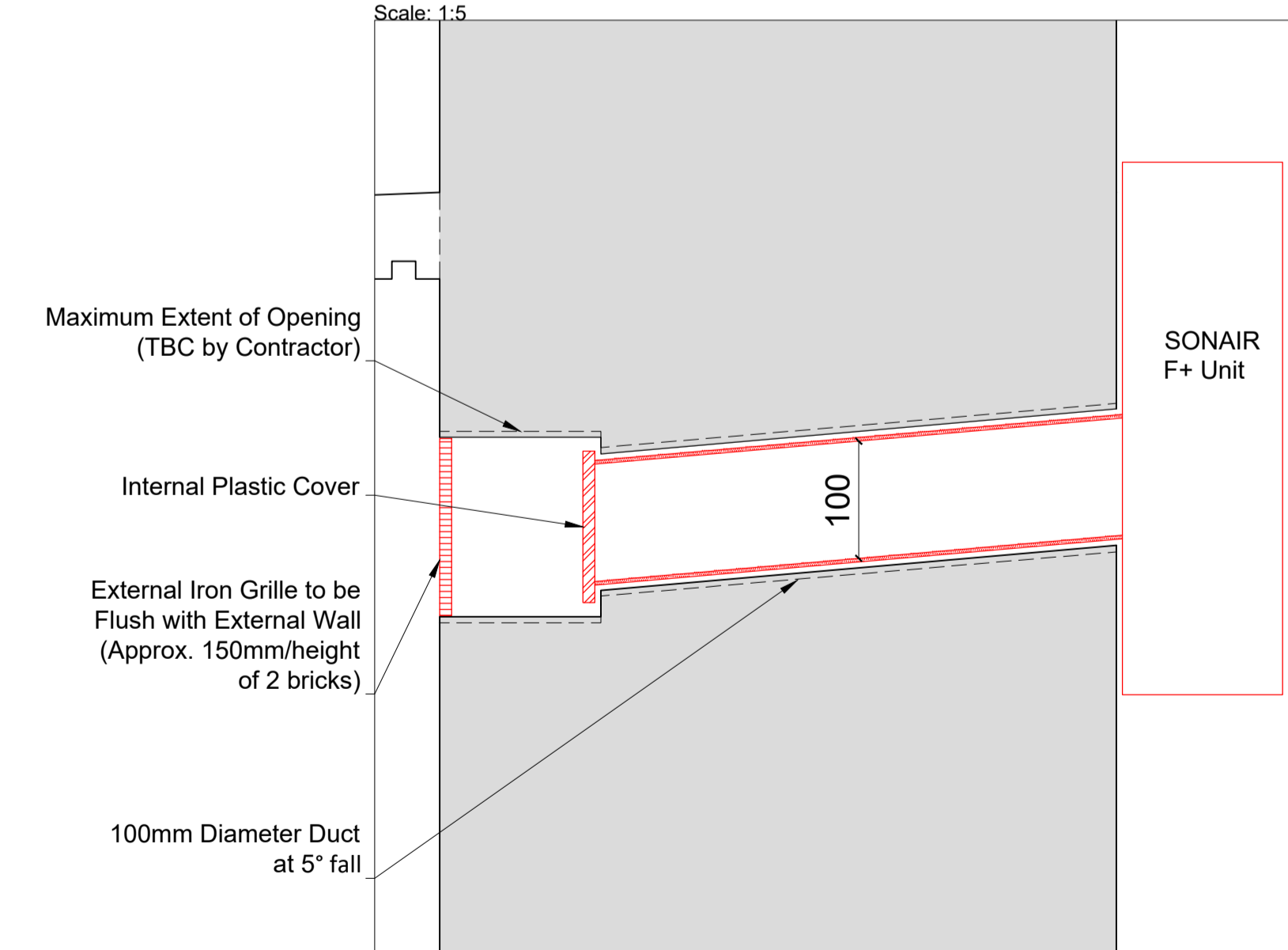

SECONDARY GLAZING SHOWN IN RED FOR VISUAL CLARITY ONLY

Revision	Date	Amendment
1.0	25-01-2021	Issued for listed building consent application

Do not reproduce this drawing without written permission  
All dimensions are in millimetres unless stated otherwise

**HS2**

High Speed (HS2) Limited  
1st-3rd Floor  
The Podium  
1 Eversholt Street  
London NW1 2DN

**COSTAIN SKANSKA**

Costain Skanska Joint Venture  
9th Floor  
The Tower  
1 Eversholt Street  
London NW1 2DN

Site Address:  
47 Morningside Terrace, London NW1

Drawing Title:  
Basement - Lounge: PROPOSED Secondary Glazing Details -  
Sheet 2 of 3

Drawn by: AP & PB  
Checked by: AP & PB  
OB  
Presentation Scale: as shown @ A1

Date: 29-04-2019  
Drawing No: WPI P066 NI - 47 MT-PR-BS-J-01.1  
Revision: 1.0

Drawing Not For Construction

Section C-C  
Scale: 1:5 on A1

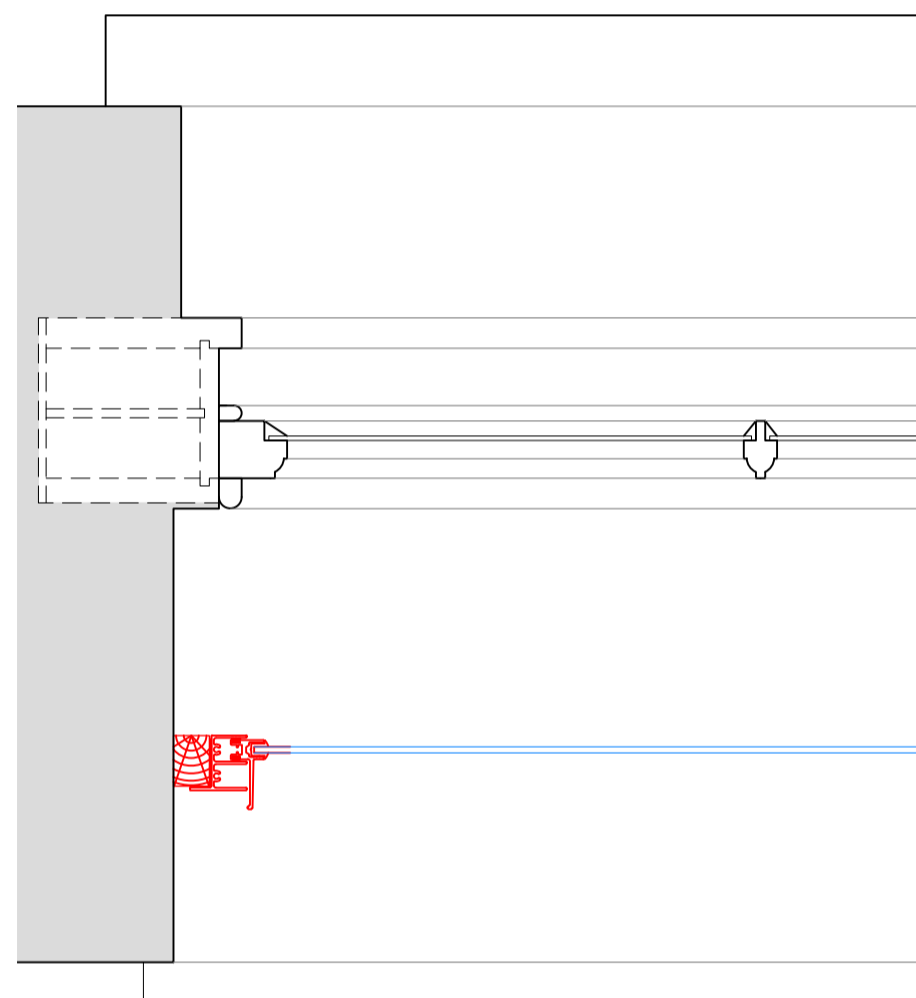

Section D-D  
Scale: 1:5 on A1

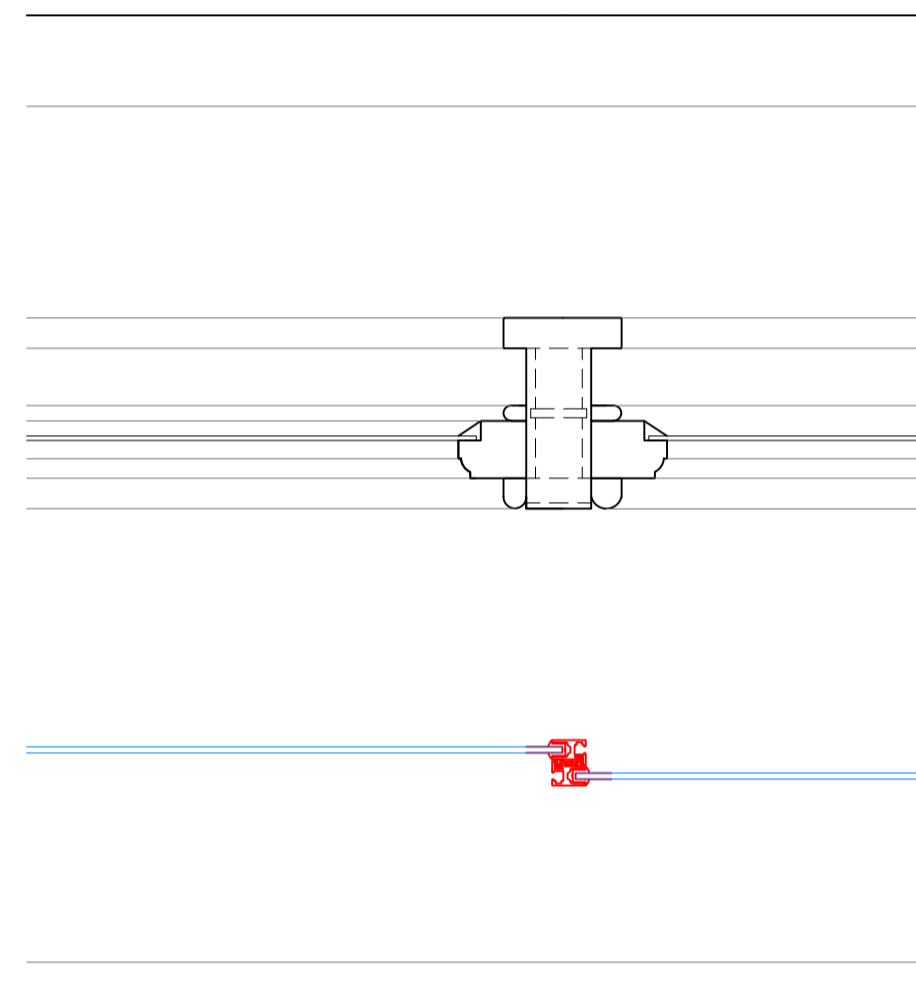

Section E-E  
Scale: 1:5 on A1

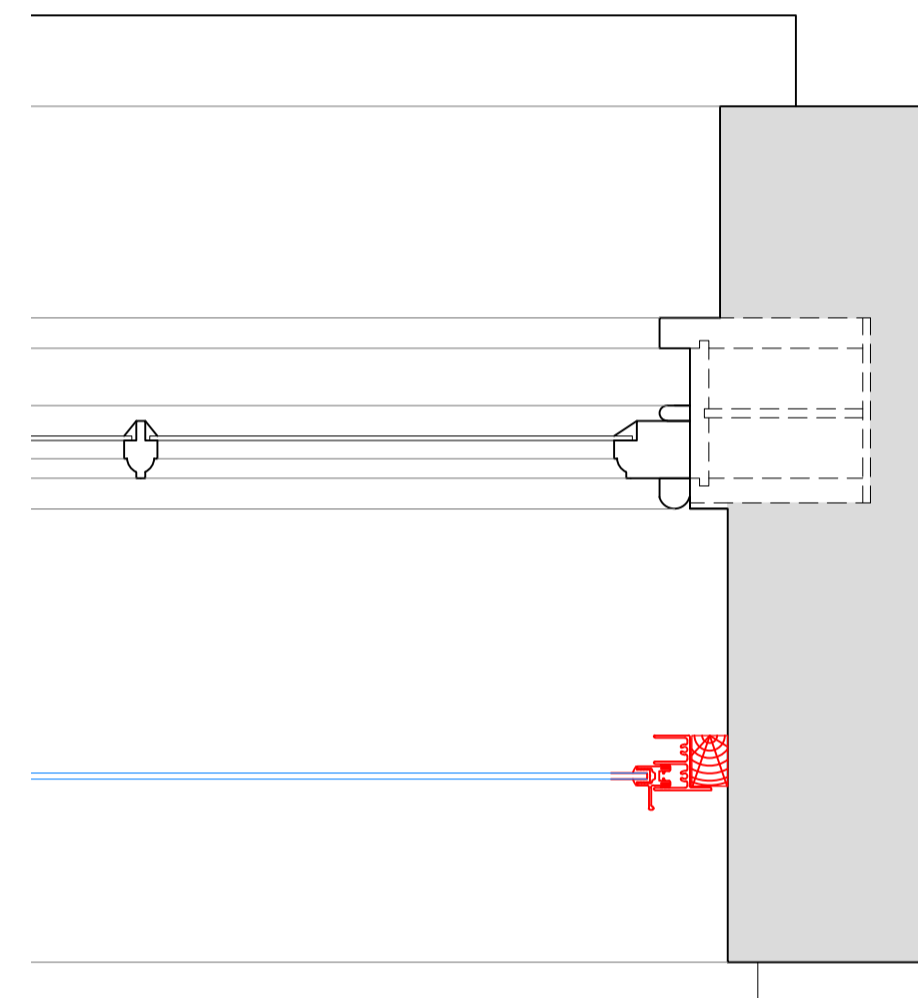

Section F-F  
Scale: 1:5 on A1

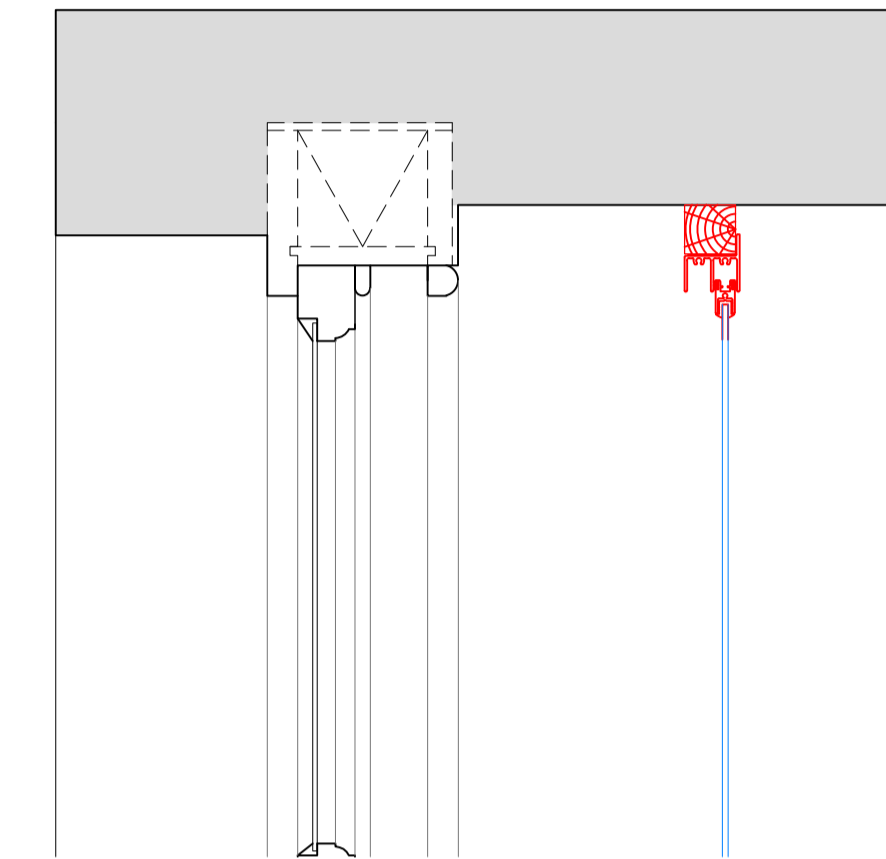

Section G-G  
Scale: 1:5 on A1

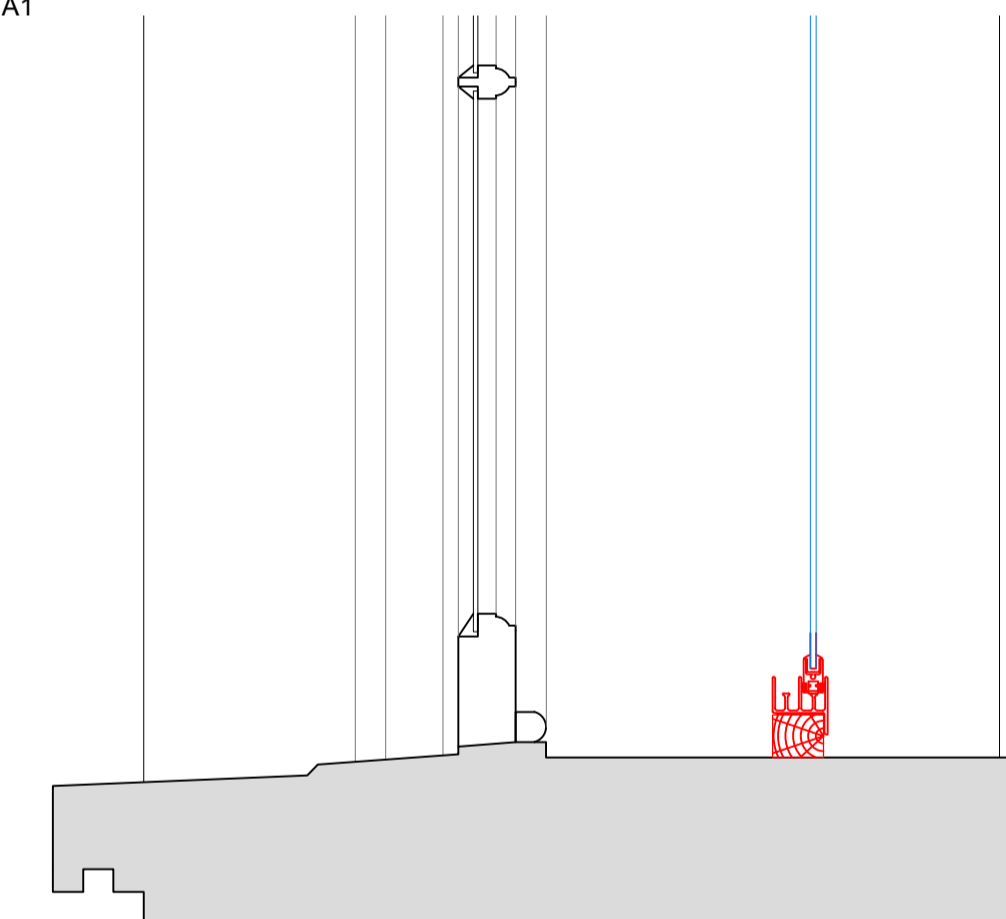

SECONDARY GLAZING SHOWN IN RED FOR VISUAL CLARITY ONLY

Revision	Date	Assessment
1.0	25-01-2021	Issued for listed building consent application

Do not reproduce this drawing without written permission  
All dimensions are in millimetres unless stated otherwise

Drawing Not For Construction

**HS2**

High Speed (HS2) Limited  
1st-3rd Floor  
The Podium  
1 Eversholt Street  
London NW1 2DN

**COSTAIN SKANSKA**

Costain Skanska Joint Venture  
9th Floor  
The Tower  
1 Eversholt Street  
London NW1 2DN

Site Address:  
47 Morningside Terrace, London NW1

Drawing Title:  
Basement - Lounge: PROPOSED Secondary Glazing Details -  
Sheet 3 of 3

Drawn by: AP & PB  
Checked by: AP & PB  
Presentation Scale: 1:5 @ A1

Date: 29-04-2019  
Drawing No: WPI P066 NI - 47 MT-PR-BS-J-01.2  
Revision: 1.0

Internal Room Elevation

Scale: 1:10

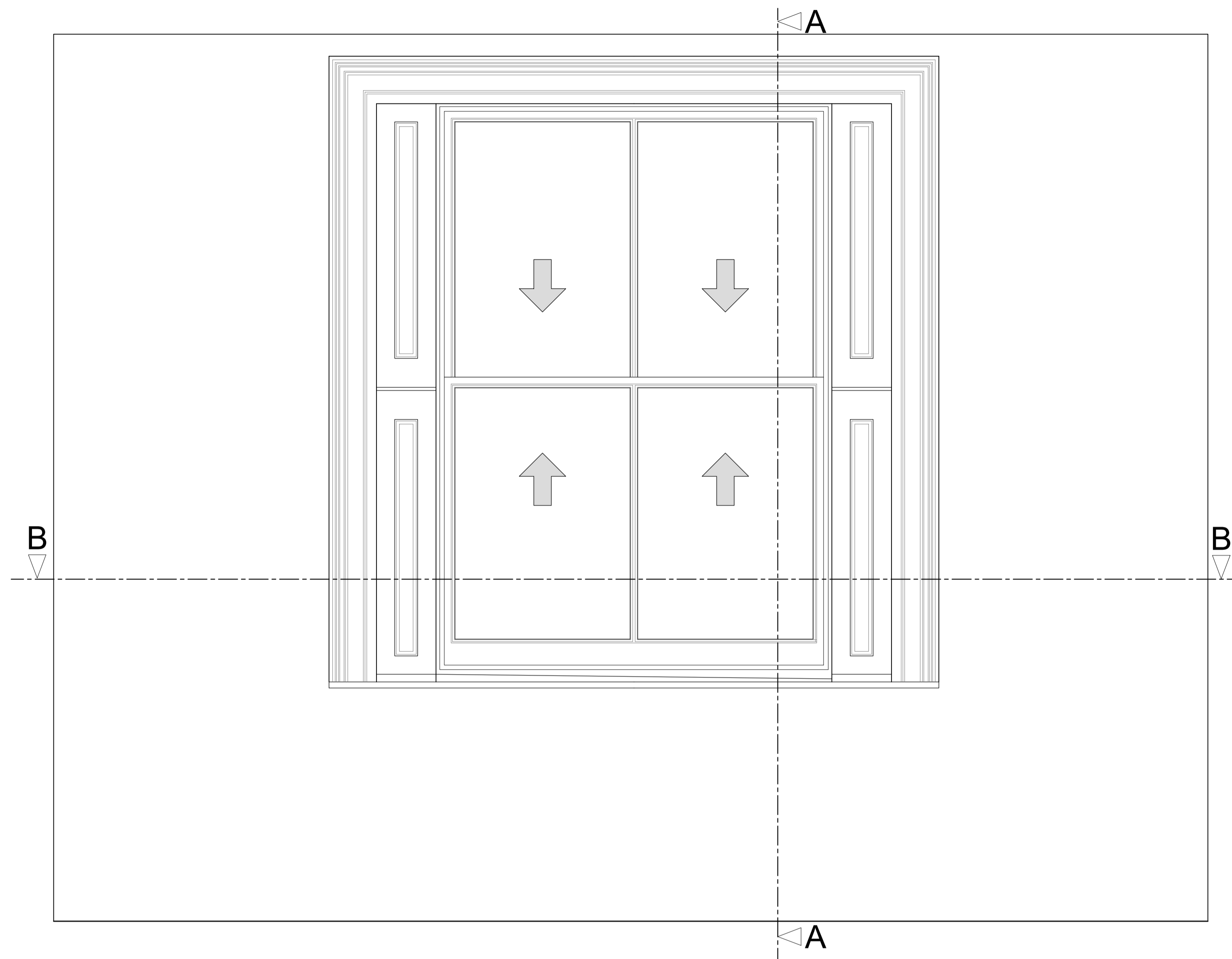

Section A-A through External Wall

Scale: 1:10

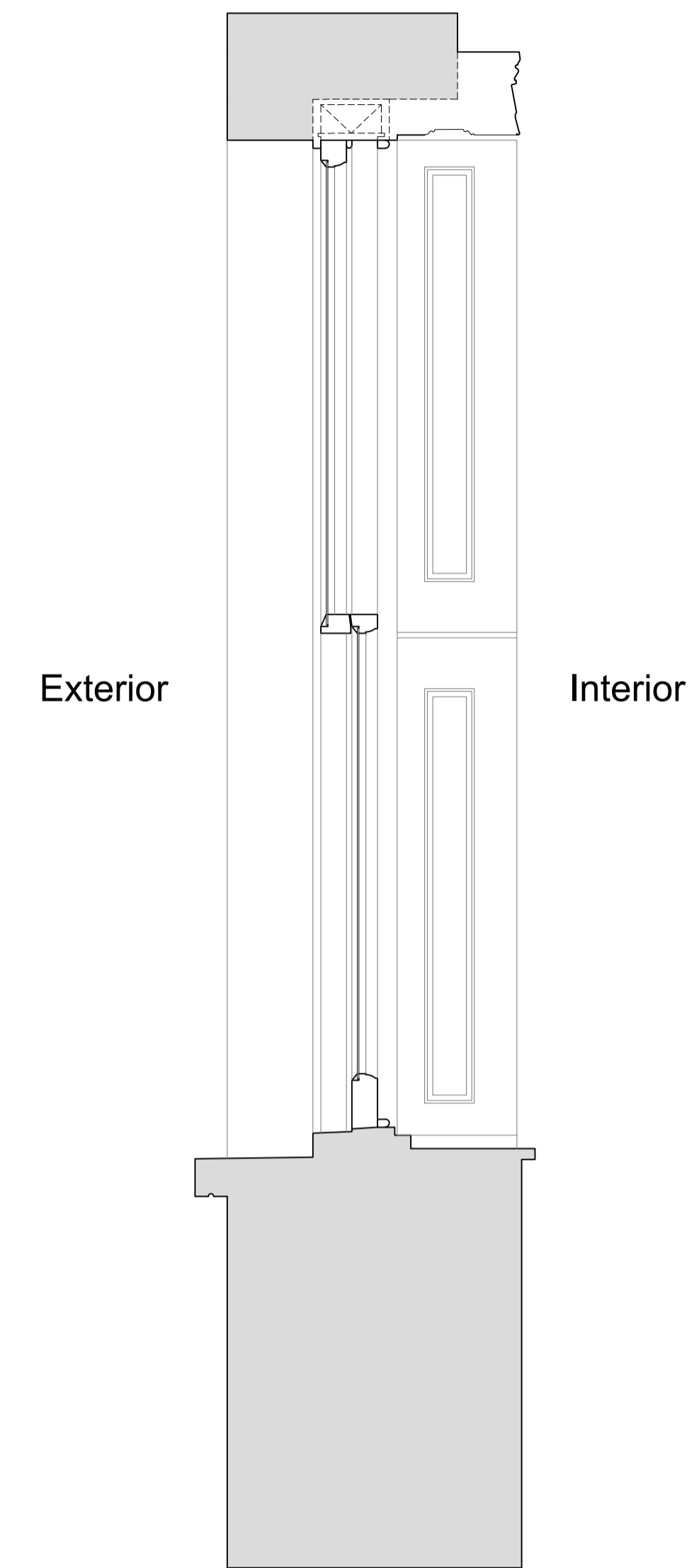

Plan Section B-B

Scale: 1:10

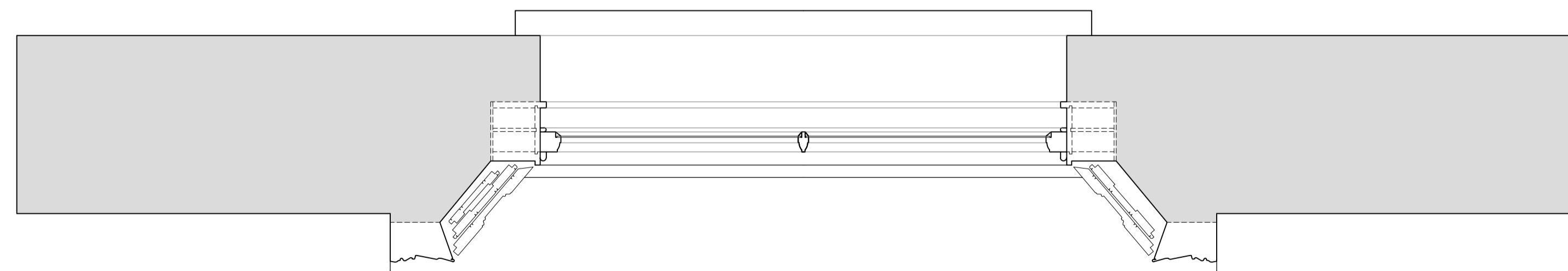

Revision	Date	Assessment
1.0	25-01-2021	Issued for listed building consent application

Do not reproduce this drawing without written permission  
All dimensions are in millimetres unless stated otherwise

Drawing Not For Construction

**HS2**

High Speed (HS2) Limited  
1st-3rd Floor  
The Tower  
1 Eversholt Street  
London NW1 2DN

**COSTAIN SKANSKA**

Costain Skanska Joint Venture  
9th Floor  
The Tower  
1 Eversholt Street  
London NW1 2DN

Site Address: 47 Mornington Terrace, London NW1			
Drawing Title: Ground Floor - Lounge: EXISTING Window Joinery Details - Sheet 1 of 3			
Drawn by: AP & PB	Checked by: AP & PB	OB	Presentation Scale: as shown @ A1
Date: 29-04-2019	Drawing No: WPI P066 NI - 47 MT-EX-GF-J-02	Revision: 1.0	

Internal Room Elevation with Secondary Glazing Installed

Scale: 1:10

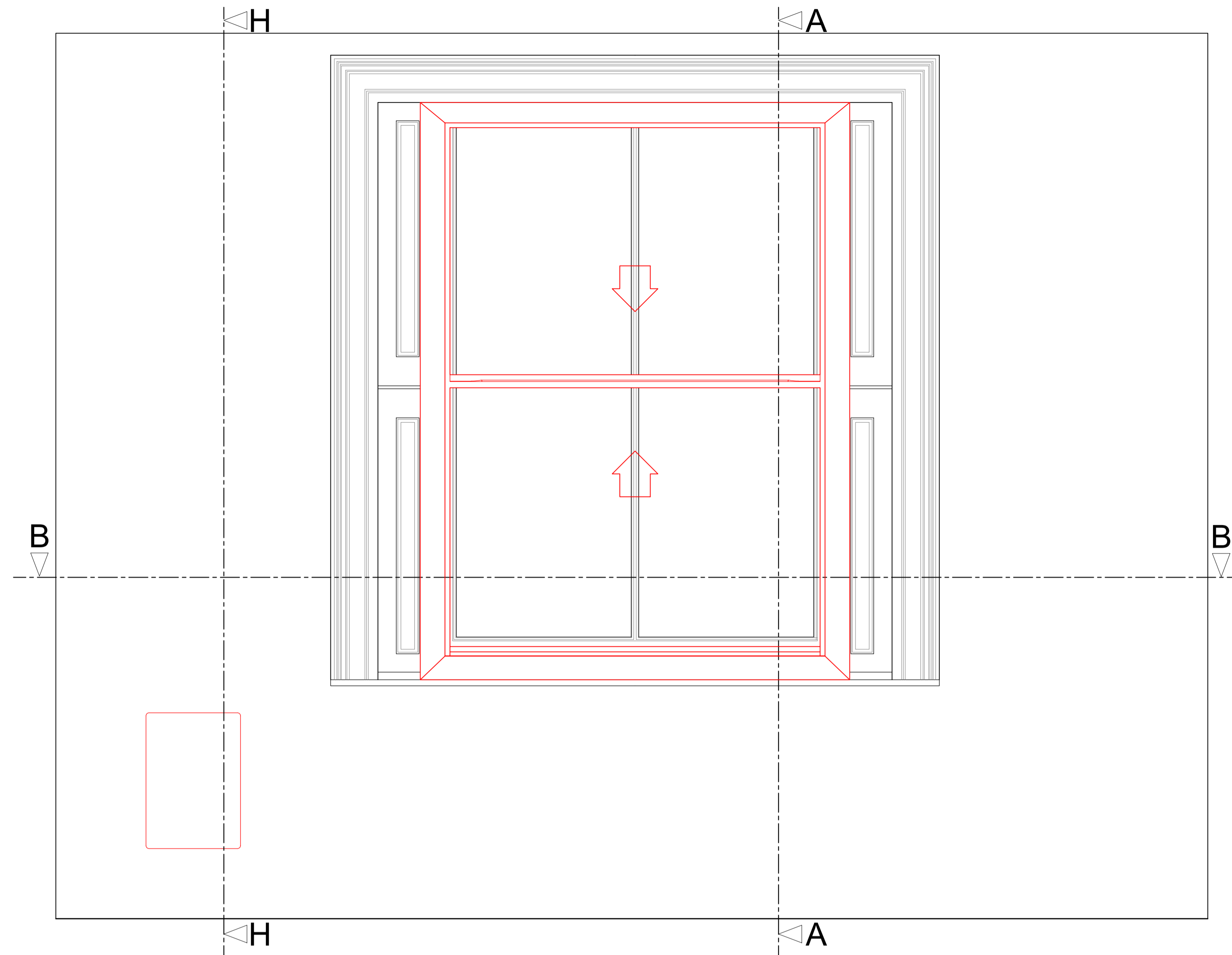

Section A-A through External Wall with Secondary Glazing Installed

Scale: 1:10

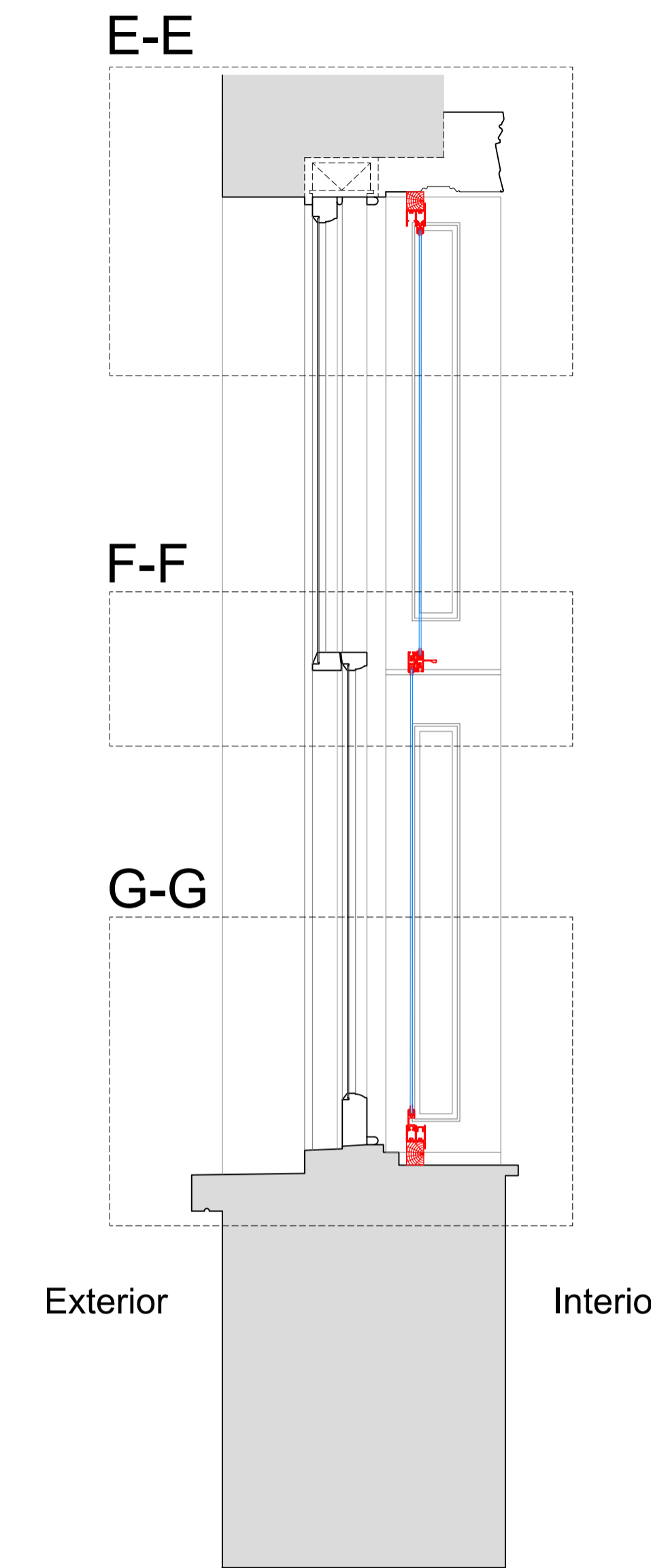

Section H-H through External Wall with Mechanical Ventilation Installed

Scale: 1:10

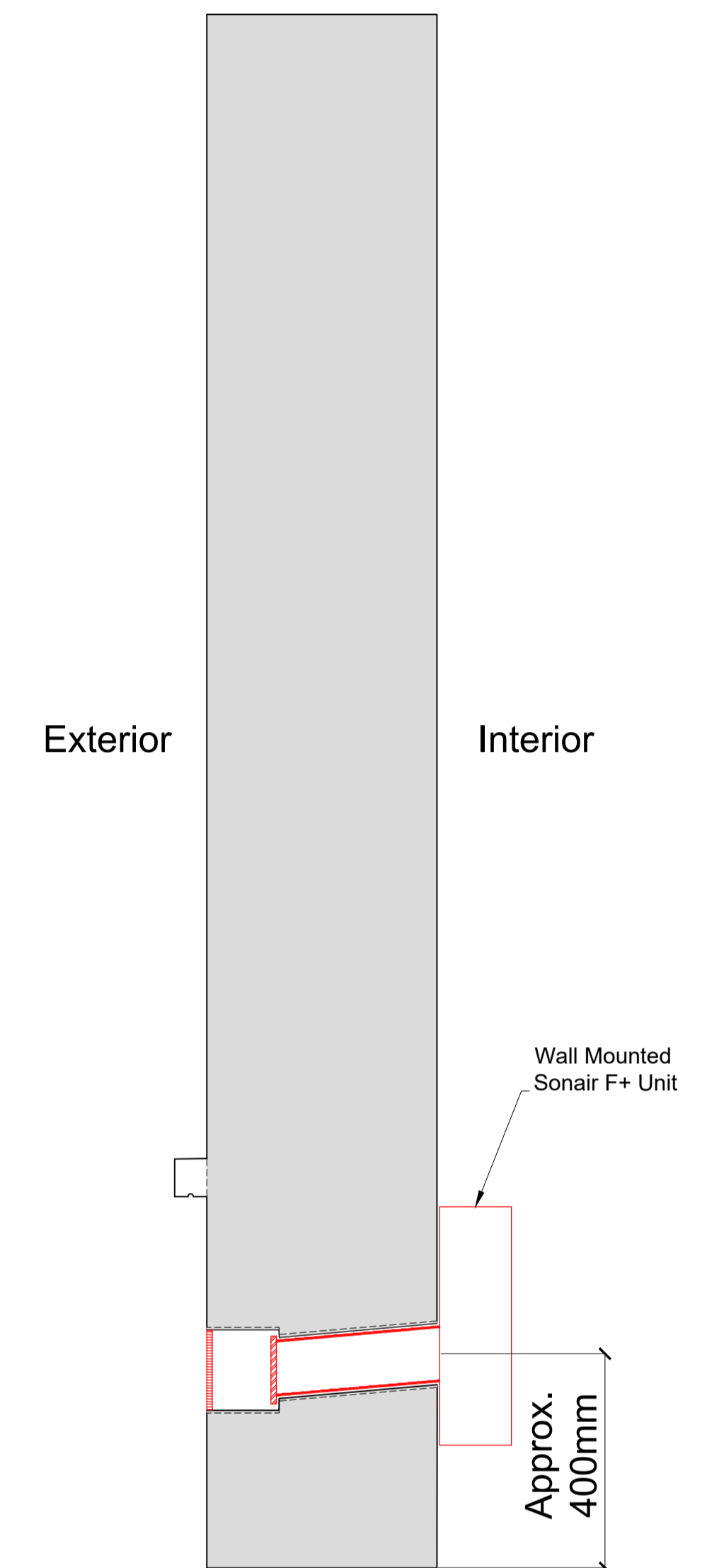

Plan Section B-B with Secondary Glazing Installed

Scale: 1:10

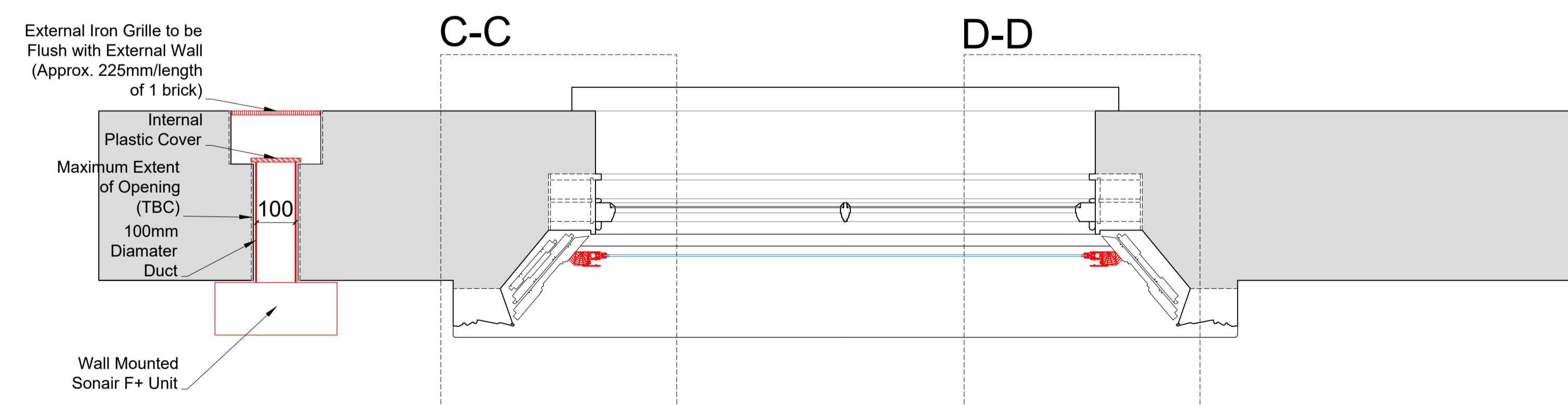

Detail of Sonair Unit

Scale: 1:5

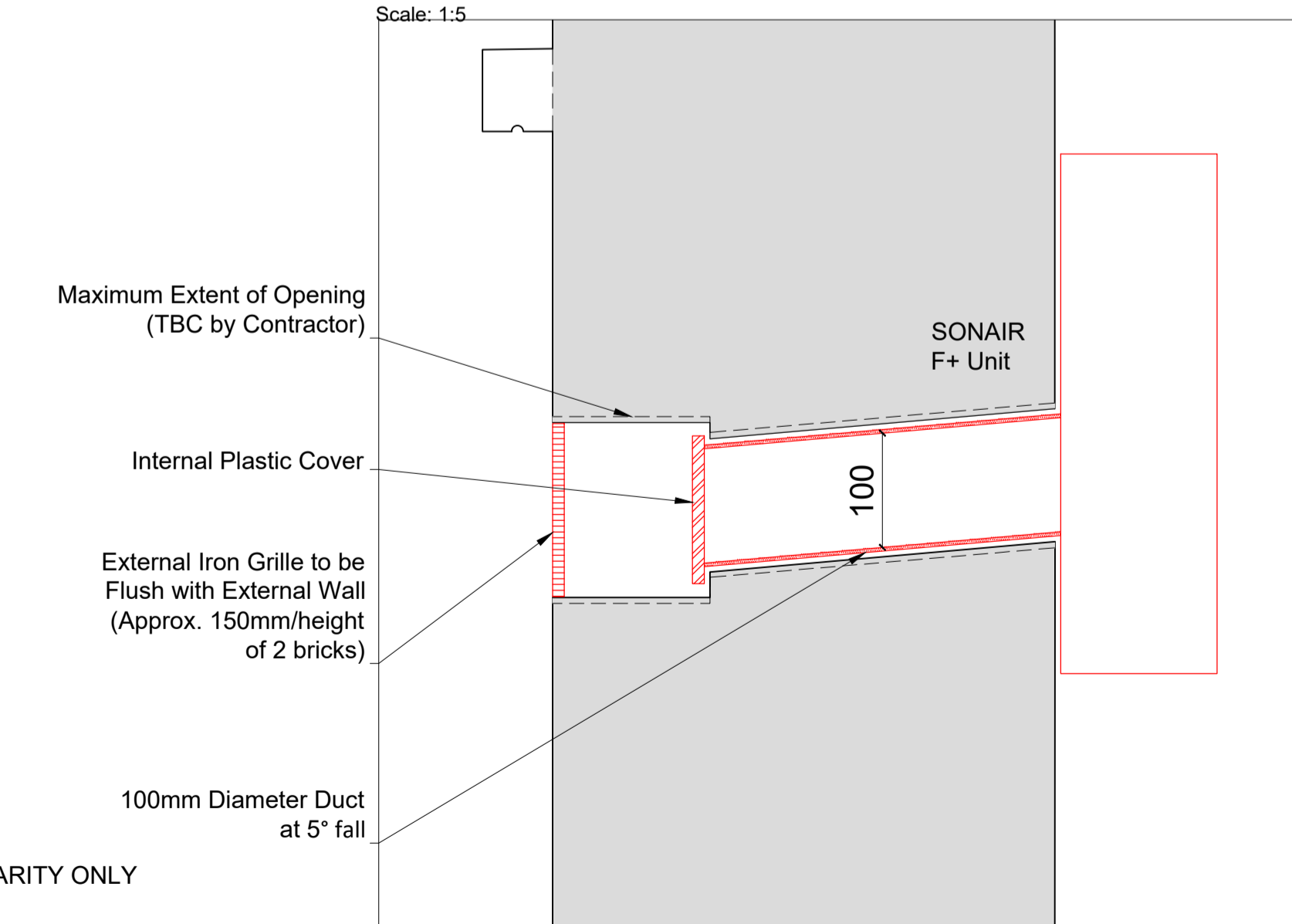

SECONDARY GLAZING SHOWN IN RED FOR VISUAL CLARITY ONLY

Revision	Date	Amendment
1.0	25-01-2021	Issued for listed building consent application

Do not reproduce this drawing without written permission  
All dimensions are in millimetres unless stated otherwise

**HS2**

High Speed (HS2) Limited  
1st-3rd Floor  
The Podium  
1 Eversholt Street  
London NW1 2DN

**COSTAIN SKANSKA**

Costain Skanska Joint Venture  
9th Floor  
The Tower  
1 Eversholt Street  
London NW1 2DN

Site Address:  
47 Mornington Terrace, London NW1

Drawing Title:  
Ground Floor - Lounge: PROPOSED Secondary Glazing Details -  
Sheet 2 of 3

Drawn by: AP & PB  
Checked by: AP & PB  
OB  
Presentation Scale: as shown @ A1

Date: 29-04-2019  
Drawing No: WPI P066 NI - 47 MT-PR-GF-J-02.1  
Revision: 1.0

Drawing Not For Construction

Section C-C  
Scale: 1:5 on A1

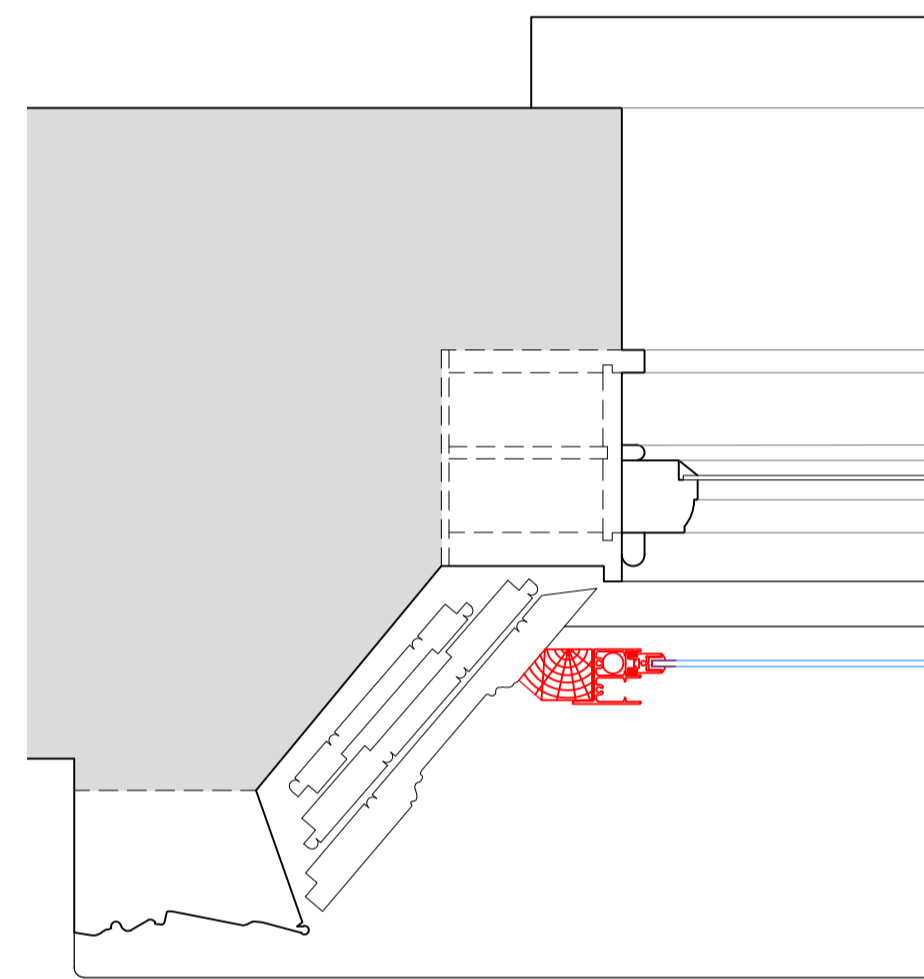

Section D-D  
Scale: 1:5 on A1

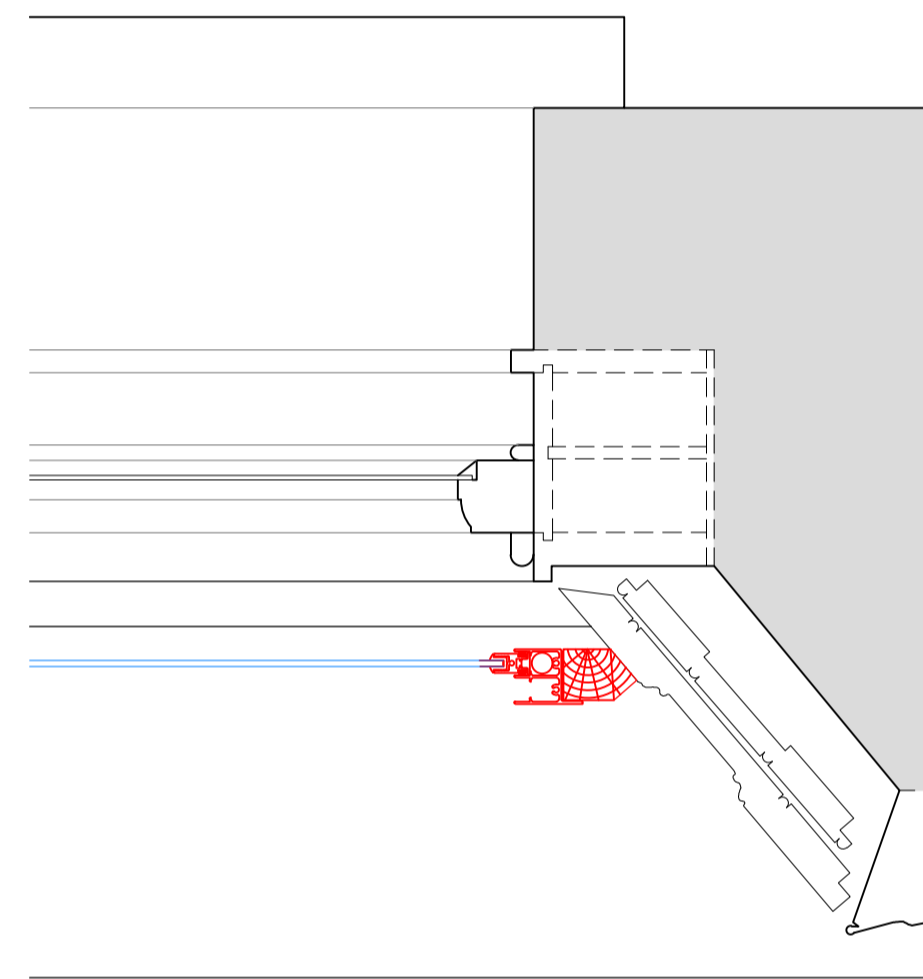

Section E-E  
Scale: 1:5 on A1

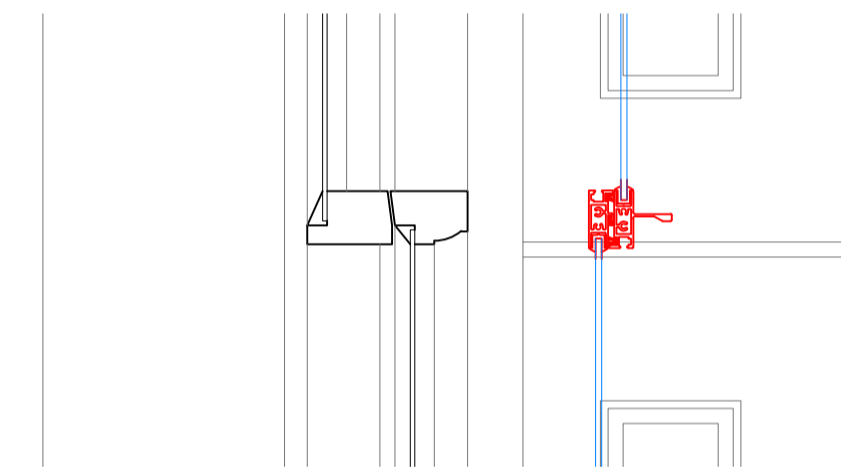
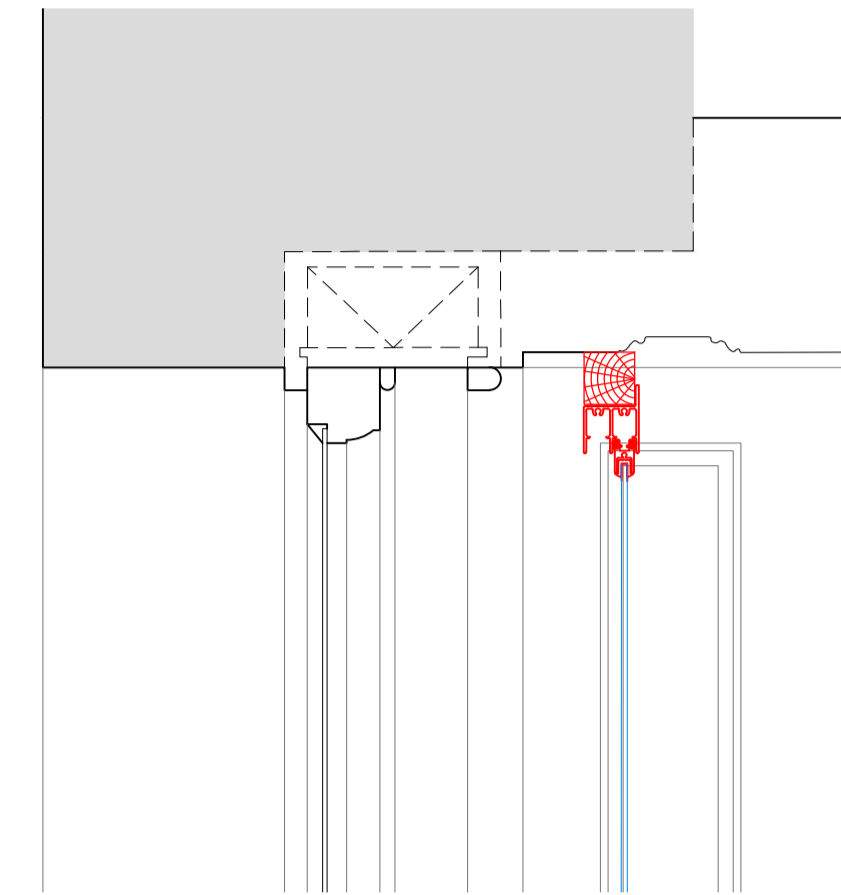

Section F-F  
Scale: 1:5 on A1

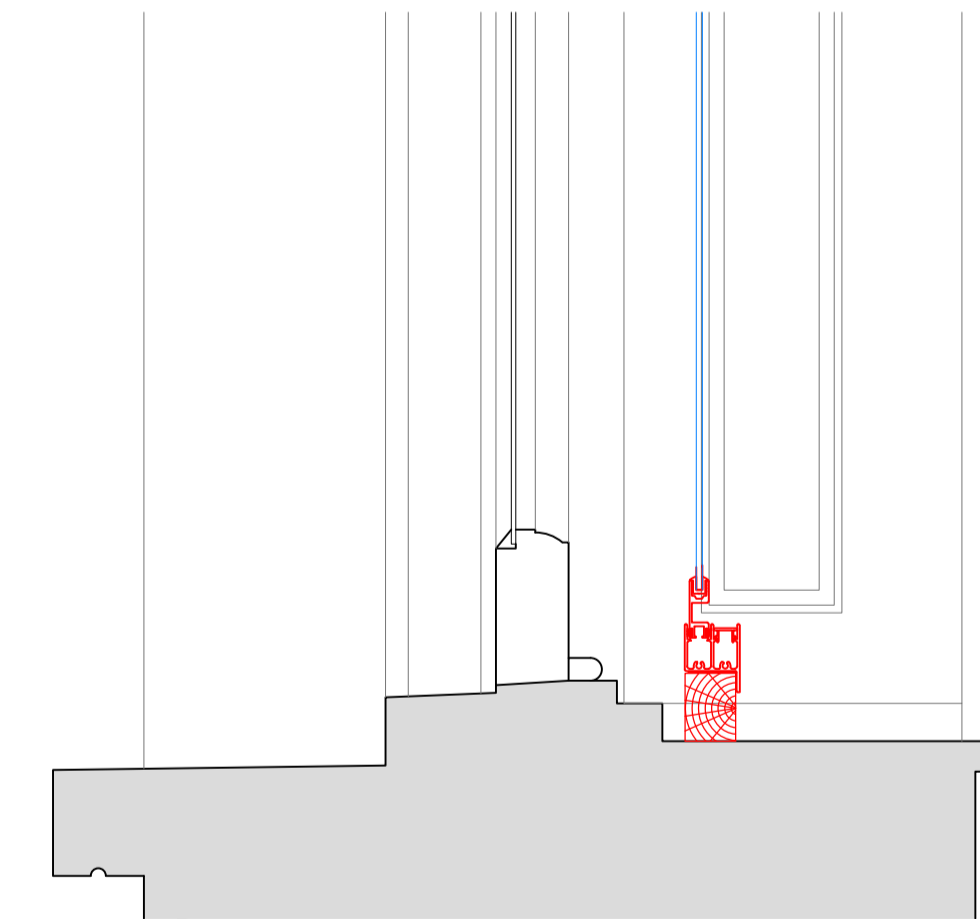

SECONDARY GLAZING SHOWN IN RED FOR VISUAL CLARITY ONLY

Revision	Date	Assessment
1.0	25-01-2021	Issued for listed building consent application

Do not reproduce this drawing without written permission  
All dimensions are in millimetres unless stated otherwise

Drawing Not For Construction

**HS2**

High Speed (HS2) Limited  
1st-3rd Floor  
The Podium  
1 Eversholt Street  
London NW1 2DN

**COSTAIN SKANSKA**

Costain Skanska Joint Venture  
9th Floor  
The Tower  
1 Eversholt Street  
London NW1 2DN

Site Address: 47 Morningside Terrace, London NW1			
Drawing Title: Ground Floor - Lounge: PROPOSED Secondary Glazing Details - Sheet 3 of 3			
Drawn by: AP & PB	Checked by: AP & PB	Approved by: OB	Representation Scale: 1:5 @ A1
Date: 29-04-2019	Drawing No: WPI P066 NI - 47 MT-PR-GF-J-02.2	Revision: 1.0	

Internal Room Elevation  
Scale: 1:10

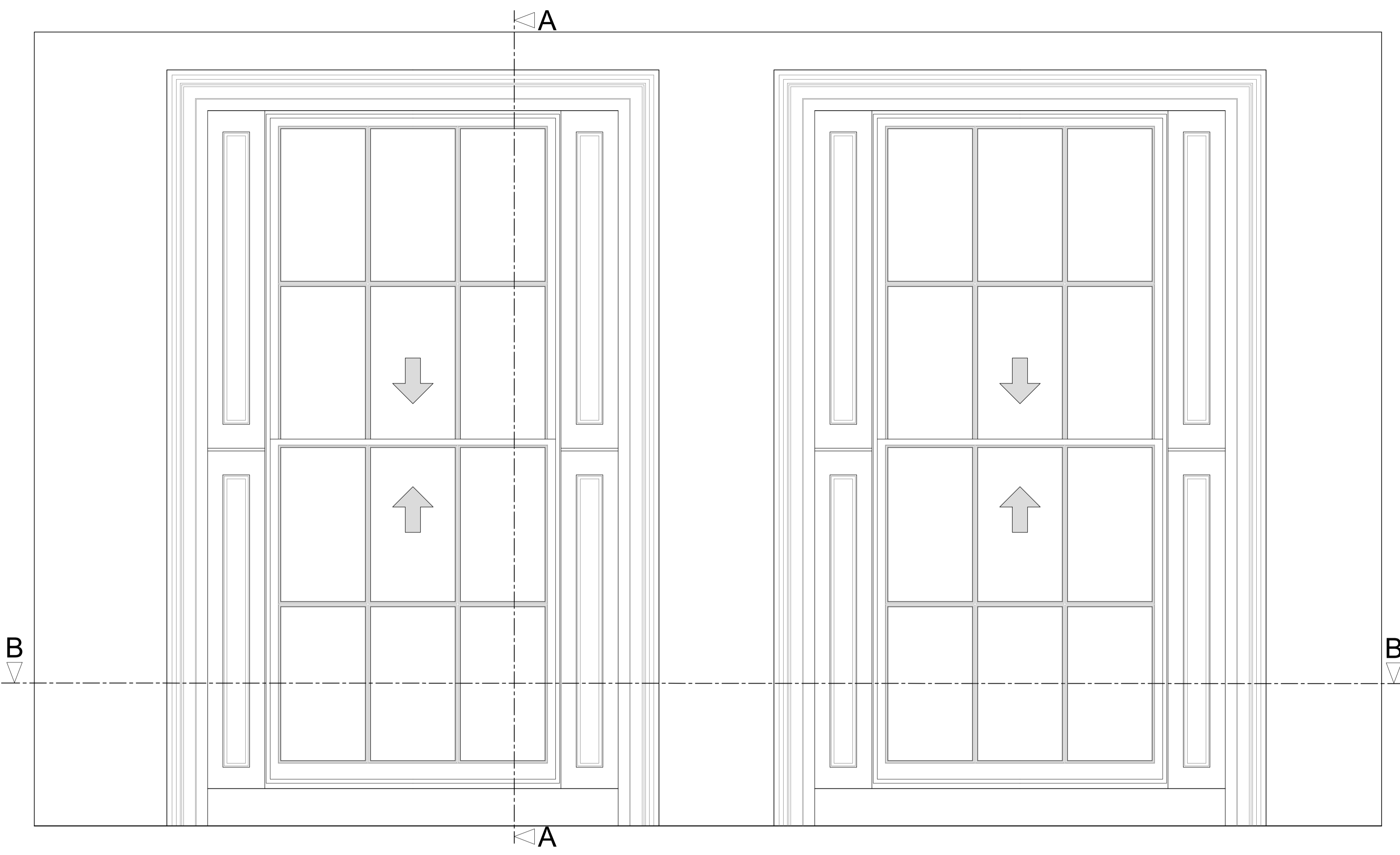

Section A-A through External Wall  
Scale: 1:10

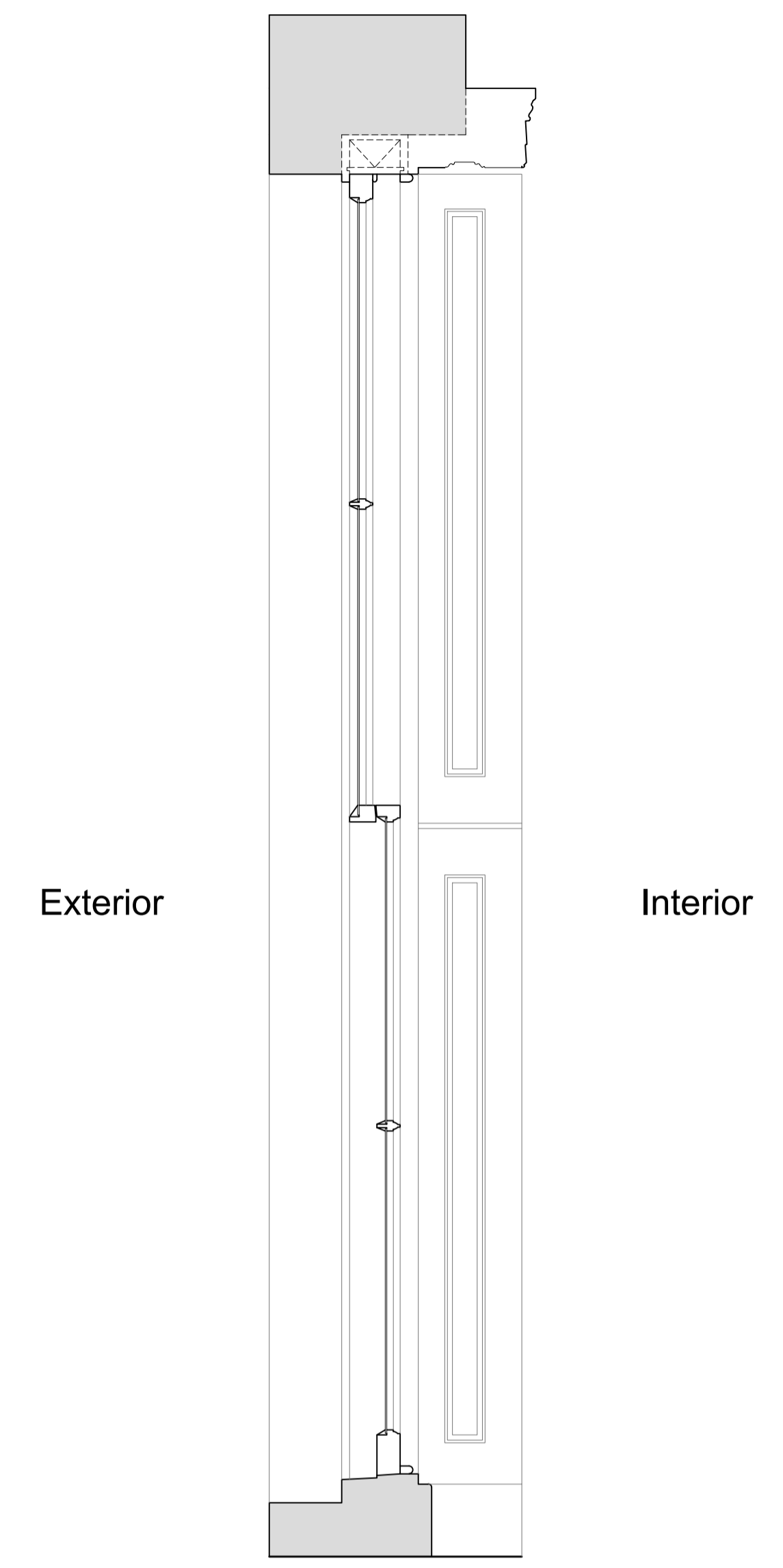

Plan Section B-B  
Scale: 1:10

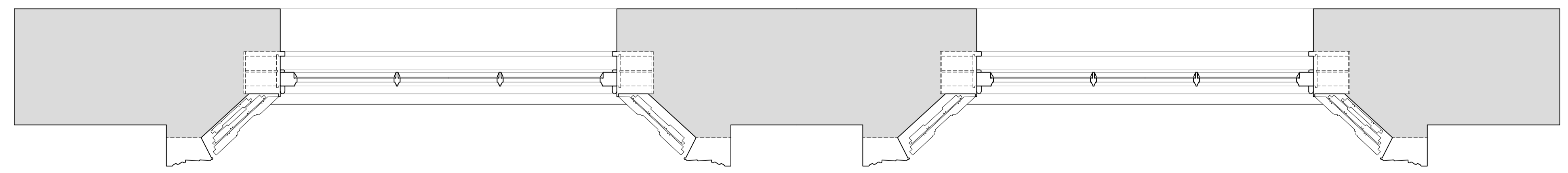

Revision	Date	Assessment
1.0	25-01-2021	Issued for listed building consent application

Do not reproduce this drawing without written permission  
All dimensions are in millimetres unless stated otherwise

**HS2**

High Speed (HS2) Limited  
1st-3rd Floor  
The Tower  
1 Eversholt Street  
London NW1 2DN

**COSTAIN SKANSKA**

Costain Skanska Joint Venture  
9th Floor  
The Tower  
1 Eversholt Street  
London NW1 2DN

Site Address: 47 Mornington Terrace, London NW1			
Drawing Title: First Floor - Lounge: EXISTING Window Joinery Details - Sheet 1 of 3			
Drawn by: AP & PB	Checked by: AP & PB	Drawn by: OB	Presentation Scale: as shown @ A1
Date: 29-04-2019	Drawing No: WPI P066 NI - 47 MT-EX-FF-J-03	Revision: 1.0	

Drawing Not For Construction

Internal Room Elevation with Secondary Glazing Installed

Scale: 1:10

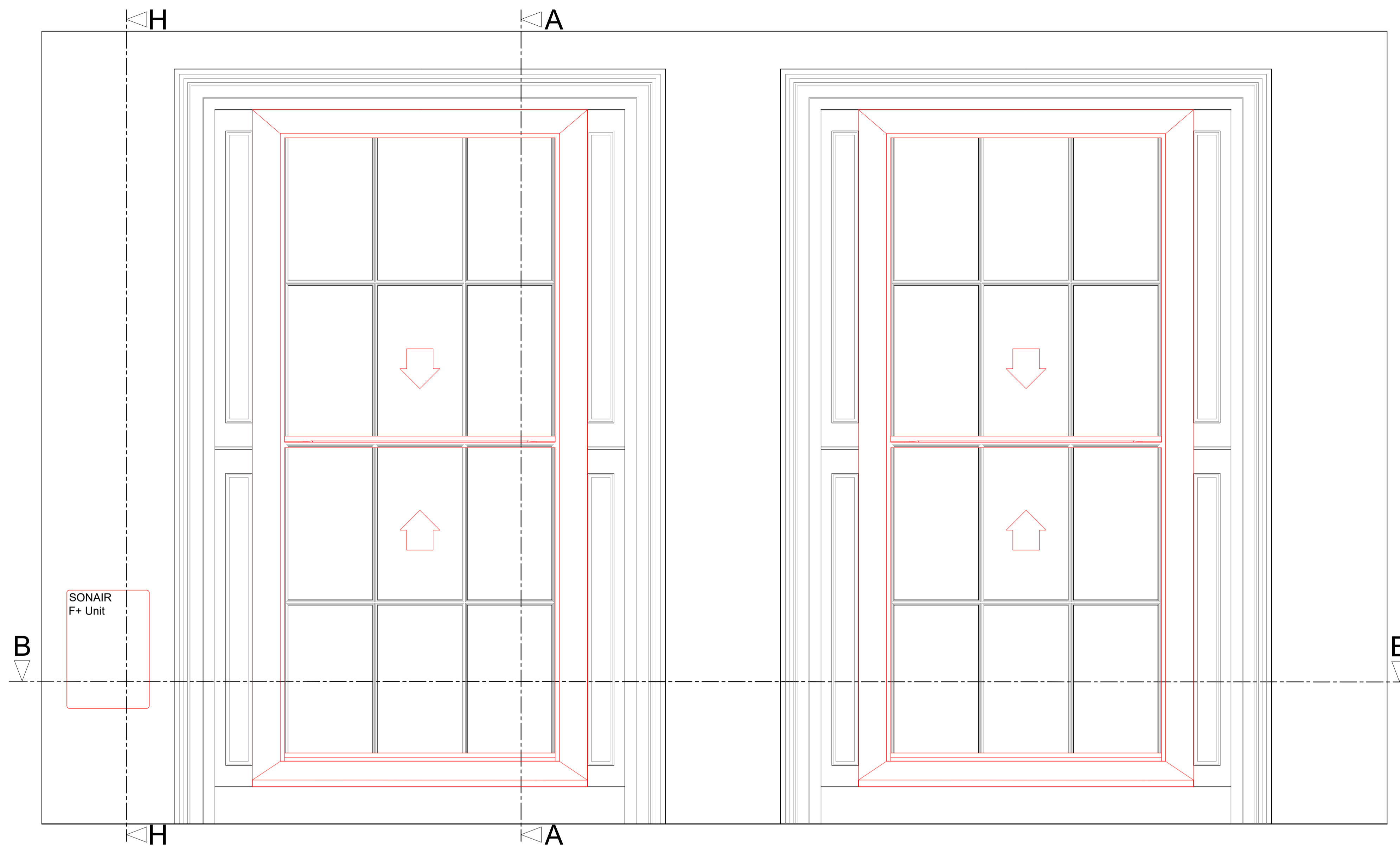

Section A-A through External Wall with Secondary Glazing Installed

Scale: 1:10

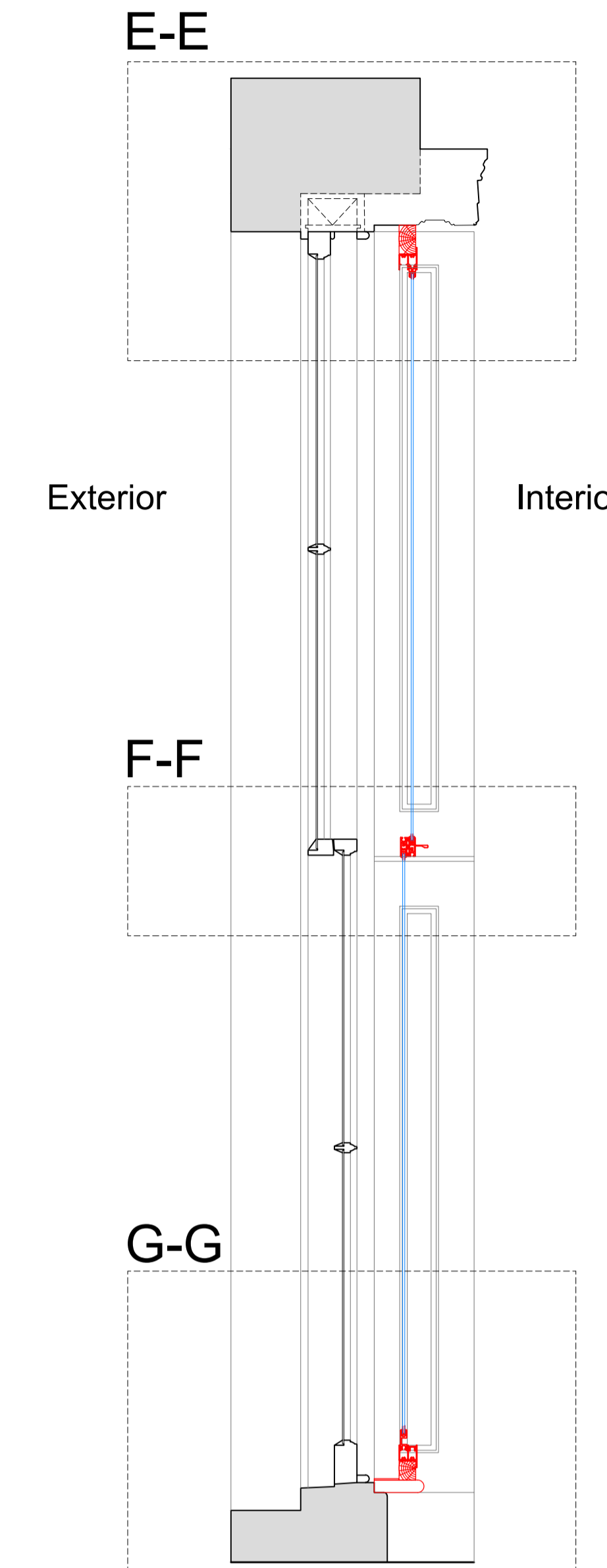

Section H-H through External Wall with Mechanical Ventilation Installed

Scale: 1:10

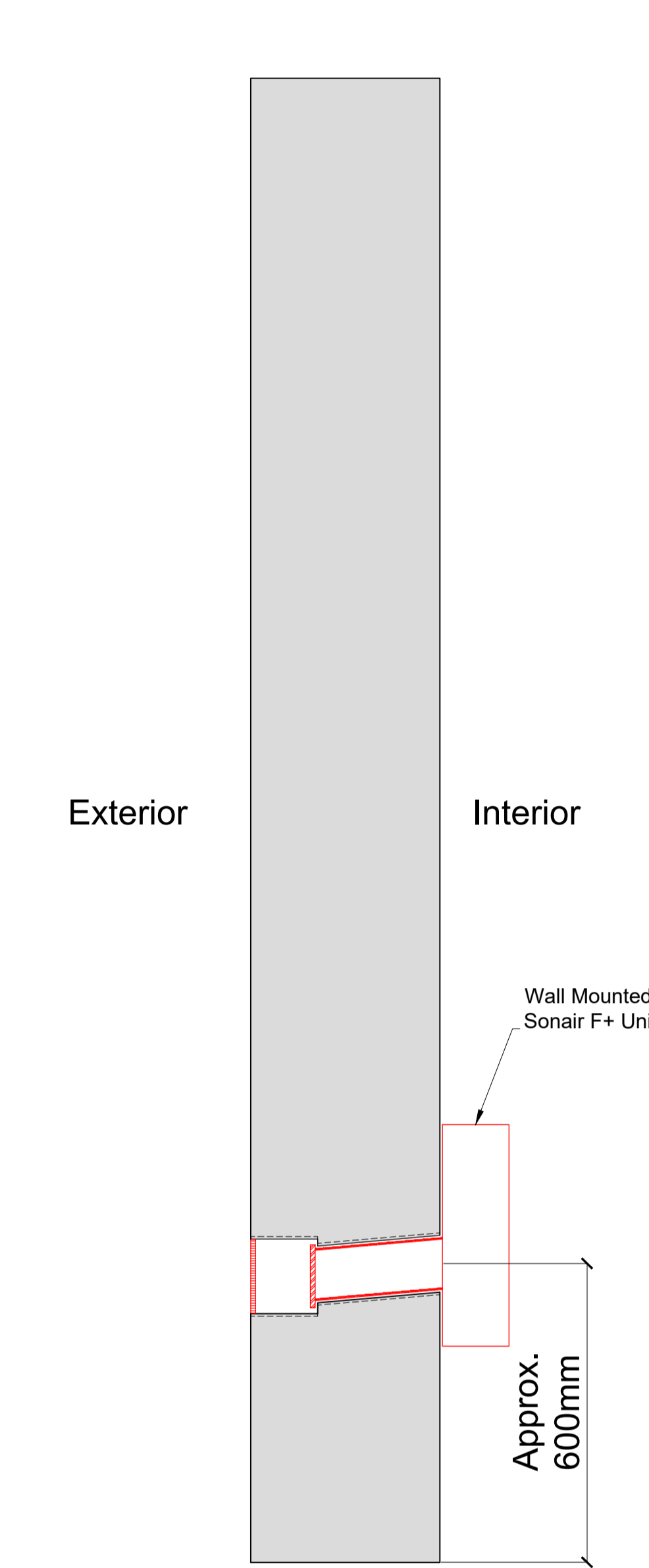

Plan Section B-B with Secondary Glazing Installed

Scale: 1:10

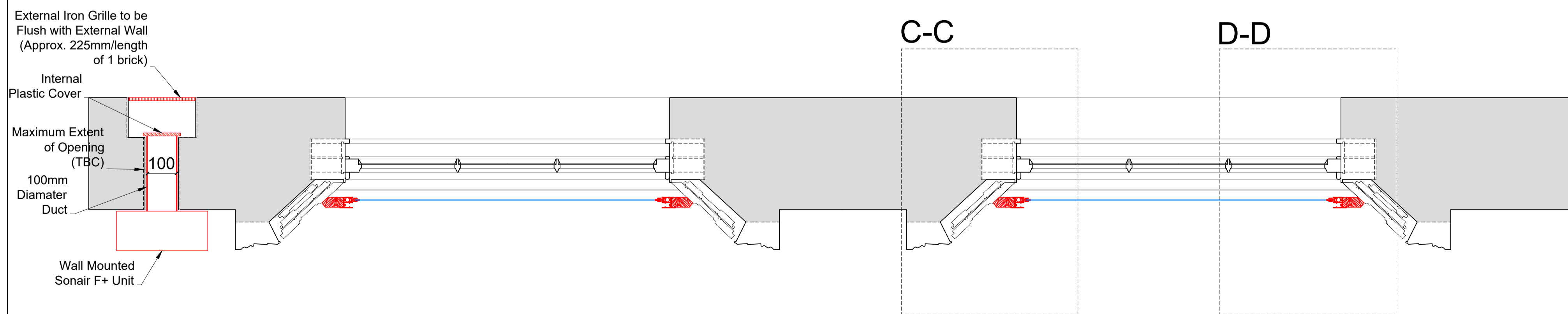

SECONDARY GLAZING SHOWN IN RED FOR VISUAL CLARITY ONLY

Detail of Sonair Unit

Scale: 1:5

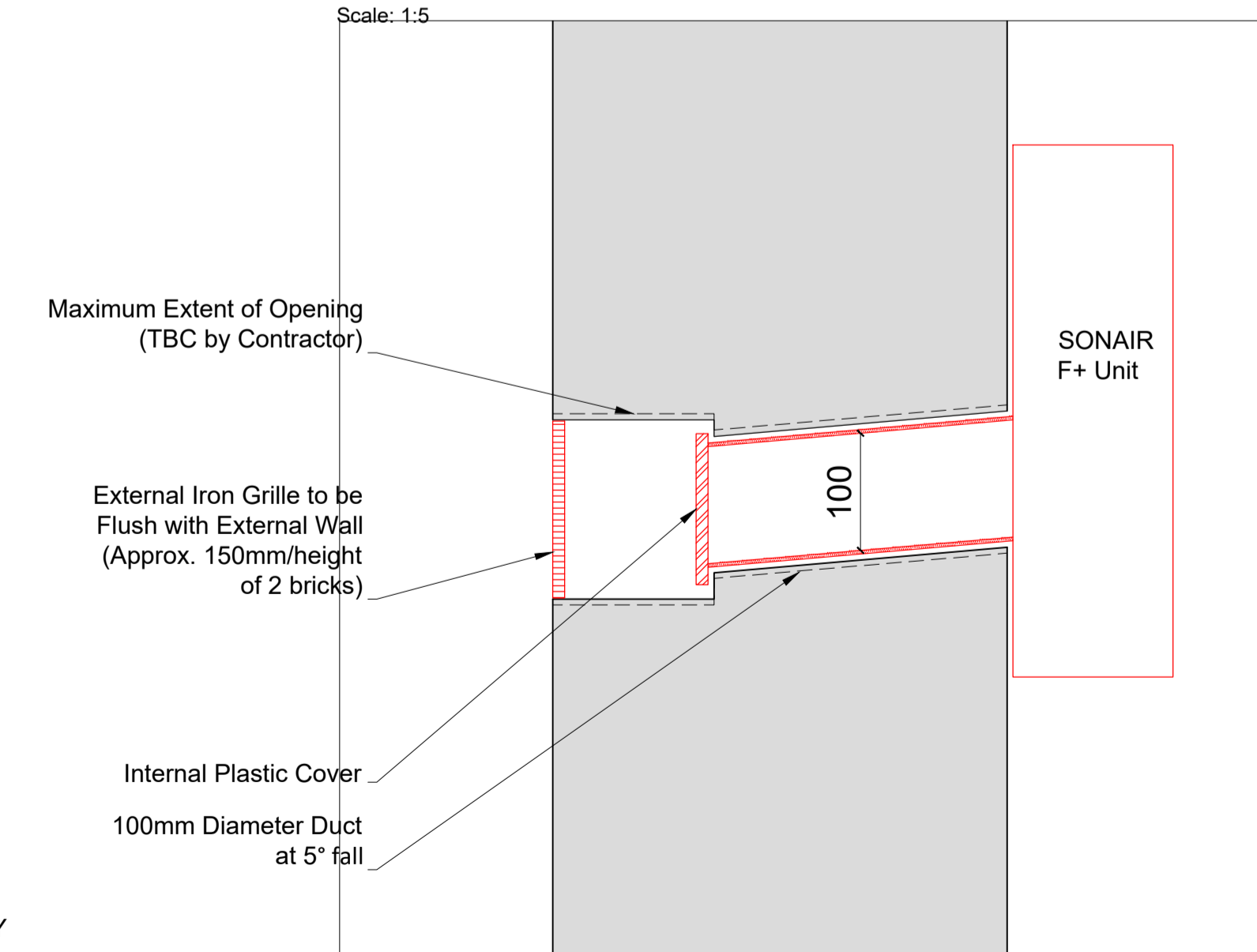

Revision	Date	Amendment
1.0	25-01-2021	Issued for listed building consent application

Do not reproduce this drawing without written permission  
All dimensions are in millimetres unless stated otherwise

**HS2**

High Speed (HS2) Limited  
1st-3rd Floor  
The Tower  
1 Eversholt Street  
London NW1 2DN

**COSTAIN SKANSKA**

Costain Skanska Joint Venture  
9th Floor  
The Tower  
1 Eversholt Street  
London NW1 2DN

Site Address: 47 Mornington Terrace, London NW1			
Drawing Title: First Floor - Lounge: PROPOSED Secondary Glazing Details - Sheet 2 of 3			
Drawn by: AP & PB	Checked by: AP & PB	OB	Preparation Scale: as shown @ A1
Date: 29-04-2019	Drawing No: WPI P066 NI - 47 MT-PR-FF-J-03.1	Revision: 1.0	

Drawing Not For Construction



Section C-C  
Scale: 1:5 on A1

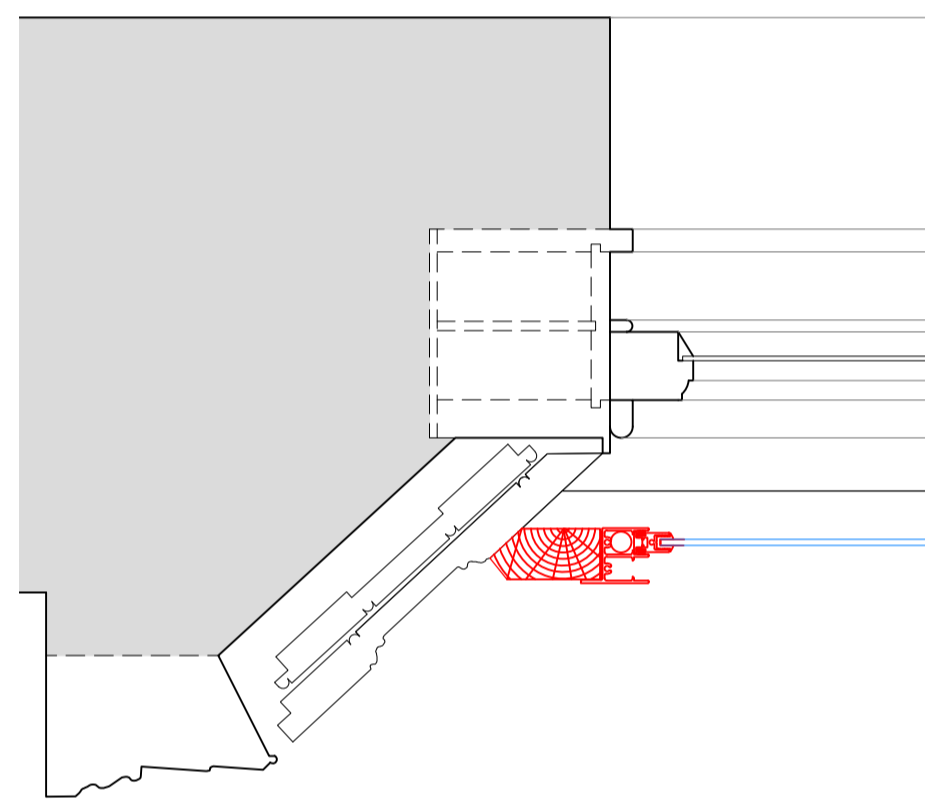

Section D-D  
Scale: 1:5 on A1

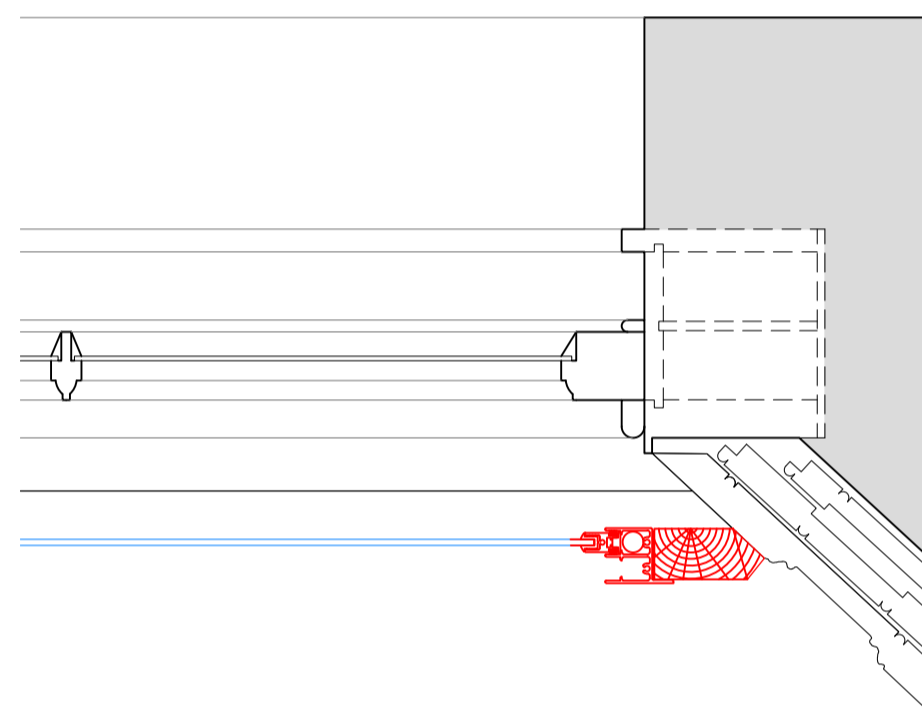

Section E-E  
Scale: 1:5 on A1

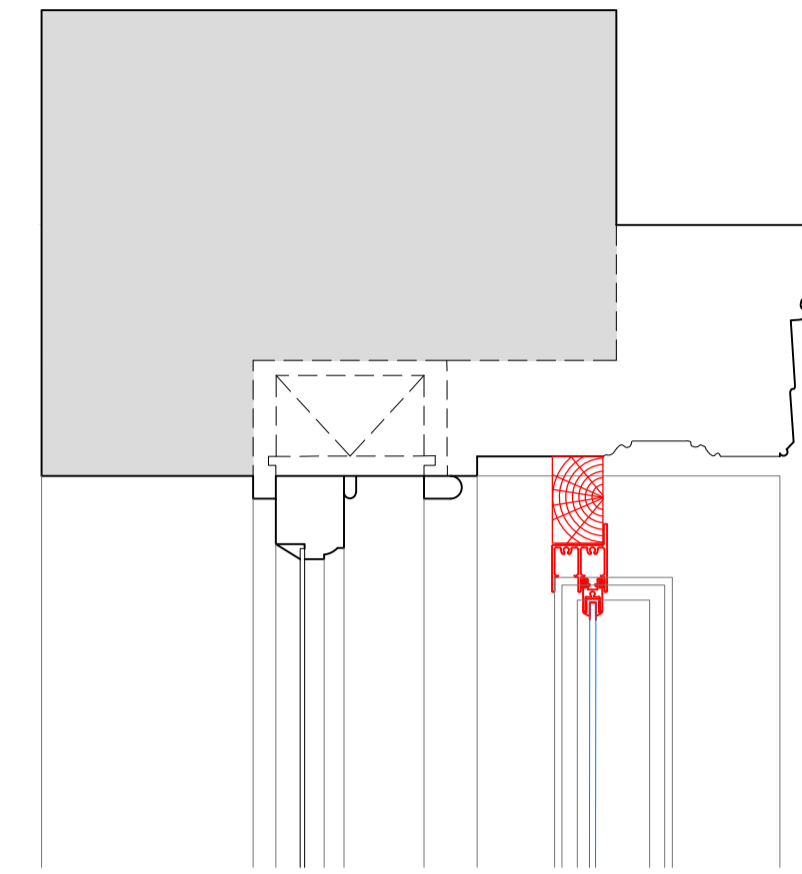

Section F-F  
Scale: 1:5 on A1

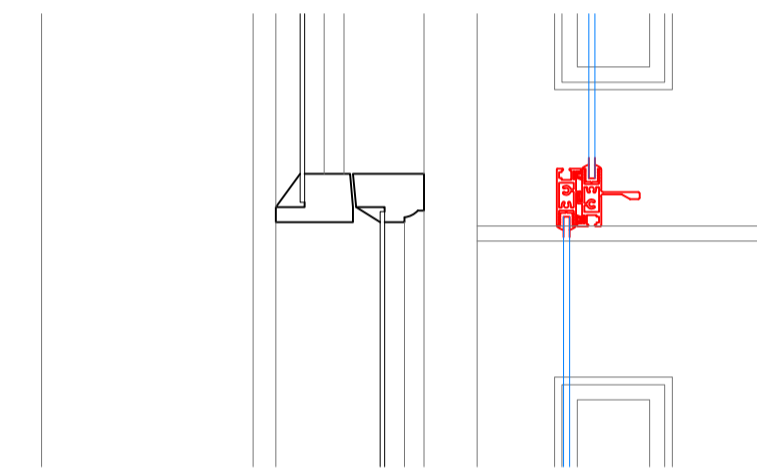

Section G-G  
Scale: 1:5 on A1

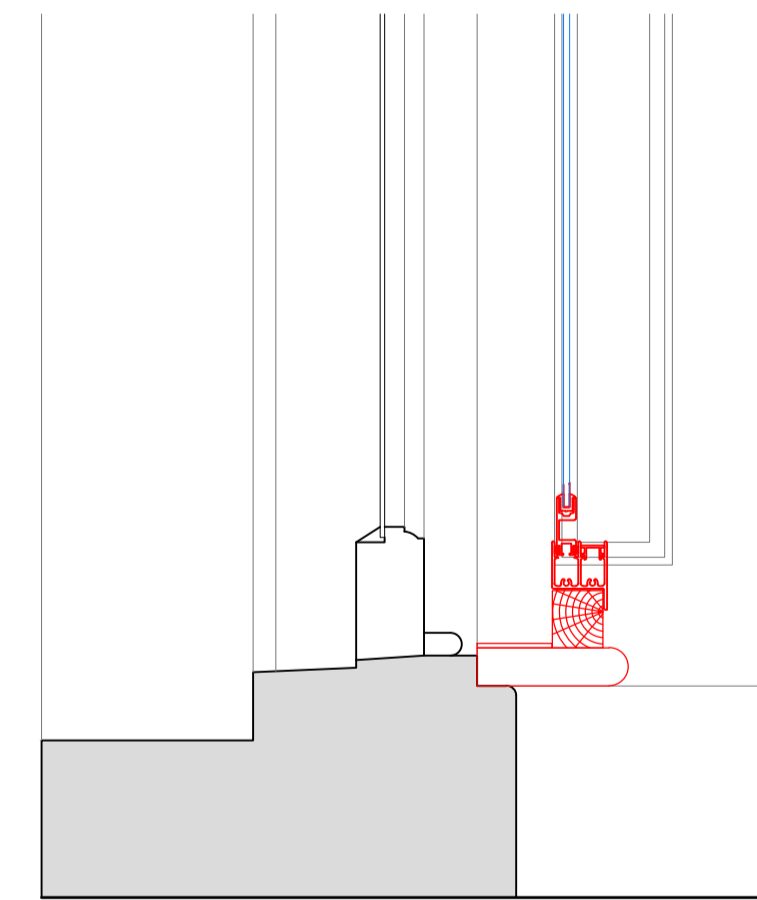

SECONDARY GLAZING SHOWN IN RED FOR VISUAL CLARITY ONLY

Revision	Date	Assessment
1.0	25-01-2021	Issued for listed building consent application

Do not reproduce this drawing without written permission  
All dimensions are in millimetres unless stated otherwise

Drawing Not For Construction

**HS2**

High Speed (HS2) Limited  
1st-3rd Floor  
The Podium  
1 Eversholt Street  
London NW1 2DN

**COSTAIN SKANSKA**

Costain Skanska Joint Venture  
9th Floor  
The Tower  
1 Eversholt Street  
London NW1 2DN

Site Address: 47 Mornington Terrace, London NW1			
Drawing Title: First Floor - Lounge: PROPOSED Secondary Glazing Details - Sheet 3 of 3			
Drawn by: AP & PB	Checked by: AP & PB	Reviewed by: OB	Presentation Scale: 1:5 @ A1
Date: 29-04-2019	Drawing No: WPI P066 NI - 47 MT-PR-FF-J-03.2	Revision: 1.0	

Internal Room Elevation

Scale: 1:10

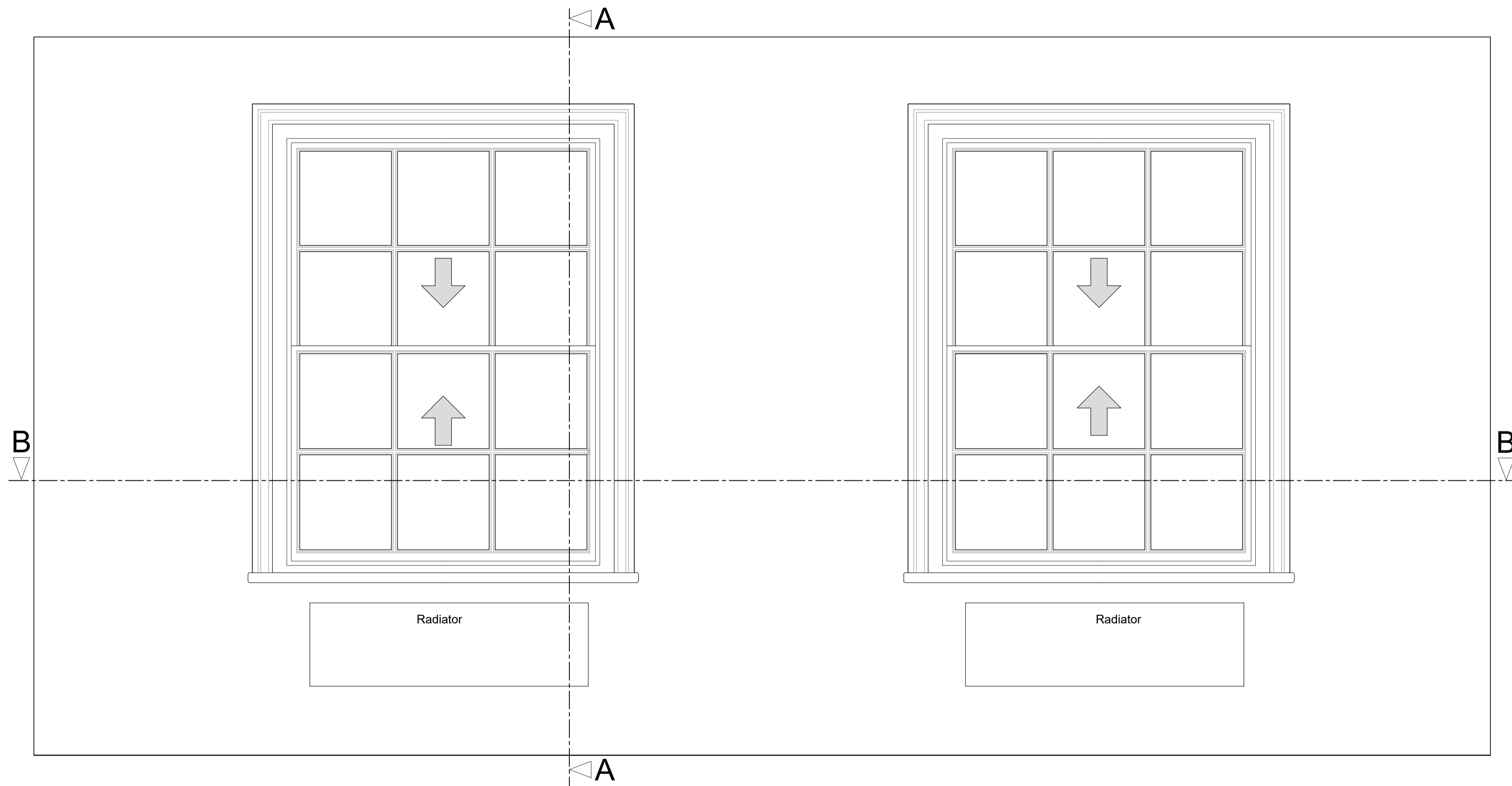

Section A-A through External Wall

Scale: 1:10

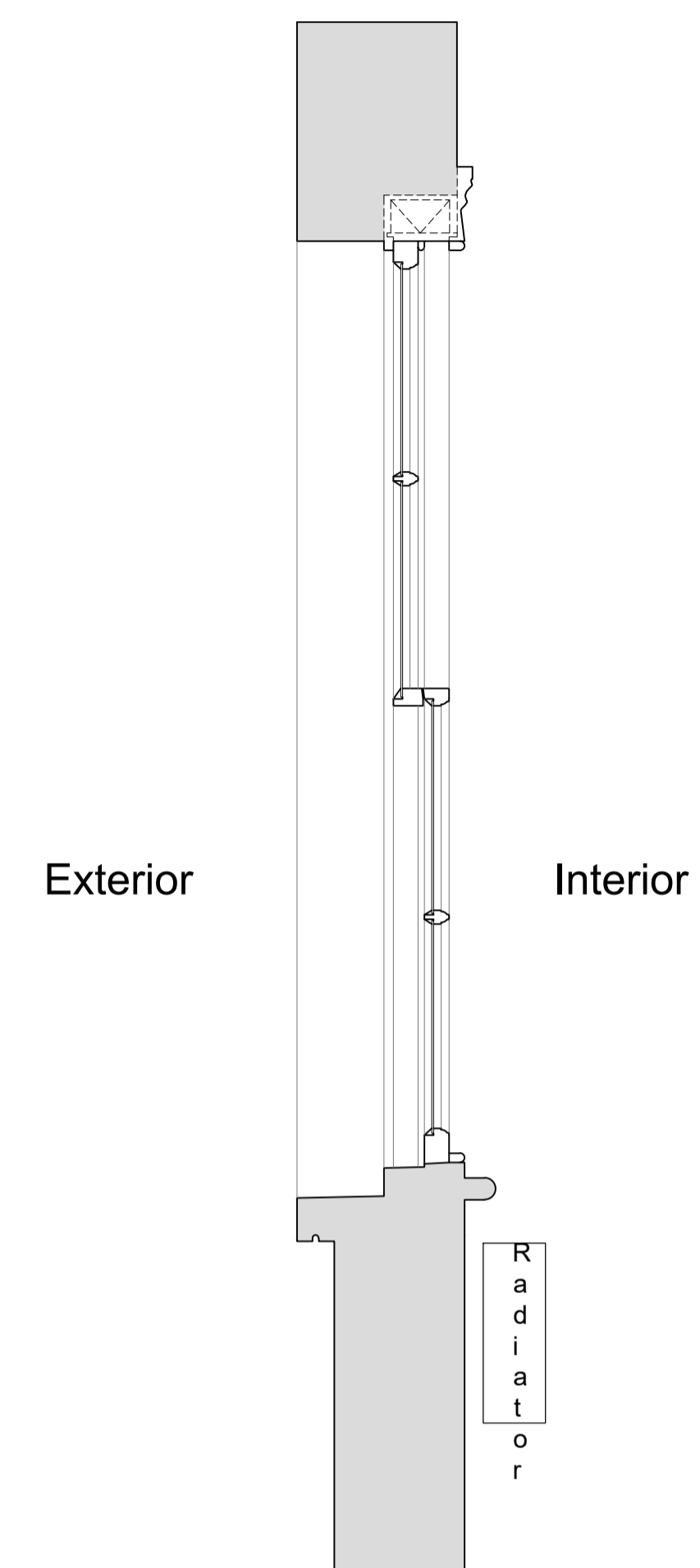

Plan Section B-B

Scale: 1:10

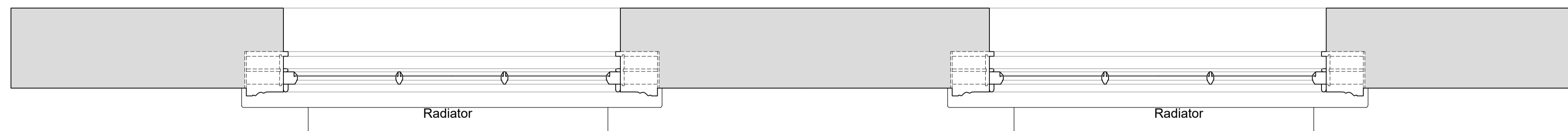

Revision	Date	Assessment
1.0	25-01-2021	Issued for listed building consent application

Do not reproduce this drawing without written permission  
All dimensions are in millimetres unless stated otherwise

**HS2**

High Speed (HS2) Limited  
1st-3rd Floor  
The Podium  
1 Eversholt Street  
London NW1 2DN

**COSTAIN SKANSKA**

Costain Skanska Joint Venture  
9th Floor  
The Tower  
1 Eversholt Street  
London NW1 2DN

Site Address: 47 Mornington Terrace, London NW1			
Drawing Title: Second Floor - Lounge: EXISTING Window Joinery Details - Sheet 1 of 3			
Drawn by: AP & PB	Checked by: AP & PB	Checked by: OB	Presentation Scale: as shown @ A1
Date: 29-04-2019	Drawing No: WPI P066 NI - 47 MT-EX-SF-J-04	Revision: 1.0	

Drawing Not For Construction

Internal Room Elevation with Secondary Glazing Installed

Scale: 1:10

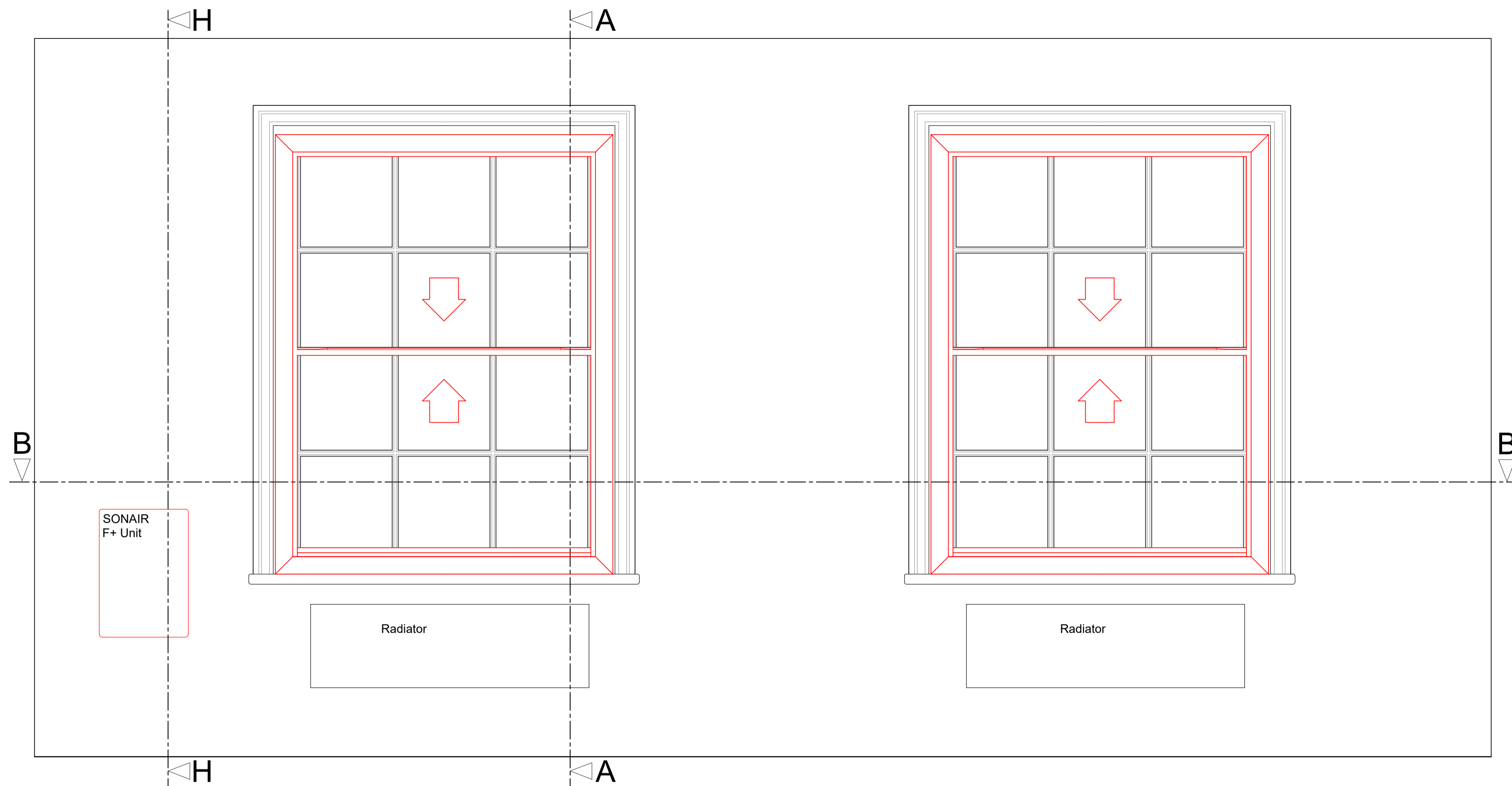

Section A-A through External Wall with Secondary Glazing Installed

Scale: 1:10

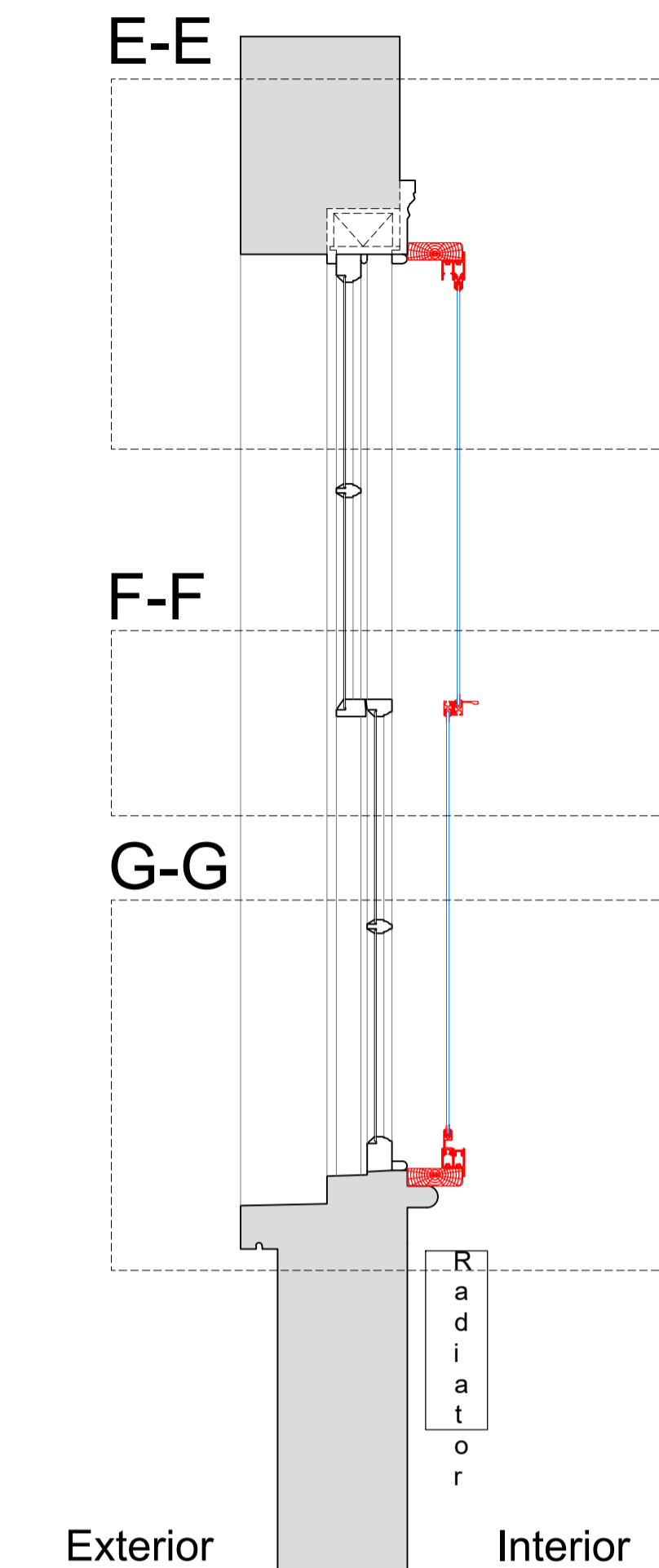

Section H-H through External Wall with Mechanical Ventilation Installed

Scale: 1:10

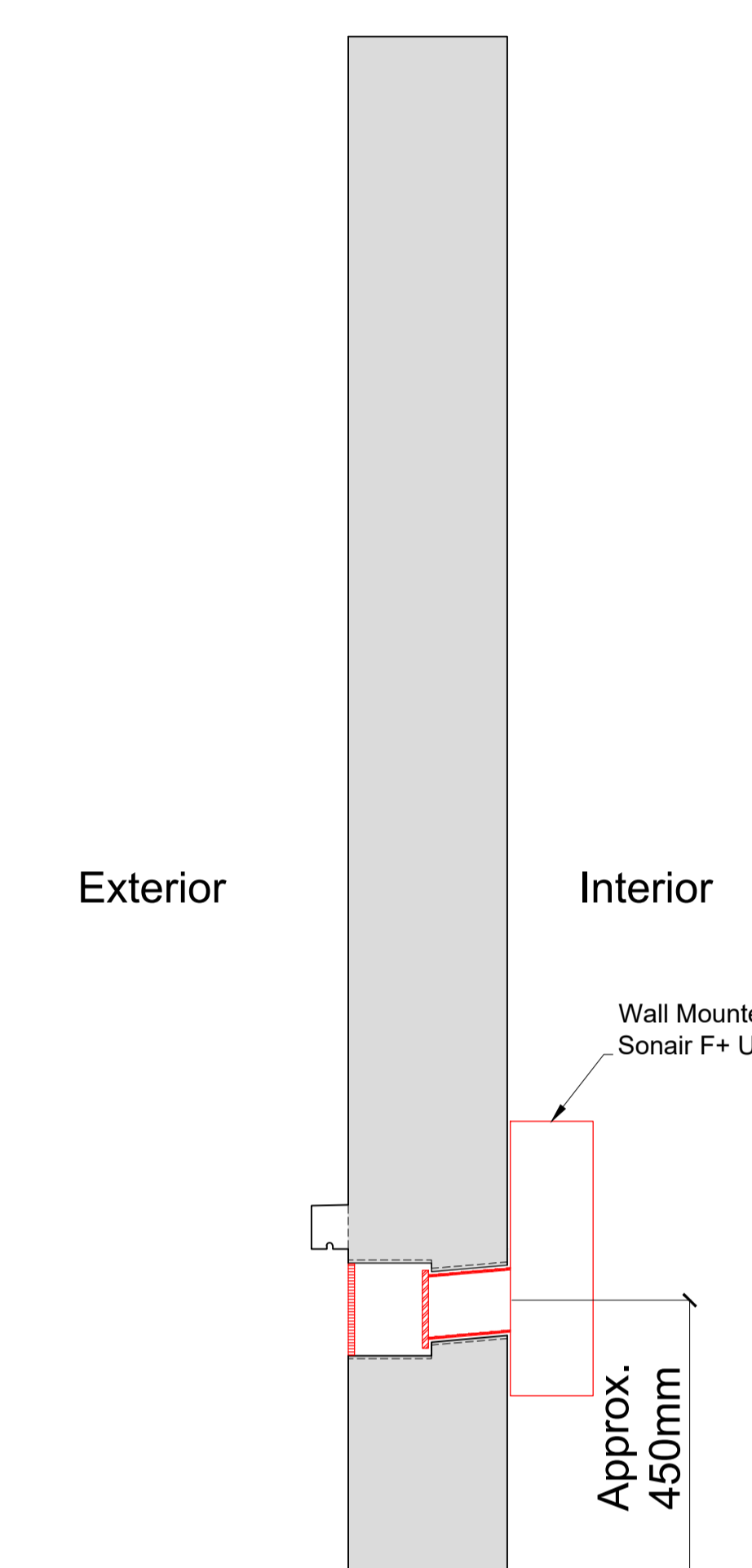

Plan Section B-B with Secondary Glazing Installed

Scale: 1:10

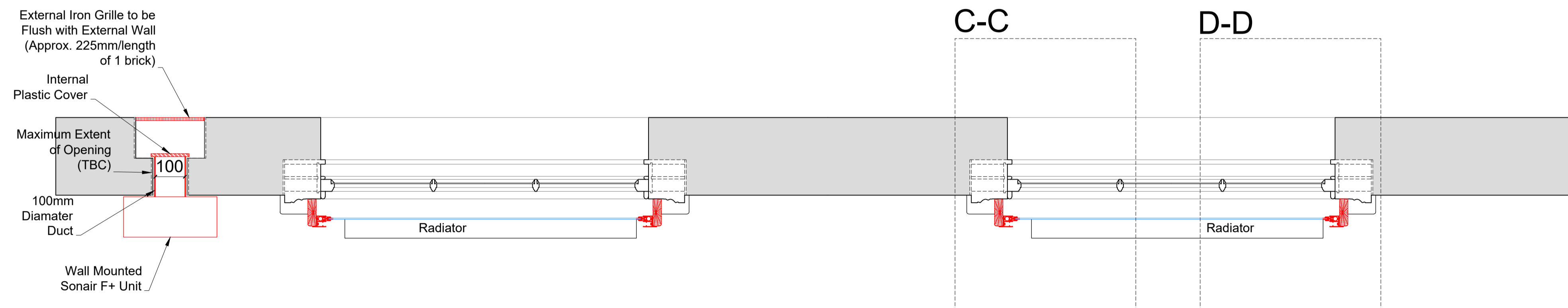

Detail of Sonair Unit

Scale: 1:5

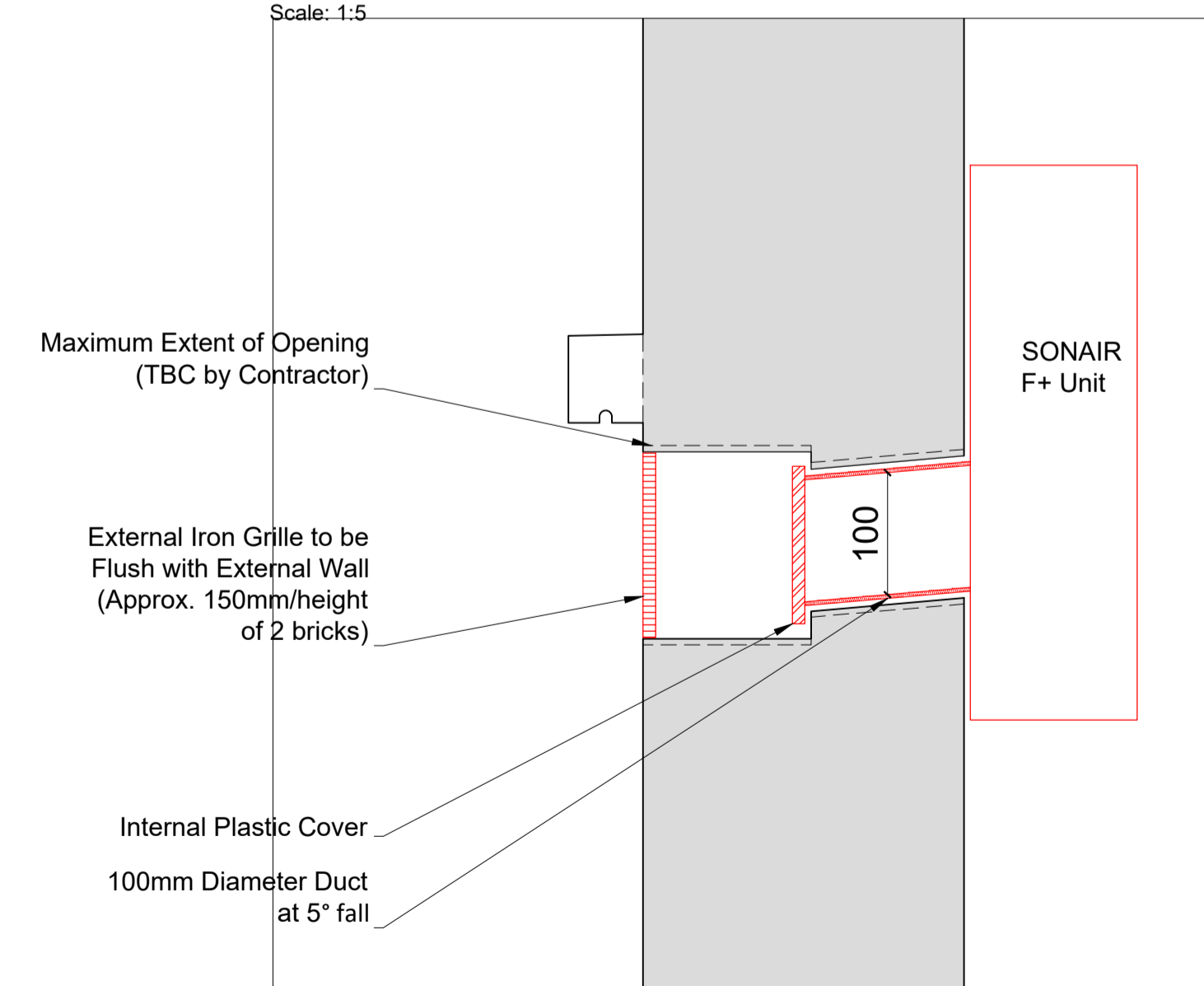

SECONDARY GLAZING SHOWN IN RED FOR VISUAL CLARITY ONLY

Revision	Date	Assessment
1.0	25-01-2021	Issued for listed building consent application

Do not reproduce this drawing without written permission  
All dimensions are in millimetres unless stated otherwise

**HS2**

High Speed (HS2) Limited  
1st-3rd Floor  
The Podium  
1 Eversholt Street  
London NW1 2DN

**COSTAIN SKANSKA**

Costain Skanska Joint Venture  
9th Floor  
The Tower  
1 Eversholt Street  
London NW1 2DN

Site Address:			
47 Morningside Terrace, London NW1			
Drawing Title:			
Second Floor - Lounge: PROPOSED Secondary Glazing Details - Sheet 2 of 3			
Drawn by:		Checked by:	
AP & PB	AP & PB	OB	as shown @ A1
Date:		Revision:	
29-04-2019	WPI P066 NI - 47 MT-PR-SF-J-04.1		1.0

Drawing Not For Construction

Section C-C  
Scale: 1:5 on A1

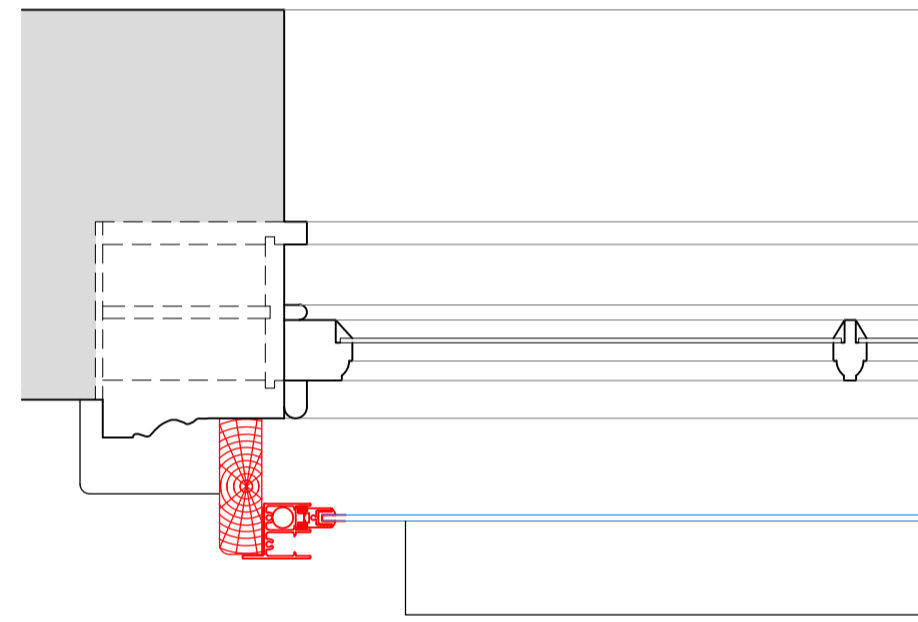

Section D-D  
Scale: 1:5 on A1

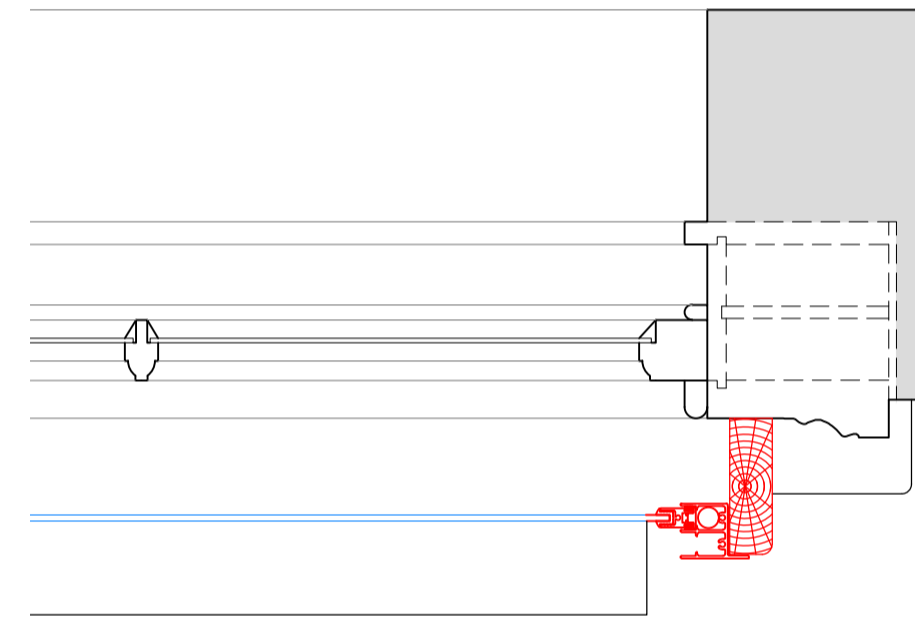

Section E-E  
Scale: 1:5 on A1

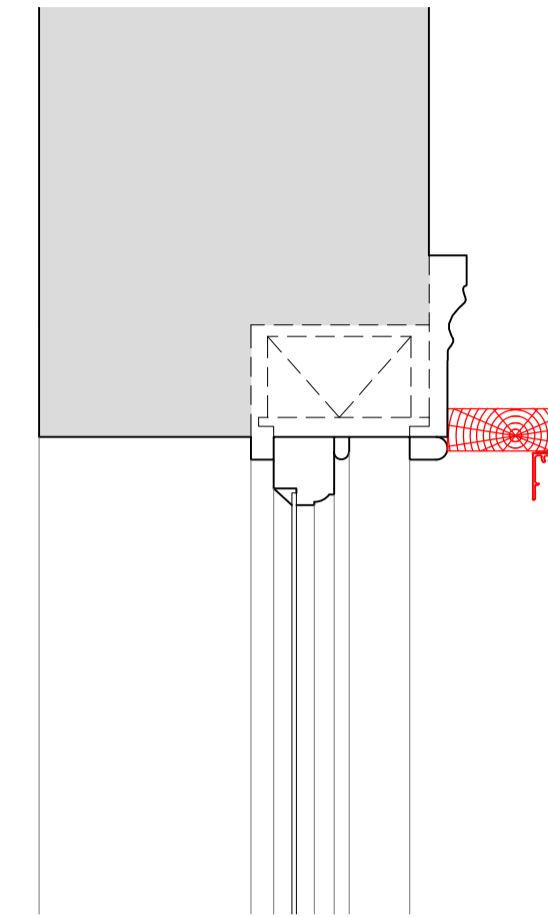

Section F-F  
Scale: 1:5 on A1

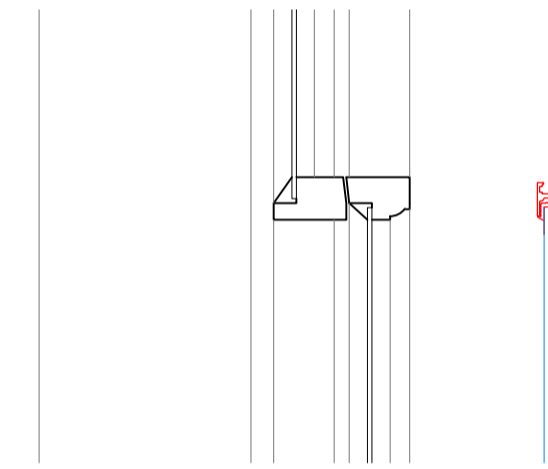

Section G-G  
Scale: 1:5 on A1

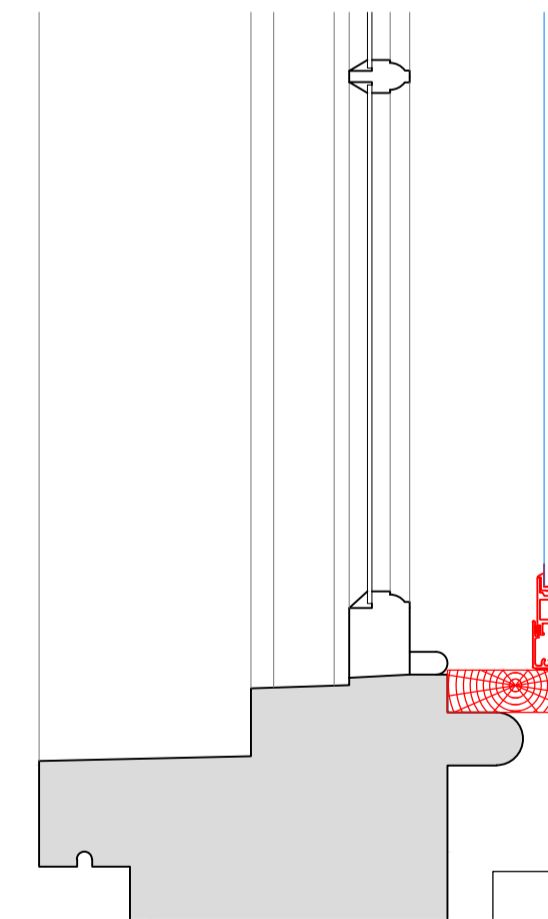

SECONDARY GLAZING SHOWN IN RED FOR VISUAL CLARITY ONLY

Revision	Date	Assessment
1.0	25-01-2021	Issued for listed building consent application

Do not reproduce this drawing without written permission  
All dimensions are in millimetres unless stated otherwise

Drawing Not For Construction

**HS2**

High Speed (HS2) Limited  
1st-3rd Floor  
The Podium  
1 Eversholt Street  
London NW1 2DN

**COSTAIN SKANSKA**

Costain Skanska Joint Venture  
9th Floor  
The Tower  
1 Eversholt Street  
London NW1 2DN

Site Address: 47 Morningside Terrace, London NW1			
Drawing Title: Second Floor - Lounge: PROPOSED Secondary Glazing Details - Sheet 3 of 3			
Drawn by: AP & PB	Checked by: OB	Presented by: OB	Scale: 1:5 @ A1
Date: 29-04-2019	Drawing No: WPI P066 NI - 47 MT-PR-SF-J-04.2	Revision: 1.0	

Internal Room Elevation

Scale: 1:10

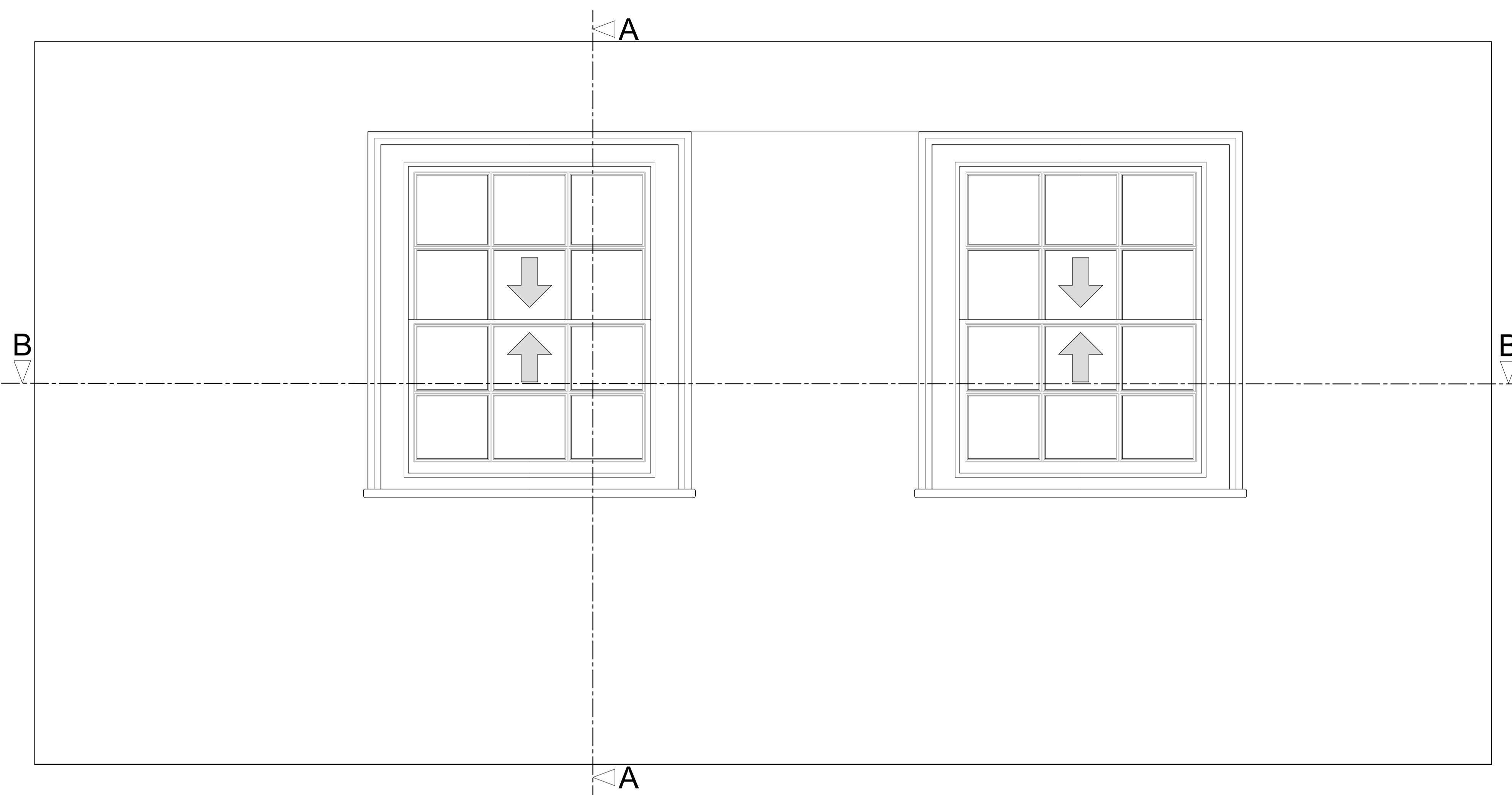

Section A-A through External Wall

Scale: 1:10

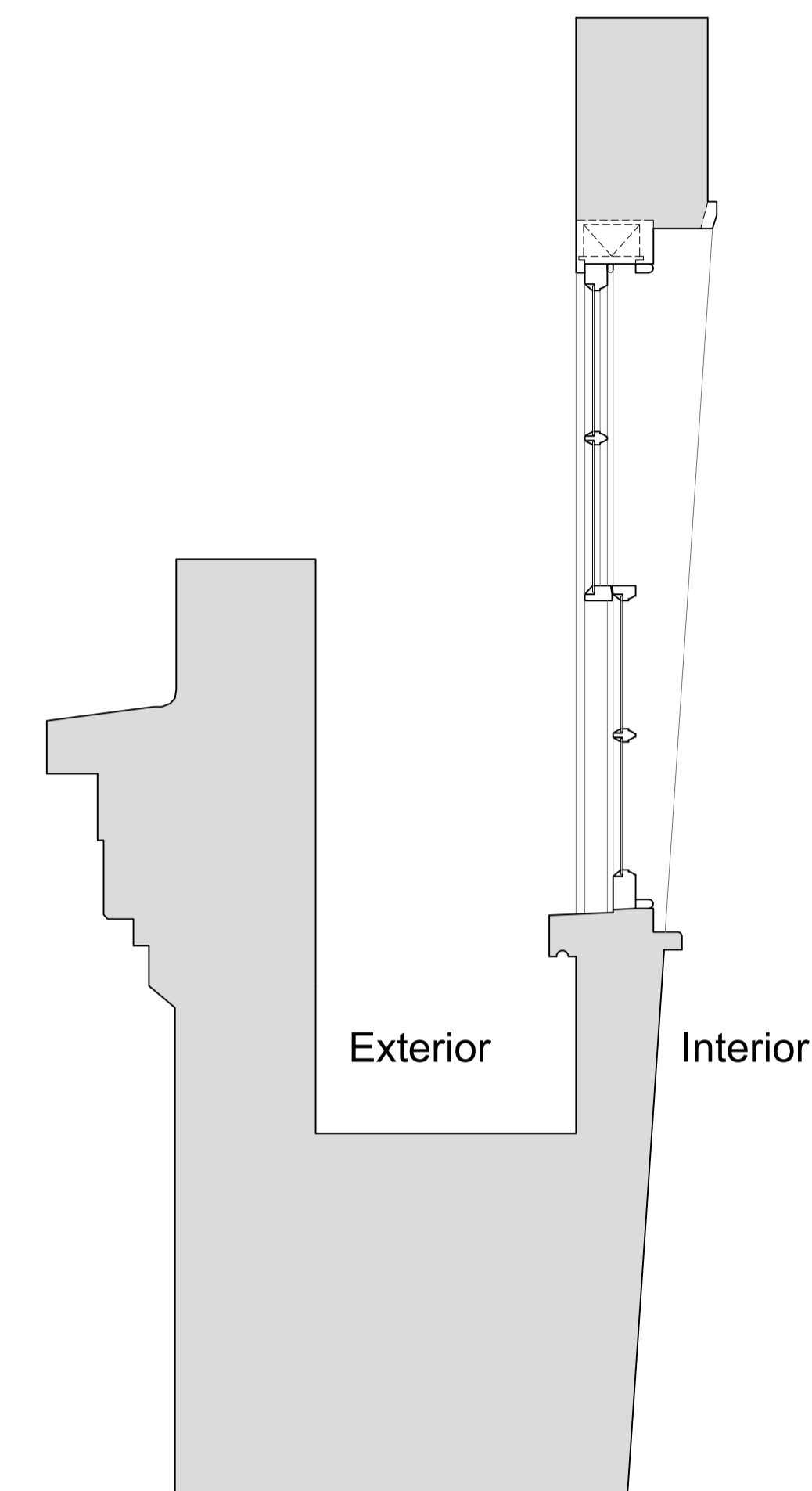

Plan Section B-B

Scale: 1:10

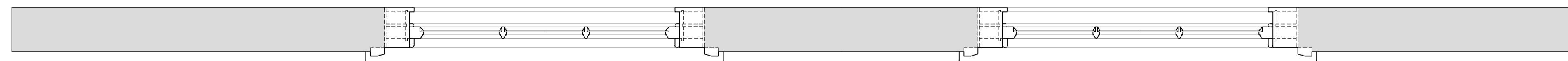

Revision	Date	Assessment
1.0	25-01-2021	Issued for listed building consent application

Do not reproduce this drawing without written permission  
All dimensions are in millimetres unless stated otherwise

**HS2**

High Speed (HS2) Limited  
1st-3rd Floor  
The Podium  
1 Eversholt Street  
London NW1 2DN

**COSTAIN SKANSKA**

Costain Skanska Joint Venture  
9th Floor  
The Tower  
1 Eversholt Street  
London NW1 2DN

Site Address: 47 Morningside Terrace, London NW1			
Drawing Title: Third Floor - Lounge: EXISTING Window Joinery Details - Sheet 1 of 3			
Drawn by: AP & PB	Checked by: AP & PB	Checked by: OB	Presentation Scale: as shown @ A1
Date: 29-04-2019	Drawing No: WPI P066 NI - 47 MT-EX-TF-J-05	Revision: 1.0	

Drawing Not For Construction

Internal Room Elevation with Secondary Glazing Installed

Scale: 1:10

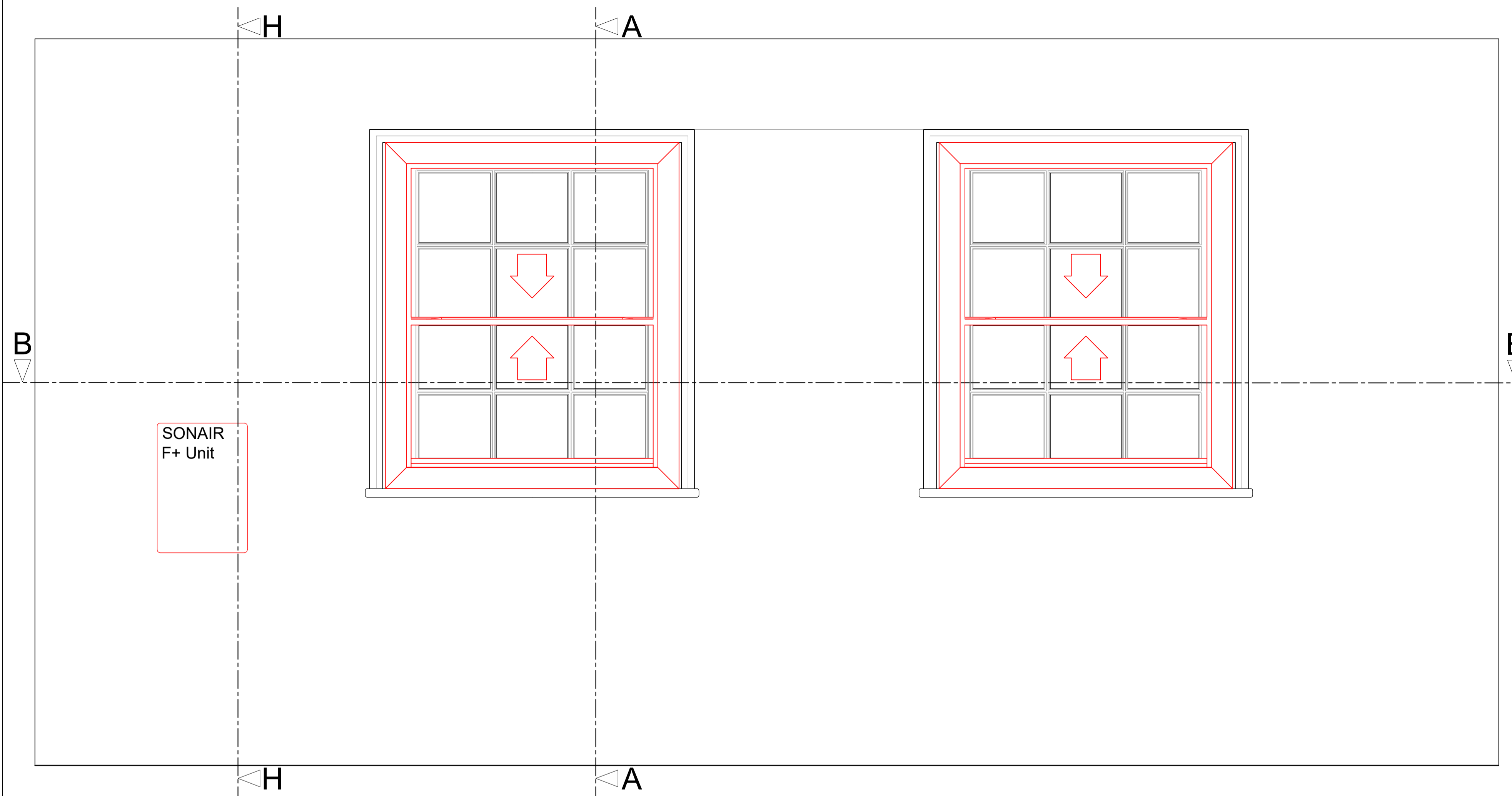

Section A-A through External Wall with Secondary Glazing Installed

Scale: 1:10

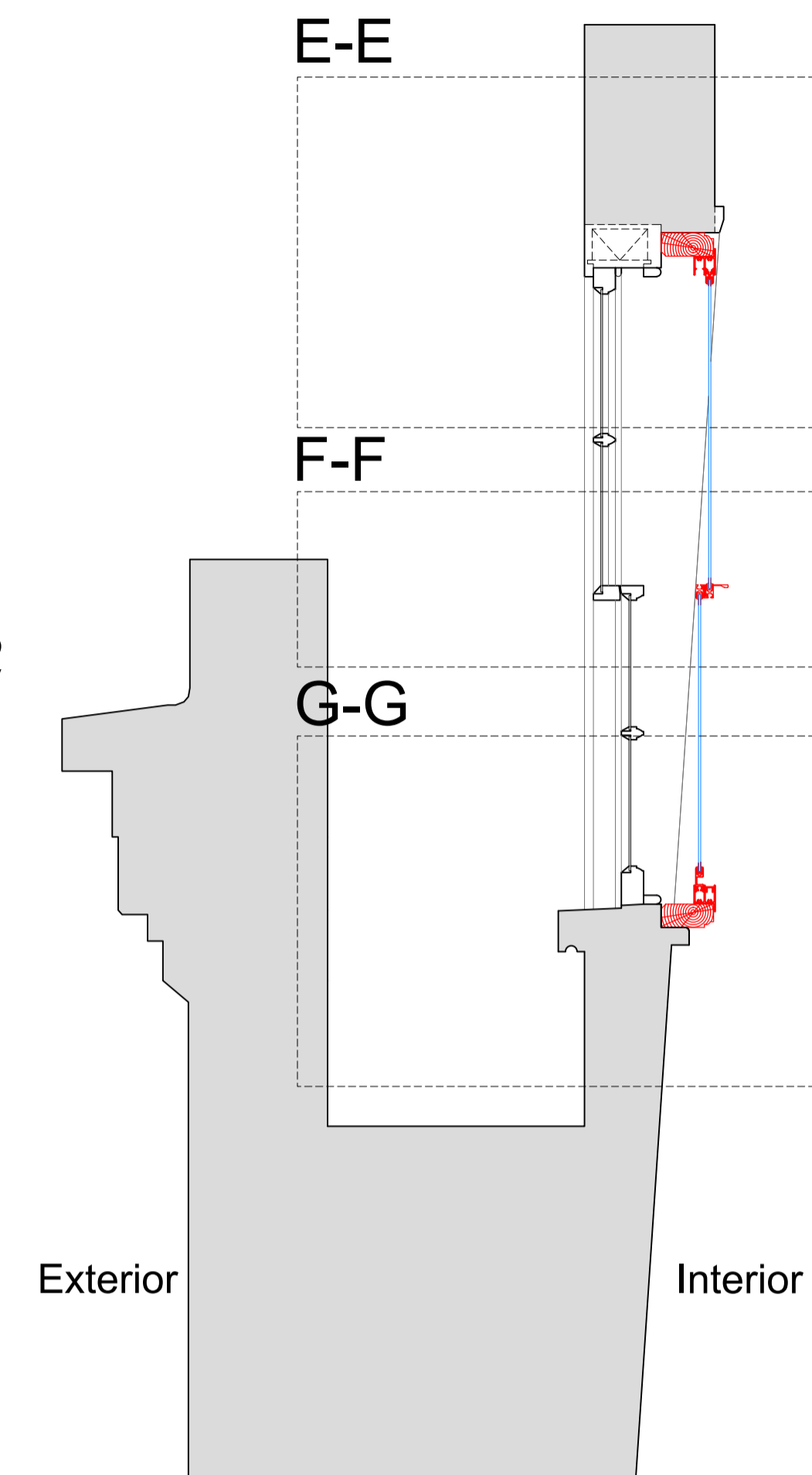

Section H-H through External Wall with Mechanical Ventilation Installed

Scale: 1:10

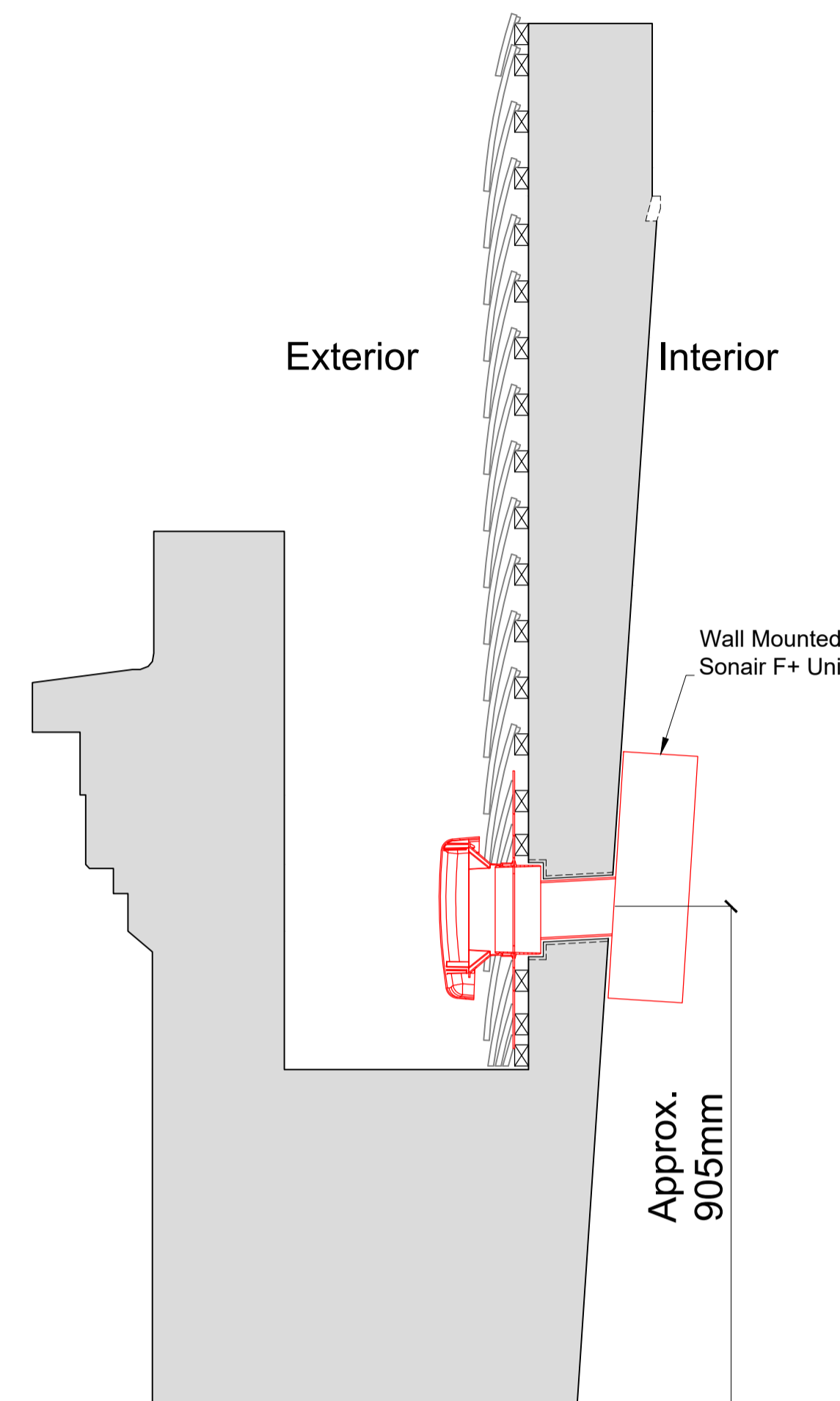

Plan Section B-B with Secondary Glazing Installed

Scale: 1:10

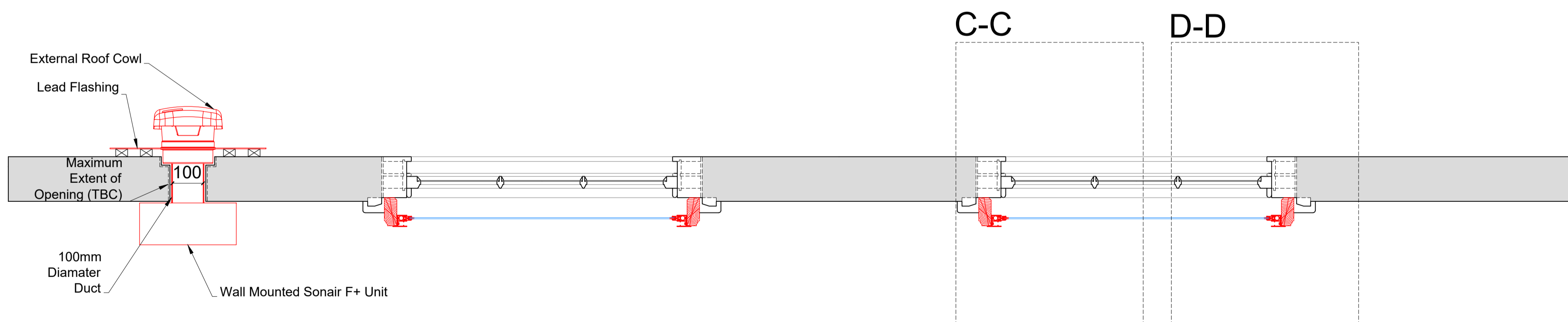

Detail of Sonair Unit

Scale: 1:5

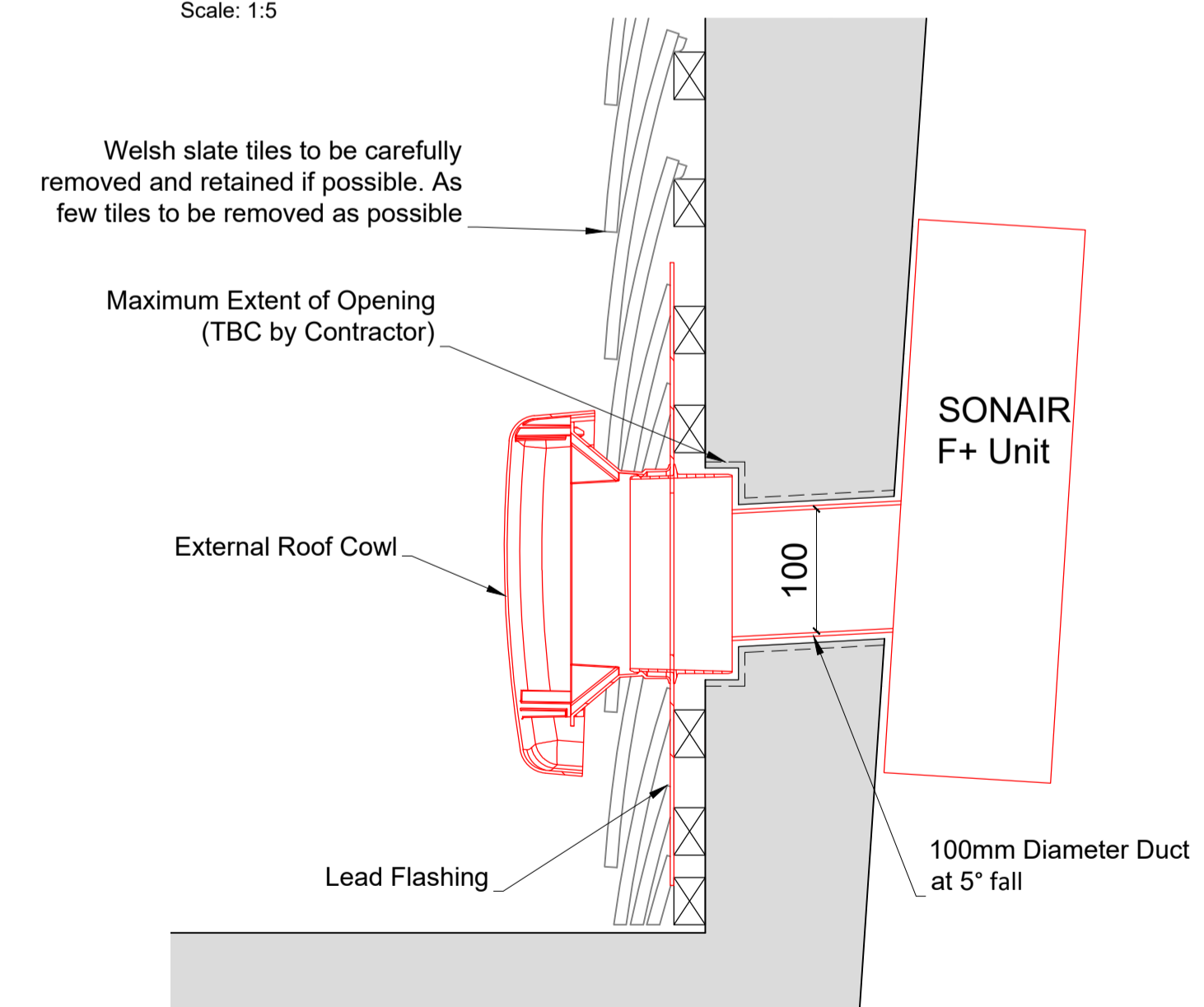

SECONDARY GLAZING SHOWN IN RED FOR VISUAL CLARITY ONLY

Revision	Date	Assessment
1.0	25-01-2021	Issued for listed building consent application

Do not reproduce this drawing without written permission  
All dimensions are in millimetres unless stated otherwise

**HS2**

High Speed (HS2) Limited  
1st-3rd Floor  
The Podium  
1 Eversholt Street  
London NW1 2DN

**COSTAIN SKANSKA**

Costain Skanska Joint Venture  
9th Floor  
The Tower  
1 Eversholt Street  
London NW1 2DN

Site Address: 47 Morningside Terrace, London NW1			
Drawing Title: Third Floor - Lounge: PROPOSED Secondary Glazing Details - Sheet 2 of 3			
Drawn by: AP & PB	Checked by: OB	Presented by: as shown @ A1	
Date: 29-04-2019	Drawing No: WPI P066 NI - 47 MT-PR-TF-J-05.1	Revision: 1.0	

Drawing Not For Construction

Section C-C  
Scale: 1:5 on A1

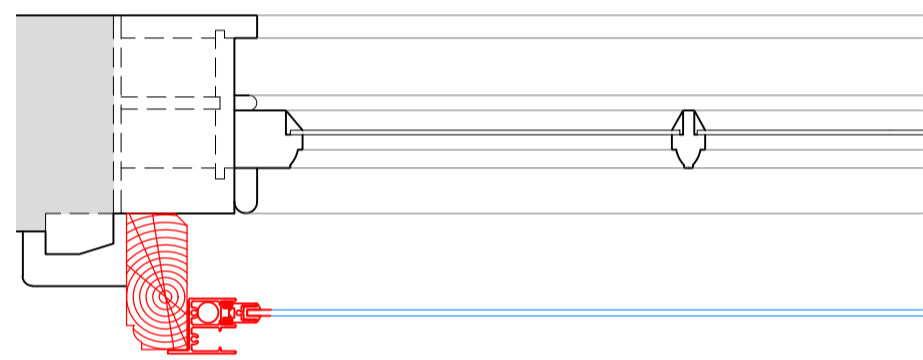

Section D-D  
Scale: 1:5 on A1

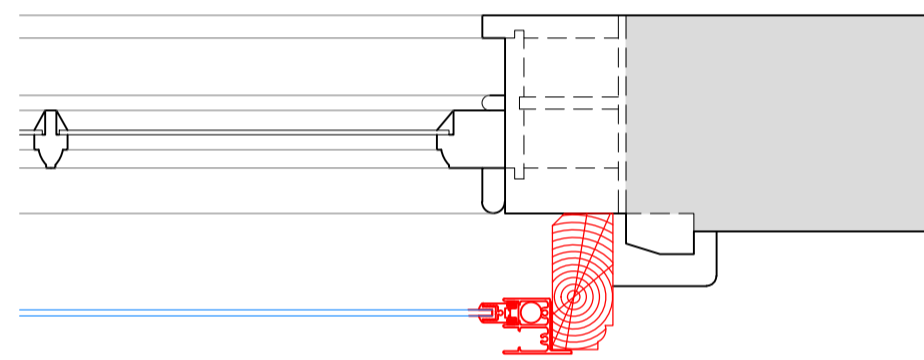

Section E-E  
Scale: 1:5 on A1

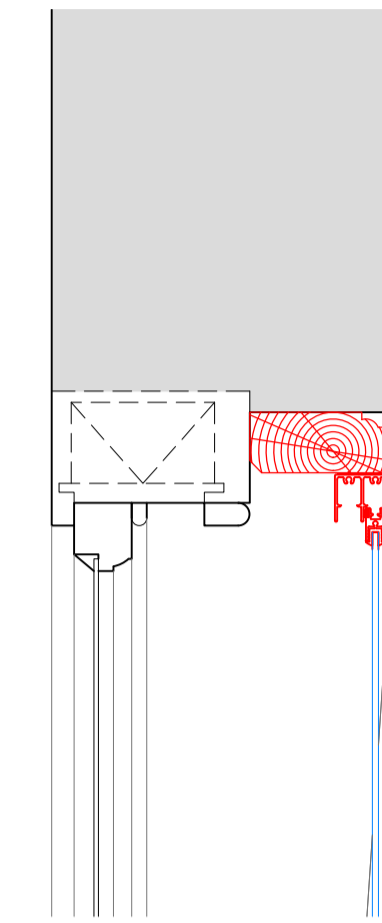

Section F-F  
Scale: 1:5 on A1

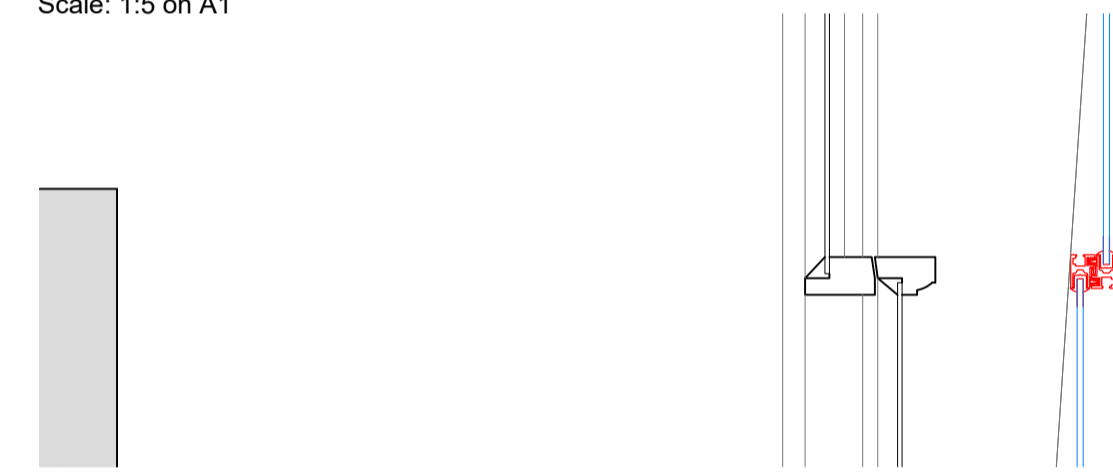

Section G-G  
Scale: 1:5 on A1

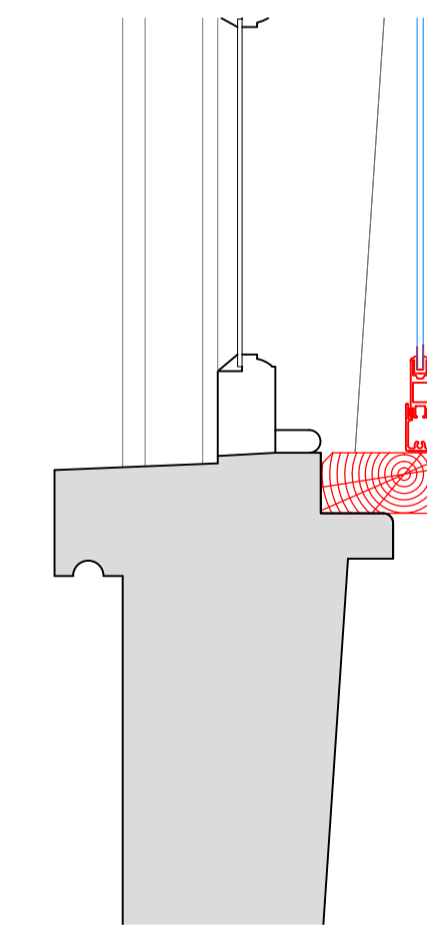

SECONDARY GLAZING SHOWN IN RED FOR VISUAL CLARITY ONLY

Revision	Date	Assessment
1.0	25-01-2021	Issued for listed building consent application

Do not reproduce this drawing without written permission  
All dimensions are in millimetres unless stated otherwise

**HS2**

High Speed (HS2) Limited  
1st-3rd Floor  
The Podium  
1 Eversholt Street  
London NW1 2DN

**COSTAIN SKANSKA**

Costain Skanska Joint Venture  
9th Floor  
The Tower  
1 Eversholt Street  
London NW1 2DN

Site Address: 47 Morningside Terrace, London NW1			
Drawing Title: Third Floor - Lounge: PROPOSED Secondary Glazing Details - Sheet 3 of 3			
Drawn by: AP & PB	Checked by: AP & PB	Reviewed by: OB	Presentation Scale: 1:5 @ A1
Date: 29-04-2019	Drawing No: WPI P066 NI - 47 MT-PR-TF-J-05.2		Revision: 1.0

Drawing Not For Construction