

**THERMAL™**

**5-35Hi+**

High Insulation (Hi+)  
Window and Door Systems





# THERMAL™

To comply with the latest building regulations Metal Technology has developed a range of high performance window and door systems. Using the latest technology, the company has developed bespoke thermal gaskets, cellular foams and polyamide thermal isolators which will allow architects and designers to achieve low U values.

## 50mm Frame Systems

**4-20Hi+**

Casement



**5-20D Hi+**

Door



**5-20Hi+**

Tilt and Turn  
Tilt and Slide



**7-20Hi+**

Pivot



## 75mm Frame Systems (Available in Hi and Hi+ Formats)

**4-35Hi+**

Casement



**5-35Hi+**

Tilt and Turn  
Tilt and Slide



## Technical Support

Metal Technology offers a comprehensive design and specification service to architects, developers and main contractors through its team of dedicated architectural advisors. Tailored specifications are provided in NBS format and are also available online along with CAD details and full test data. Thermal modelling and free air flow software allows accurate information to be analysed at early design stage assisting with WER (window energy ratings) and Bream assessments.

# High performance systems offering bespoke solutions and total design flexibility.



### Nationwide Fabricator Coverage

Metal Technology has an approved network of fabricators throughout the UK and Ireland to ensure geographical continuity and capacity, with companies specialising in all market sectors.



### Market Sectors

Metal Technology products are designed for a diverse range of buildings within the construction market. Key sectors include: Commercial, Retail, Education, Health, Residential/Housing, Hotel/Leisure.



**THERMAL™**

**5-35Hi+**

Metal Technology's System 5-35Hi+ offers the designer a wide and diverse range of profiles that will provide structural integrity, weather performance, thermal enhancement and security. The high performance 5-35Hi+ glazing system complies with the following standards: BS 6375 pt 1, 2 and 3, PAS 24 and is acoustically tested in accordance with BS EN ISO 140-3 and BS EN ISO 717-1.



**Independently Weather Performance Tested to BS 6375-1**

Air Infiltration BS EN 1026	<b>Class 4</b>
Watertightness BS EN 1027	<b>Class E900</b>
Wind Resistance BS EN : 12211	<b>Class E2400</b>





**THERMAL™**

**Thermal Performance**

Metal Technology's **THERMAL** range, in conjunction with the correct glass specification, is designed to aid compliance with the latest thermal requirements of the current building regulations. The extended polyamide thermal break profiles, incorporating integral fins have been specifically designed to minimise heat transfer across the window profiles. This innovative and advanced thermal break technology provides the basis of the 5-35Hi system.

The 5-35Hi+ System further boosts thermal performance through the introduction of specially designed thermal gaskets and foam profiles. These reduce radiation heat loss across the air cavities within the window profiles to provide additional thermal enhancement. The 5-35Hi and 5-35Hi+ systems offer significantly improved U-frame values over more traditional thermally broken aluminium window systems.

	U-frame values	
	5-35Hi	5-35Hi+
Fixed light outer frame	<b>1.92 W/m²K</b>	<b>1.34 W/m²K</b>
Outer frame and tilt turn vent	<b>2.30 W/m²K</b>	<b>1.63 W/m²K</b>

The following table, based on a standard commercial GGF window configuration and warm edge spacers, demonstrates how such improved U-frame values then contribute to improving the overall thermal performance of a complete window.

Achievable whole window U-value	Centre pane U-value	
	5-35Hi	5-35Hi+
5-35Hi tilt turn vent	<b>1.49 W/m²K</b>	<b>1.10 W/m²K</b>
5-35Hi+ tilt turn vent	<b>1.33 W/m²K</b>	<b>0.94 W/m²K</b>

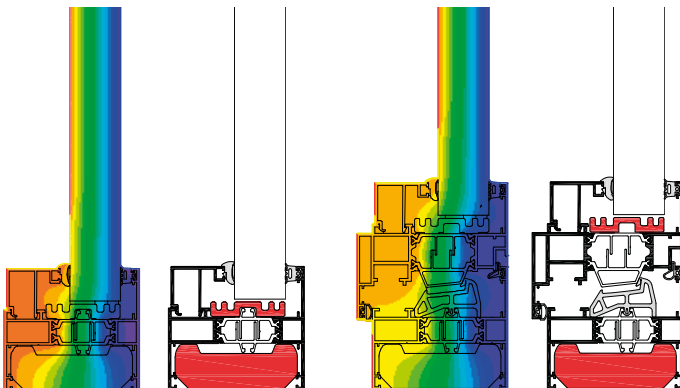

Metal Technology can provide tailored U-value calculations using their dedicated estimating software to calculate overall project average window U-values for their full range of systems.

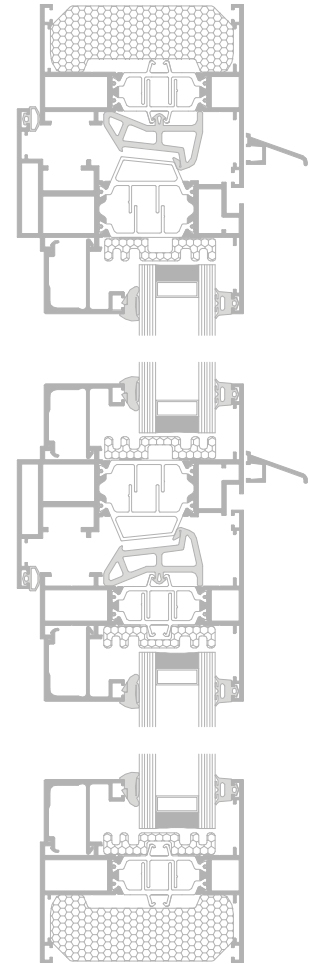

**Breem Sustainability Rating**

When assessed in accordance with the profile mass formula, as set out in the BRE's Green Guide for sustainable design and environmental performance, Metal Technology's 5-35Hi and 5-35Hi+ Systems achieved an **'A' rating**.

**Window Energy Rating**

Metal Technology's 5-35Hi and 5-35Hi+ Systems has been assessed by an approved simulator in accordance with the BFC's guidelines, using their official Window Energy Rating software, and has been proven to be capable of achieving an **'A+' rating**.

WER Rating Scale	Window Rating
• A+ •	<b>A+</b>
A	
B	
C	
D	
E	
F	
G	



## Specification Overview

### Introduction

The Metal Technology 5-35Hi+ polyamide tilt and turn window suite has been developed with a diverse range of profile options. Bespoke thermal isolators and insulation combined with structural mullions, vents and outer frames offer architects and designers the ability to achieve flexible design solutions.

### Scope

This specification defines materials, construction, finishes and size limits for the Tilt and Turn Window.

### Materials

Aluminium profiles are extruded from aluminium alloy 6060T6, T5 or T4 complying with the recommendations of BS EN 12020-2 / BS EN 755-Parts 1 to 9. Polyamide thermal breaks are produced from glass reinforced nylon sections designed to withstand temperatures in excess of 200°C, allowing the sections to be powder coated after thermally breaking.

### Construction

Frame members are mitre cut at 45°, corners are reinforced with extruded aluminium crimping cleats and corner braces, and a secure joint is formed by pneumatically crimping into the extruded crimping cleat. Mullion and transom bars are square cut shaped and fixed securely to the frame by means of stainless steel screws and fixing cleat joints. All frame joints are sealed during construction against entry of water using Metal Technology's two-part adhesive. Metal Technology recommend that only A2 or A4 Austenitic (300 series/class 70) stainless steel fixing screws are used in the assembly of their products.

### Finishes

The range of sections can be provided in either of the following range of finishes: Anodised to BS EN 12373-1 or BS 3987. Powder organic coated to BS 6496 or BS EN 12206-1. The System 5-35Hi+ window can accommodate a different colour/finish internally to that used externally if required.

### Glazing

This system offers internally glazed sashes and can accommodate glazing units from 28mm to 47mm units. Fixed panes may be externally glazed with the addition of a liner bar profile.

### Security

System 5-35Hi+ has passed PAS 24 "Specification for Enhanced Security Performance" as generally accepted on Secure by Design projects. To conform, the window hardware must be in accordance with the tested sample as detailed in Metal Technology's technical literature. Security products should be labelled by the fabricator in accordance with BS 4873.

### Installation

Detailed installation instructions are provided in Metal Technology's technical literature which should be strictly followed.

### Max Size Limitation

	Vent Width	Vent Height
Tilt Before Turn	1500mm	2500mm
Tilt Only Sashes	2400mm	2000mm
Turn Only Sashes	1500mm	2400mm

Maximum height and maximum width cannot be achieved simultaneously. This table provides basic guidance. Please refer to size limitation charts in Metal Technology's technical literature for further details.

### Open In Window Fittings

The 5-35Hi+ sections are designed to suit tilt before turn fittings, turn only fittings (side hung) and tilt only fittings (bottom hung), all come with a variety of handle options. See the relevant section of Metal Technology technical literature for details of ironmongery hardware options for specific window sizes. Metal Technology should be contacted for any special operating requirements.



Metal Technology has a clear commitment to sustainable products that can offer the best available carbon footprint and Global Warming Potential (GWP) for each particular product. Embodied energy (energy to produce, transport and manufacture) and environmental impact are also considered as part of the procurement package.



# Our commitment to sustainable products

## Recycling and Waste Reduction

Where we can influence the design and use of our products in developments, we will base decisions on a sustainable basis where the health and safety of the occupants can be combined with the conserving of resources for future generations. As an industry we are using resources more efficiently with the minimum of energy consumption, to deliver a project that is flexible, durable, has longevity, and where practical, using fixtures and fittings that can be reused.

## Meeting Standards - ISO 14001

ISO 14001 is an international quality system for environmental management, providing a framework to allow businesses to minimise the impact of their operations on the environment. It seeks to establish a company policy for planning environmental objectives and for complying with laws, directives and regulations.

## Aluminium

The intrinsic qualities of aluminium, its infinite recyclability, strength and lightness, durability and low maintenance qualities mean it is one of the most sustainable building materials to be used.

Aluminium is the earth's third most abundant element after oxygen and silicon (ahead of iron).

Aluminium does not emit dust, vapour or particles and is not toxic to touch.

Given its durability and resistance due to applied surface treatments such as anodising or powder coating, aluminium structures need only regular cleaning with neutral detergents followed by rinsing with water.

Aluminium is non-flammable and, when it reaches its melting point in the event of a fire (about 650°C), it gives off no flammable gases or vapours.

## Life Cycles

Recycling is a valuable asset in the battle against the greenhouse effect. The global aluminium industry has made great strides during the last century to reduce its environmental impact at all stages of the supply chain. Aluminium extraction and refining companies have reduced their energy requirements by almost 70% since 1900.

This has seen the growing use of hydro-electric energy coupled with a vast increase in aluminium that is recycled. At present more than a third of global aluminium production is from recycled metal, a figure that is growing. Recycled aluminium takes just 5% of the energy needed to produce primary metal with a consequent reduction of 95% in the greenhouse gases produced. The recycling process is economically attractive and viable. Recycled aluminium meets almost 40% of the demand for the metal in Europe. Approximately 70% of the material used to produce Metal Technology extrusions is recycled.

Aluminium is infinitely recyclable with no loss of its properties: The aluminium cycle is a closed life cycle.

The Delft University of Technology in the Netherlands has investigated the collection rate of aluminium in buildings. Demolition case studies in six different European countries (France, Germany, Italy, Spain, the Netherlands and the United Kingdom) were carried out and the data gathered shows that collection rates are over 95%.

## Our products are 100% recyclable



High Insulation (Hi+)  
Window and Door Systems



**Metal Technology Limited**  
Steeple Road Industrial Estate  
Steeple Road | Antrim  
Northern Ireland | BT41 1AB

Telephone +44 (0)28 9448 7777  
sales@metaltechnology.com  
metaltechnology.com

This document has been printed on 100% recycled paper.



Metal Technology Headquarters

